



Countries:	CANADA, UNITED STATES, MEXICO	Document ID:	IK1200938
Availability:	ISIS, Bus ISIS, FleetISIS, Body Builder	Revision:	1
Major System:	ENGINES	Created:	8/2/2013
Current Language:	English	Last Modified:	8/9/2013
Other Languages:	NONE	Author:	Caleb Iverson
Viewed:	561		

[Less Info](#)

Hide Details

Coding Information

Copy Link 	Copy Relative Link 	Bookmark View My Bookmarks	Add to Favorites 	Print 	Provide Feedback 	Helpful 7	Not Helpful 1
----------------------	-------------------------------	--	-----------------------------	------------------	-----------------------------	-------------------------	-----------------------------

Title: Replacement Procedure for High-Pressure Turbocharger Center Section on 2010 / 2013 Emissions MaxxFace DT, 9, 10 Engines

Applies To: 2010 / 2013 Emissions MaxxFace DT, 9, 10 Engines

DESCRIPTION

This procedure provides instructions for replacing the High-Pressure (HP) turbocharger center section (cartridge).

PARTS INFORMATION

Part #	Description	Qty.
1889486C92	High Pressure Turbocharger Assembly	1
1881990C1	Pipe Seal/ Crossover Tube Seal (ISC not equipped, If needed)	1
1858048C2	ISC Outlet O-Ring (ISC equipped, If needed)	1

NOTE: If the center section is not available due to part stocking or supply issues, use a COMPLETE turbocharger assembly and simply use the new center section from the kit.

Return the old center section and the NEW turbine housing together in the box. The turbine housing is NOT to be used.

REPAIR PROCEDURE

REMOVAL

1. Bring truck into shop and park on flat surface with wheels turned fully to the right.
2. Shift transmission to Park or Neutral, set parking brake, and install wheel chocks.
3. Unlatch and open hood.
4. Open battery box and disconnect negative battery cable.

NOTE: Draining of the cooling system and removal of the oil soot centrifuge is not required to perform this procedure.

5. Remove four bolts, washers, and right side inner fender.

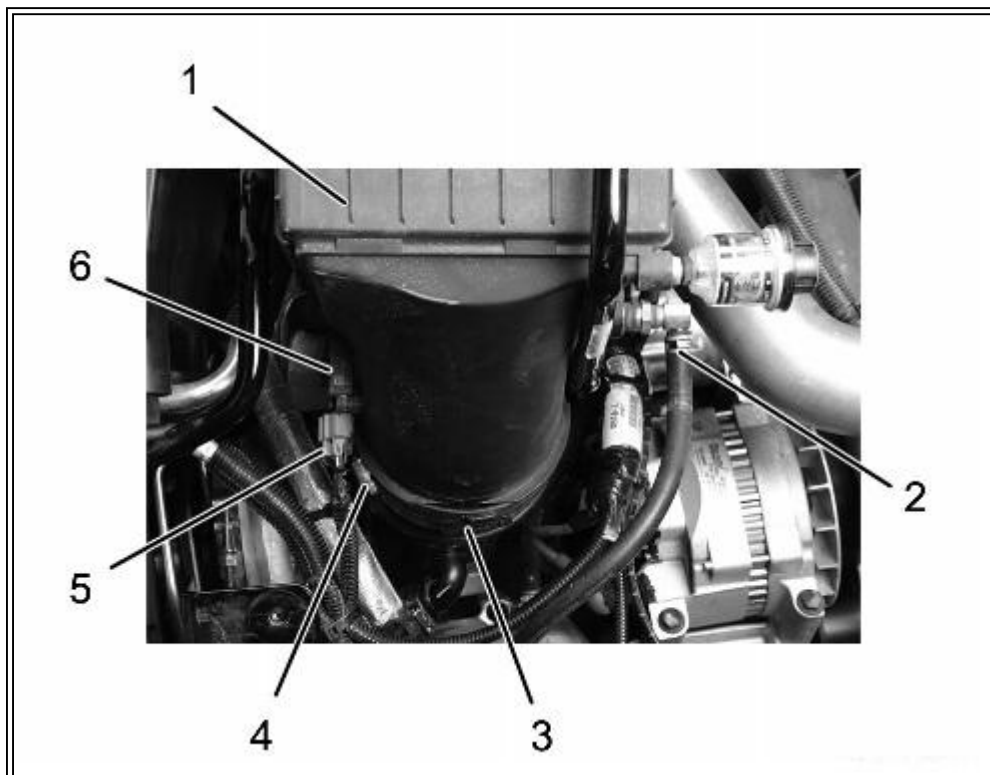

Figure 1. MAF Sensor and Air Compressor Inlet Hose.

1. Air box
2. Air compressor inlet hose

- 3. LP turbocharger inlet elbow duct
- 4. LP turbocharger inlet elbow duct clamp
- 5. MAF sensor connector
- 6. MAF sensor

6. Disconnect MAF sensor connector (Figure 1, Item 5) from MAF sensor (Figure 1, Item 6).

7. Disconnect air compressor inlet hose (Figure 1, Item 2) from air box (Figure 1, Item 1).

8. Loosen air box to LP turbocharger inlet elbow duct clamp (Figure 2, Item 4) and remove LP turbocharger inlet elbow duct (Figure 1, Item 3).

9. Remove bolt, two nuts, and air box with bracket from vehicle.

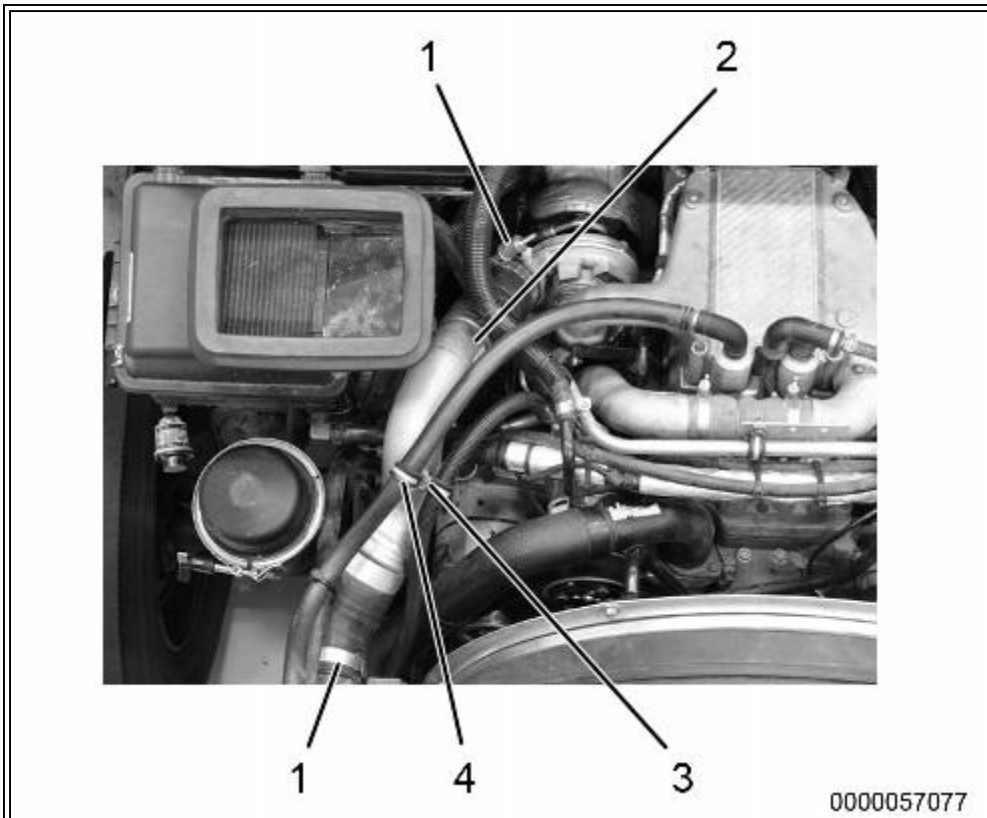
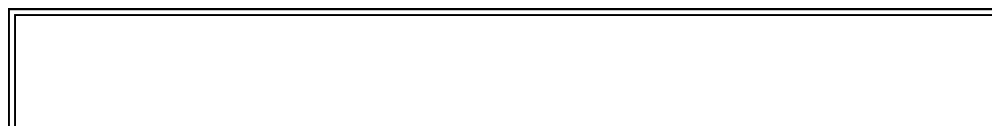

Figure 2. HPCAC Duct.

- 1. Clamp (2)
- 2. HPCAC duct
- 3. Bolt
- 4. P-clamp

10. Remove bolt (Figure 2, Item 3) from P-clamp (Figure 2, Item 4) on HPCAC duct (Figure 2, Item 2).

11. Loosen two clamps (Figure 2, Item 1) and remove HPCAC duct (Figure 2, Item 2).



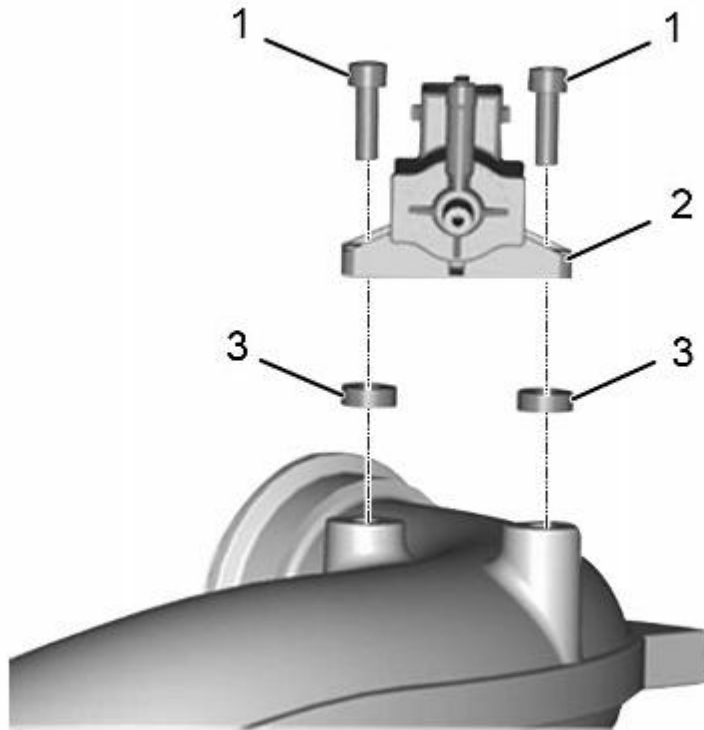
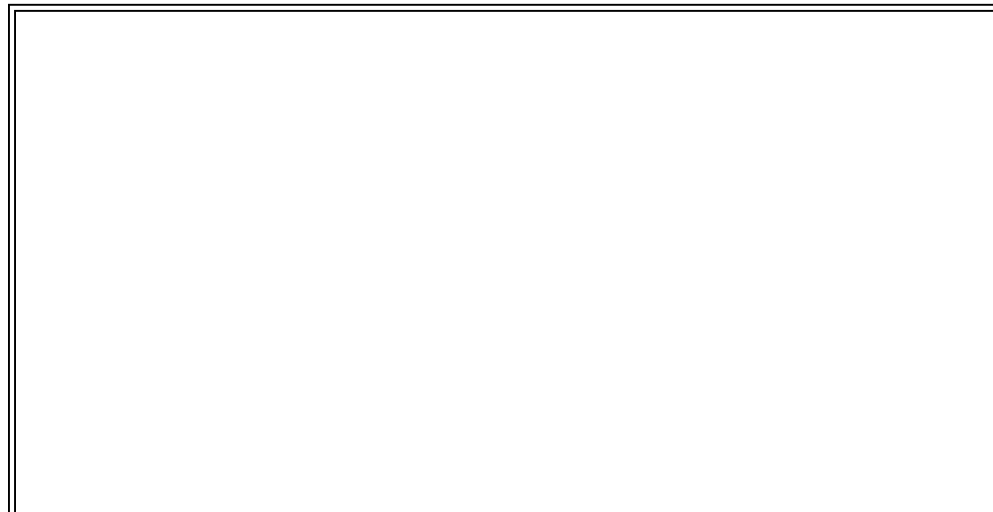

Figure 3. Turbocharger 2 Wastegate Control (TC2WC) Valve.

- 1. Bolt (2)
- 2. TC2WC
- 3. Insulator (2)

NOTE: Perform Steps 12 and 13 of removal procedure if the engine is not equipped with Interstage Cooler (ISC).

12. Remove two bolts (Figure 3, Item 1) and insulators (Figure 3, Item 3) from TC2WC valve (Figure 3, Item 2) and position for access to High Pressure (HP) turbocharger.



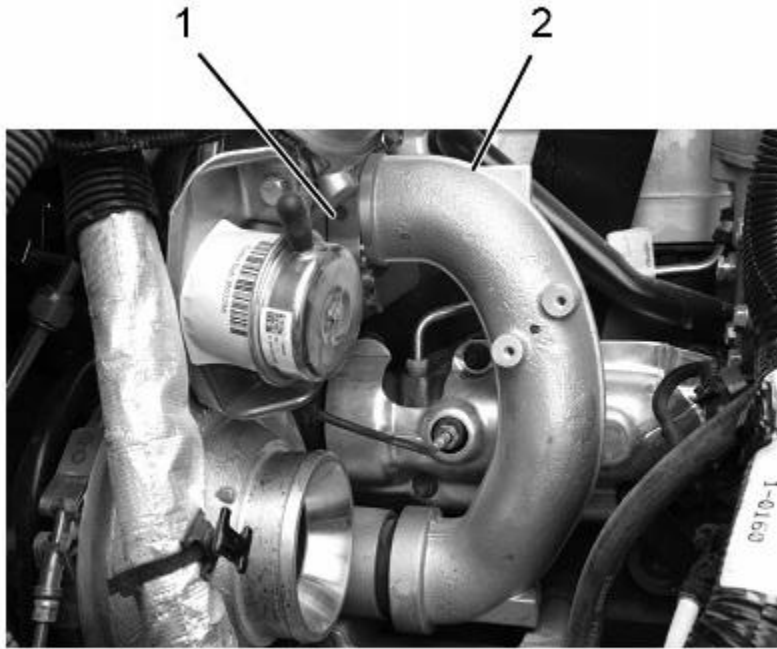

Figure 4. Crossover Tube.

- 1. V-band clamp**
- 2. Crossover tube**

13. Remove V-band clamp (Figure 4, Item 1) and crossover tube (Figure 4, Item 2).



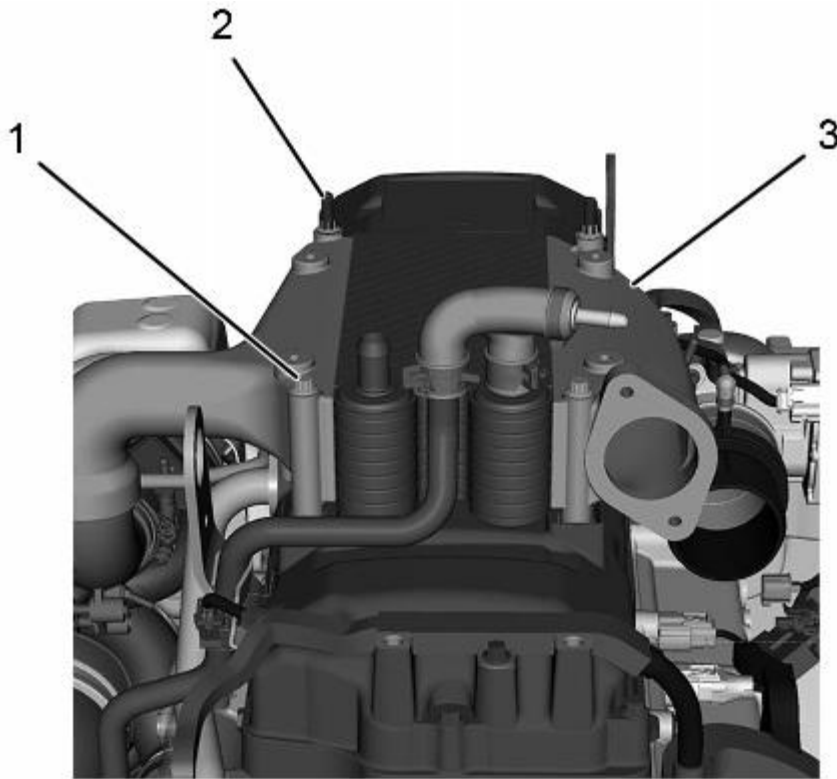

Figure 5. Interstage Cooler (ISC).

- 1. M8 x 110 bolt (2)**
- 2. M8 x 110 stud bolt (2)**
- 3. Interstage cooler (ISC)**

NOTE: Perform Steps 14 through 17 of removal procedure if equipped with Interstage Cooler (ISC).

14. Remove two bolts (Figure 5, Item 1) and stud bolts (Figure 5, Item 2) from Interstage Cooler (ISC) (Figure 5, Item 3).

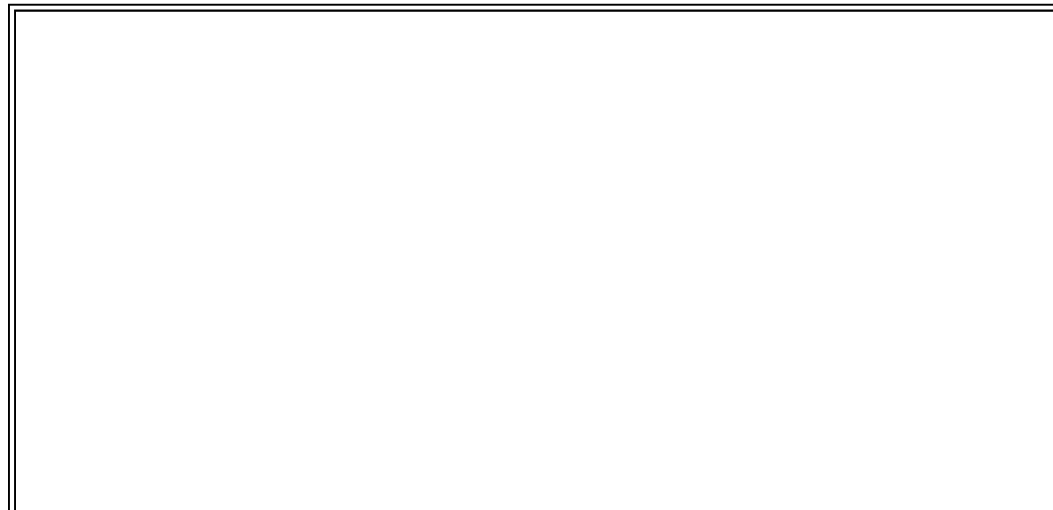



Figure 6. Turbocharger Inlet Elbow.

- 1. Turbocharger inlet elbow**
- 2. V-band clamp**

15. Remove V-band clamp (Figure 6, Item 2) from turbocharger inlet elbow (Figure 6, Item 1).

16. Raise ISC from valve cover and remove turbocharger inlet elbow.

17. Remove crossover tube lip seal using ISC Seal Remover tool according to removal procedure in the Dual Stage Turbocharger and Exhaust Brake section of the EGES-450 Engine Service Manual.



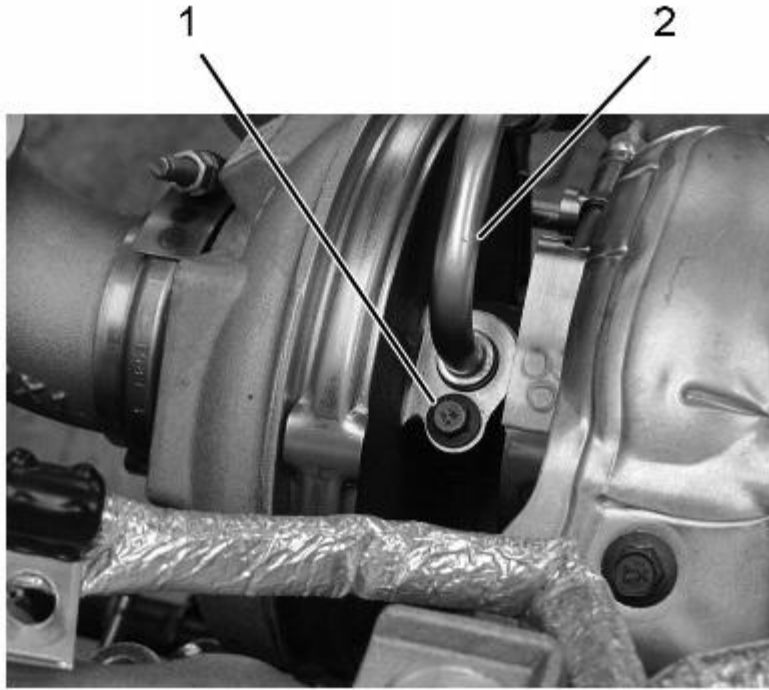

Figure 7. HP Turbocharger Oil Supply Tube.

- 1. M6 x 16 bolt**
- 2. Oil supply tube assembly**

18. Remove bolt (Figure 7, Item 1) from oil supply tube (Figure 7, Item 2). Discard bolt.

19. Apply rust penetrating oil to oil supply tube (Figure 7, Item 2) and disconnect from HP turbocharger.

20. Remove and discard oil supply tube O-ring.

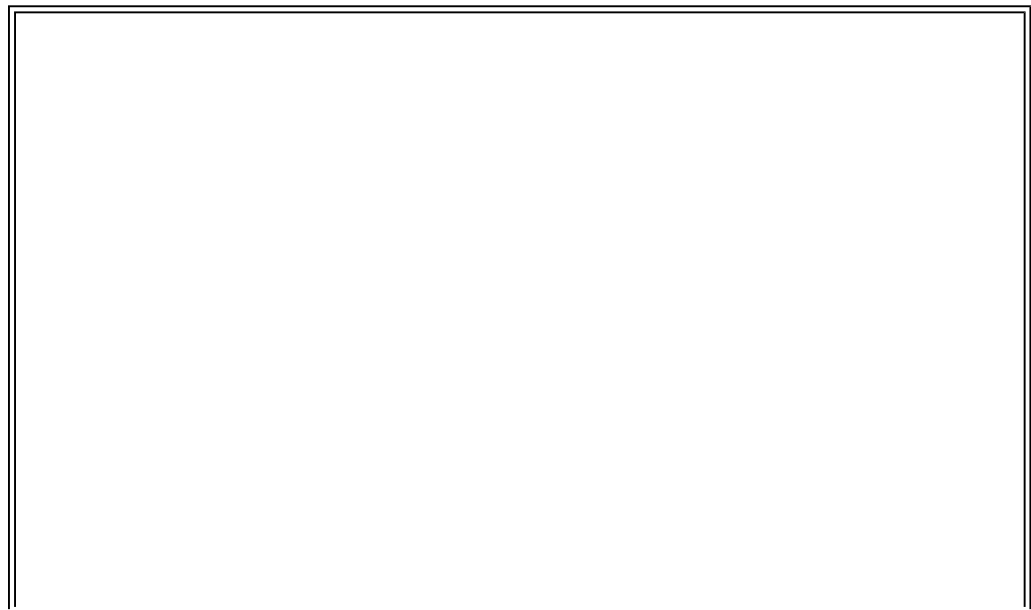

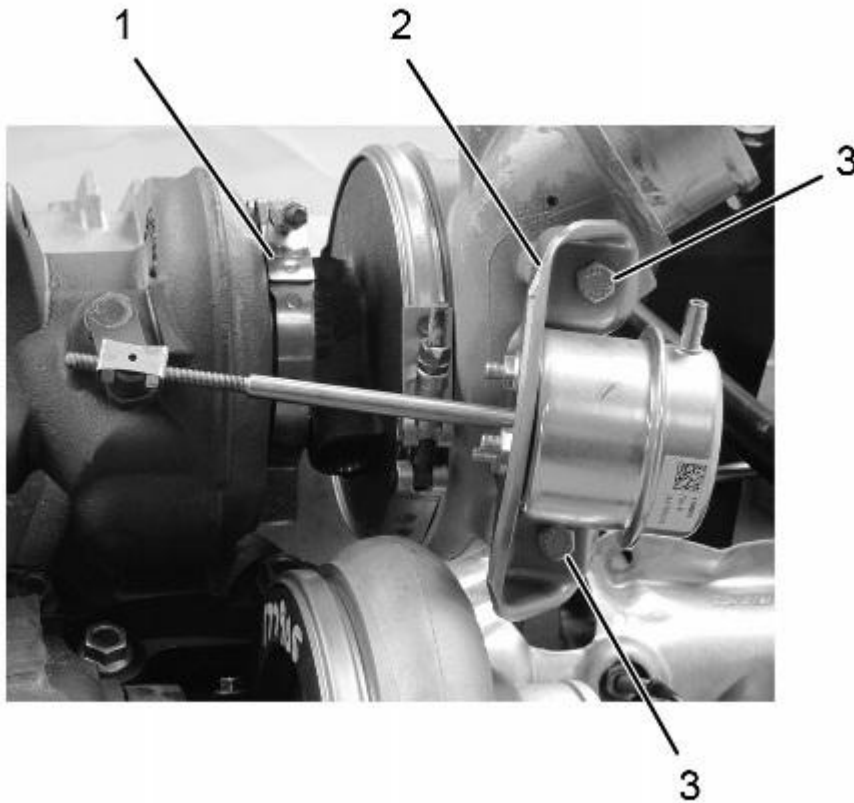

Figure 8. Wastegate Actuator.

- 1. Turbine v-band clamp
- 2. Wastegate actuator
- 3. M8 x 16 bolt (2)

CAUTION: When positioning wastegate actuator for access to HP turbocharger, make sure not to bend or damage wastegate actuator rod, and make sure not to position in a way that adjustment would be compromised. Failure to do so may result in damage to equipment.

21. Remove two bolts (Figure 8, Item 3) and position wastegate actuator (Figure 8, Item 2) for access to HP turbocharger.

22. Remove turbine V-band clamp (Figure 8, Item 1) from HP turbocharger.

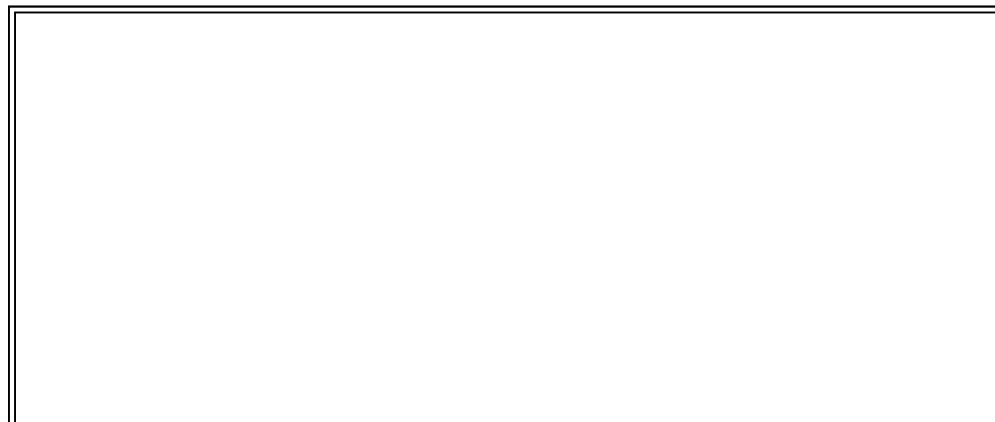

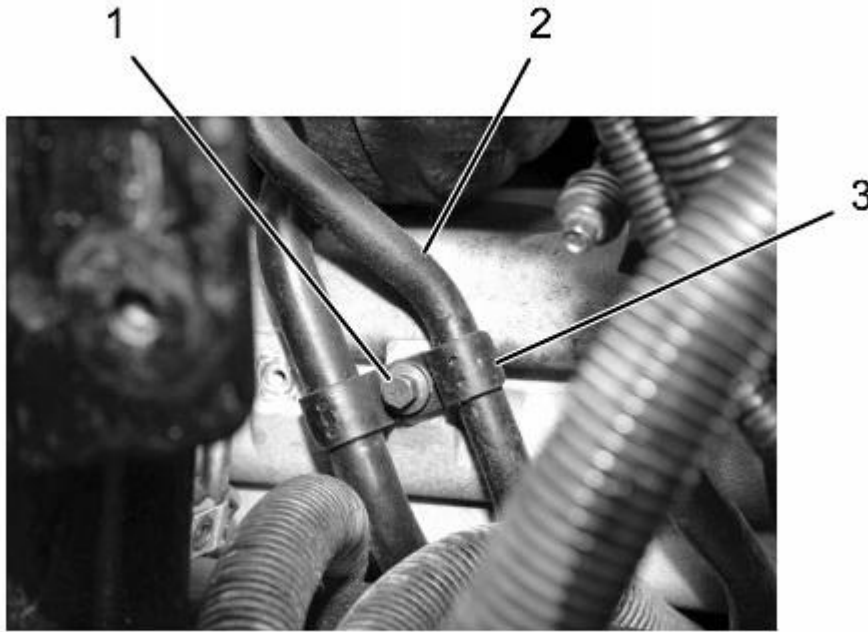

Figure 9. Oil Drain Tube.

- 1. Bolt**
- 2. Oil drain tube**
- 3. P-clamp**

23. Remove bolt (Figure 9, Item 1) from P-clamp (Figure 9, Item 3) on oil drain tube (Figure 9, Item 2).

24. Using a soft-blow mallet, tap HP turbocharger center section until loose and remove from turbine housing and oil drain tube.

25. Using a clean emery cloth, clean turbine housing and mating surfaces.

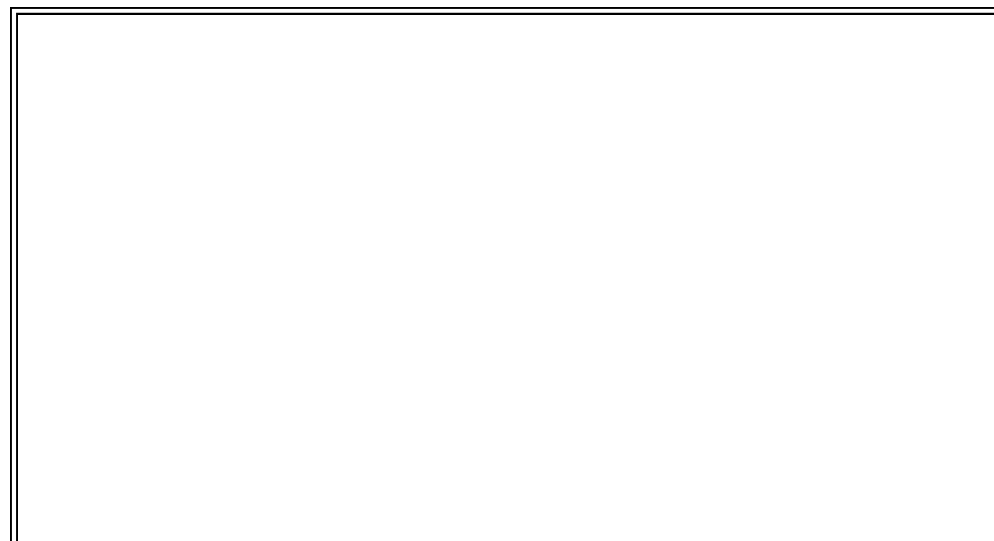

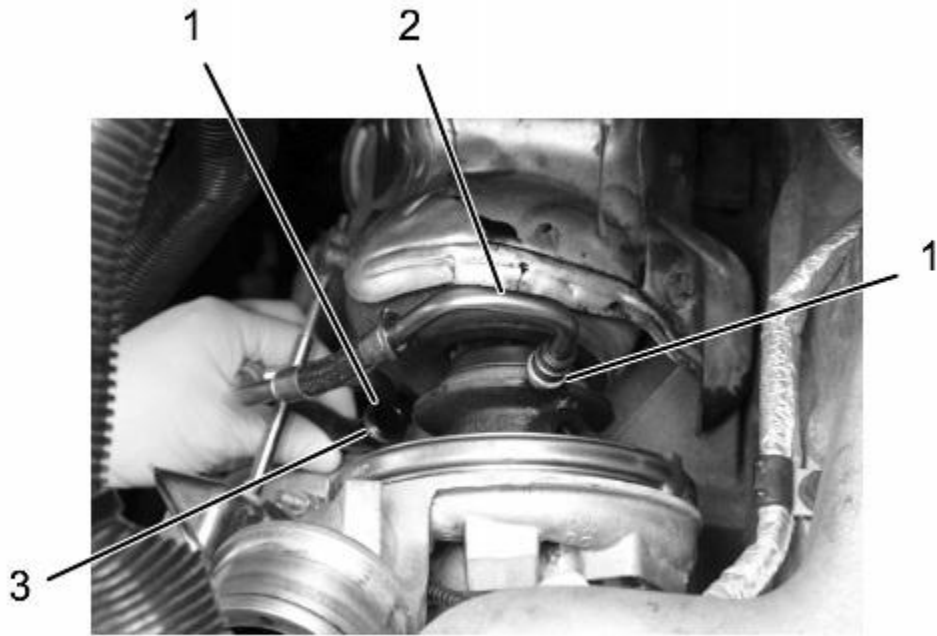

Figure 10. O-rings.

- 1. O-ring (2)
- 2. Oil supply tube
- 3. Oil drain tube

26. Remove HP turbocharger oil drain O-ring (Figure 10, Item 1). Discard O-ring.

27. Place new high pressure turbocharger on bench.

28. On the new high pressure turbocharger remove the 2 actuator bolts.

29. Remove the turbine V-band clamp and save for installation on new turbocharger center section on engine.

30. Remove new turbo center section from new turbine housing.

INSTALLATION

NOTE: Make sure to lubricate O-rings with P-80® or equivalent lubricant.

1. Install new O-ring (Figure 10, Item 1) onto oil drain tube (Figure 10, Item 3).

2. Install new O-ring (Figure 10, Item 1) onto oil supply tube (Figure 10, Item 2).

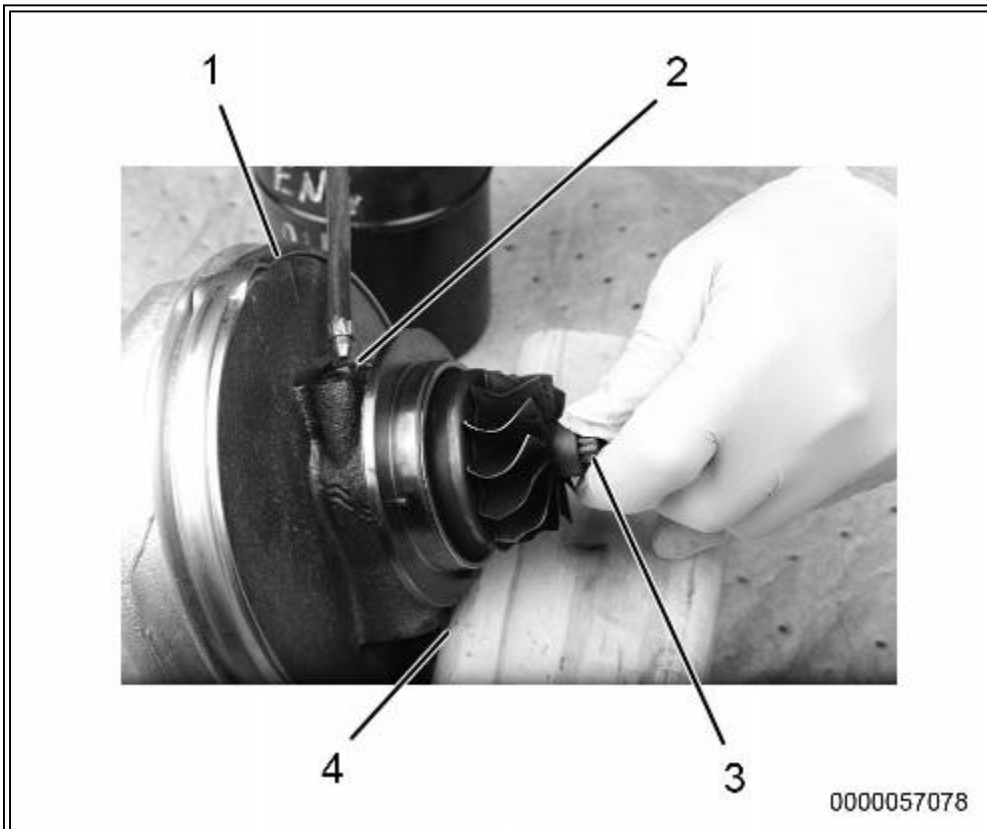

Figure 11. Priming HP Turbocharger Center Section.

- 1. HP turbocharger center section
- 2. Oil supply port
- 3. Turbine wheel nut
- 4. Oil drain port

3. Using 15W40 engine oil, prime new HP turbocharger center section (Figure 11, Item 1) oil supply port (Figure 11, Item 2) while spinning by turbine wheel nut (Figure 11, Item 3) until oil is seen seeping from oil drain port (Figure 11, Item 4).

WARNING: Make sure oil drain tube is fully seated in HP turbocharger center section while installing HP turbocharger into turbine housing. Failure to comply may result in injury to personnel and / or damage to equipment.

4. Install new HP turbocharger center section onto the HP oil drain tube while installing into the turbine housing.

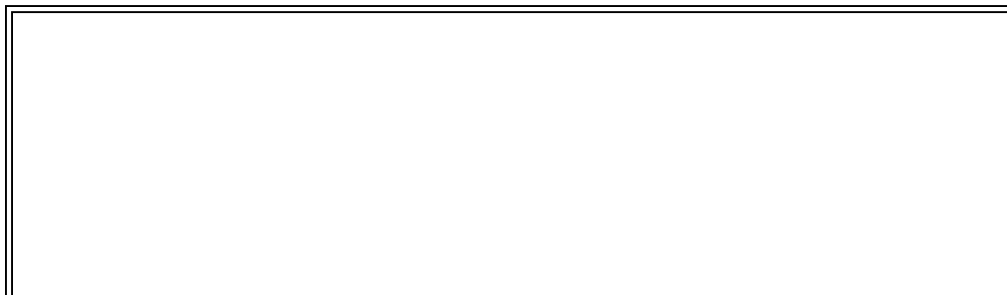

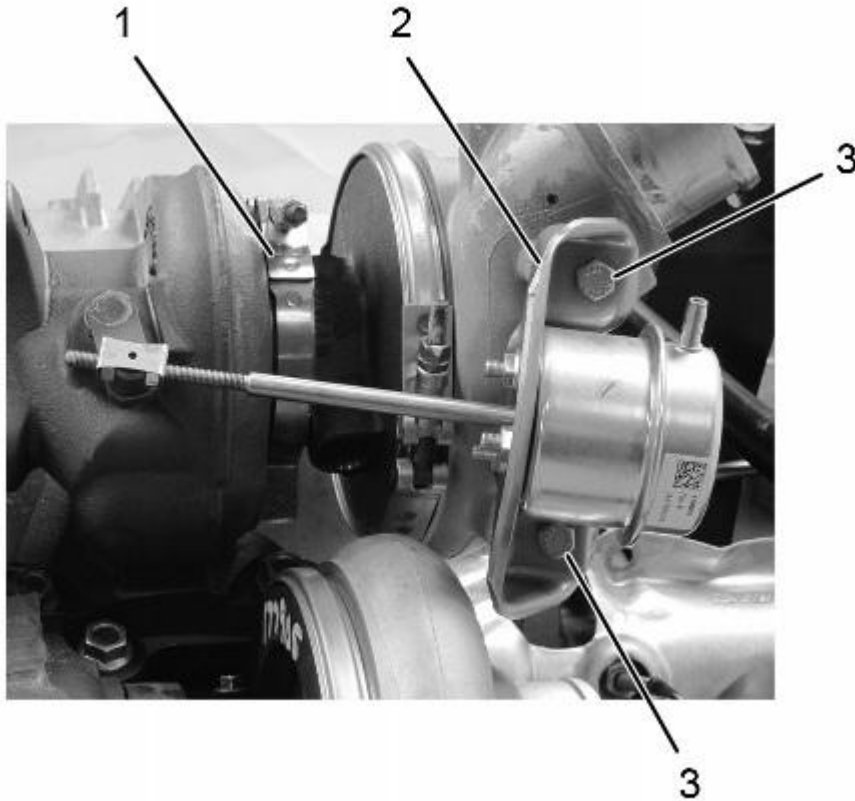

Figure 12. Wastegate Actuator.

- 1. Turbine v-band clamp
- 2. Wastegate actuator
- 3. M8 x 16 bolt (2)

5. Install turbine V-band clamp (Figure 12, Item 1) on HP turbocharger.

6. Using torque wrench, torque turbine V-band clamp (Figure 12, Item 1) to 13 lb-ft (17 N•m).

CAUTION: When installing wastegate actuator, make sure not to bend or damage wastegate actuator rod, and make sure not to position in a way that adjustment would be compromised. Failure to do so may result in damage to equipment.

7. Install wastegate actuator (Figure 12, Item 2) with two bolts (Figure 12, Item 3).



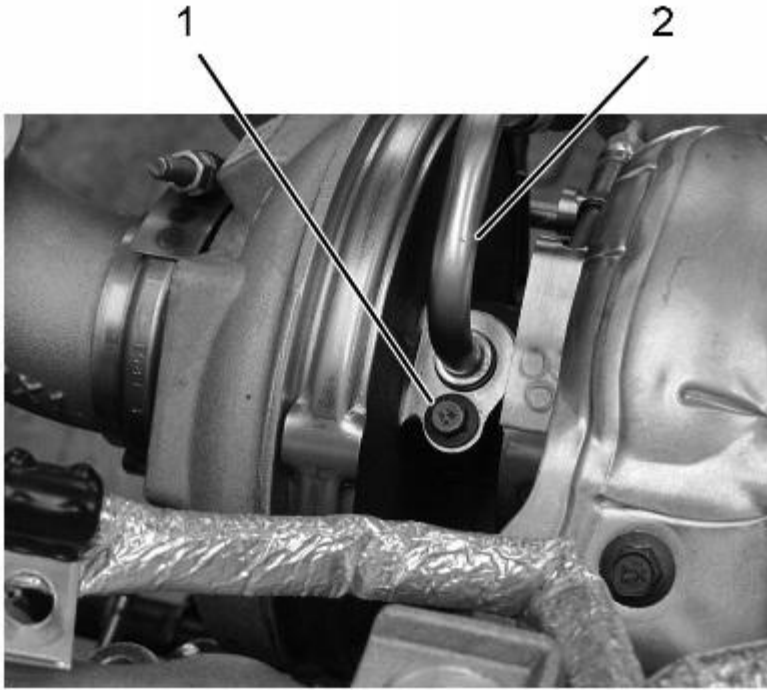

Figure 13. Oil Supply Tube.

- 1. M6 x 16 bolt**
- 2. Oil supply tube assembly**

8. Connect oil supply tube (Figure 13, Item 2) to HP turbocharger.

9. Install oil supply tube (Figure 13, Item 2) with M6 X 16 bolt (Figure 13, Item 1).



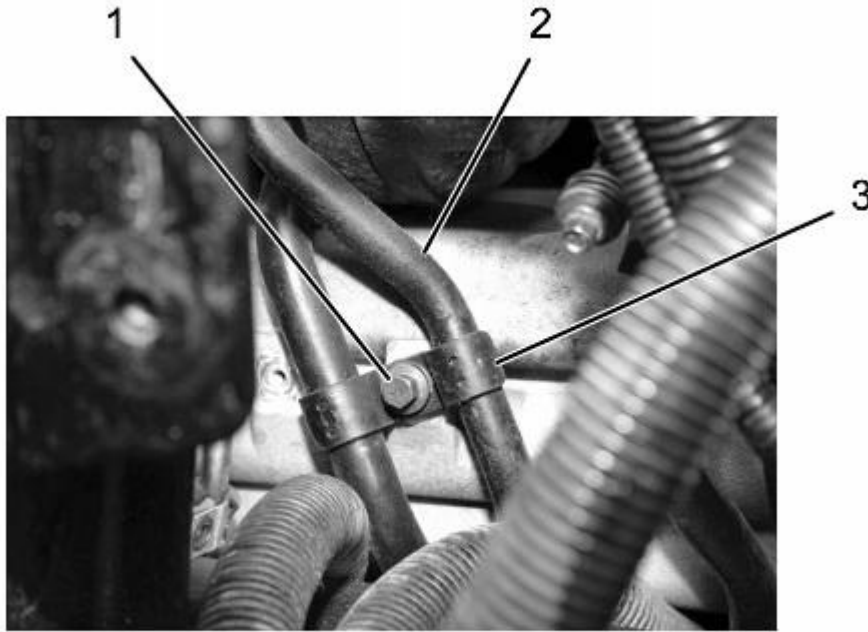

Figure 14. Oil Drain Tube.

- 1. Bolt**
- 2. Oil drain tube**
- 3. P-clamp**

10. Install bolt (Figure 14, Item 1) in P-clamp (Figure 14, Item 3) on oil drain tube (Figure 14, Item 2).



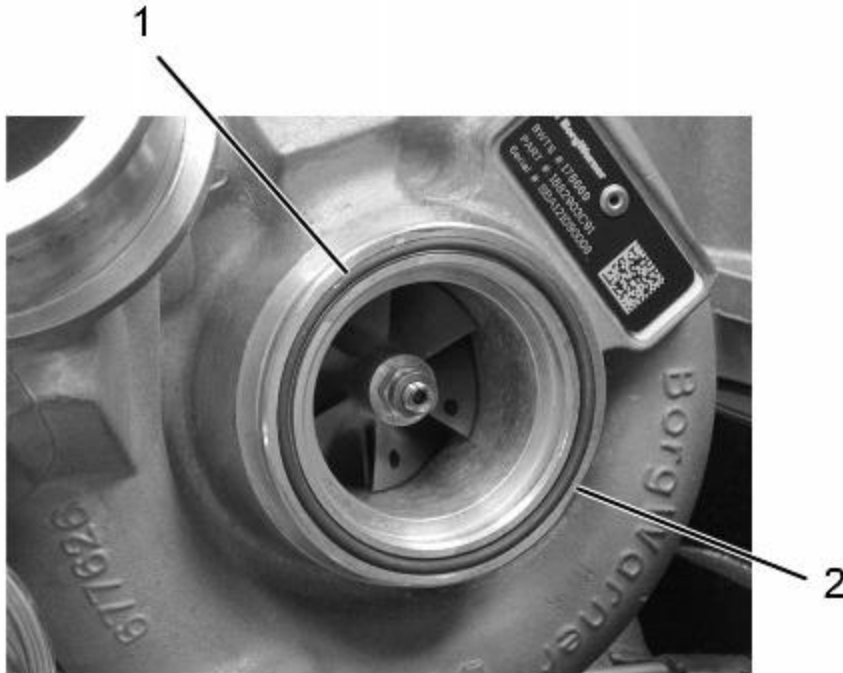

Figure 15. HP Turbocharger O-Ring.

- 1. 2.62 X 61.6 ID o-ring**
- 2. HP turbocharger**

11. Install new O-ring (Figure 15, Item 1) into groove on HP turbocharger (Figure 15, Item 2).



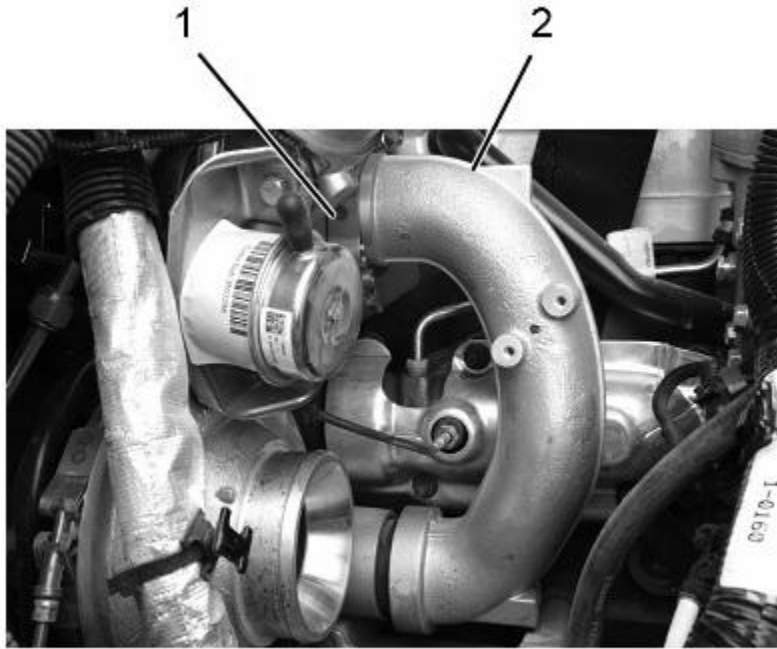

Figure 16. Crossover Tube.

- 1. V-band clamp
- 2. Crossover tube

NOTE: Perform Steps 12 through 15 of installation procedure if not equipped with ISC.

12. Inspect crossover tube (Figure 16, Item 2) seal for damage. If damaged, discard seal.

13. Apply P-80 or equivalent to outside of crossover tube seal and inside of interstage inlet duct. Push crossover tube onto crossover tube seal until it pops into place.

14. Install crossover tube (Figure 16, Item 2) on to HP turbocharger with V-band clamp (Figure 16, Item 1).

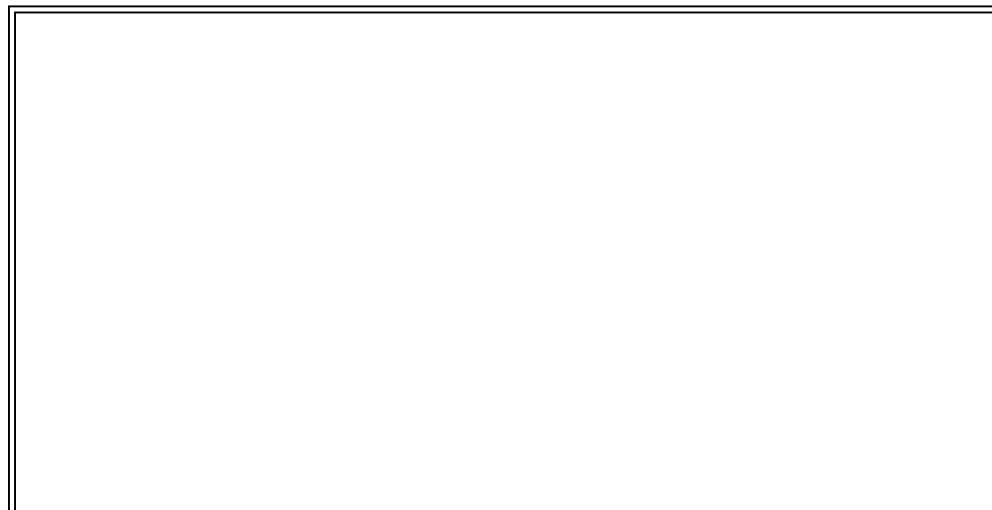

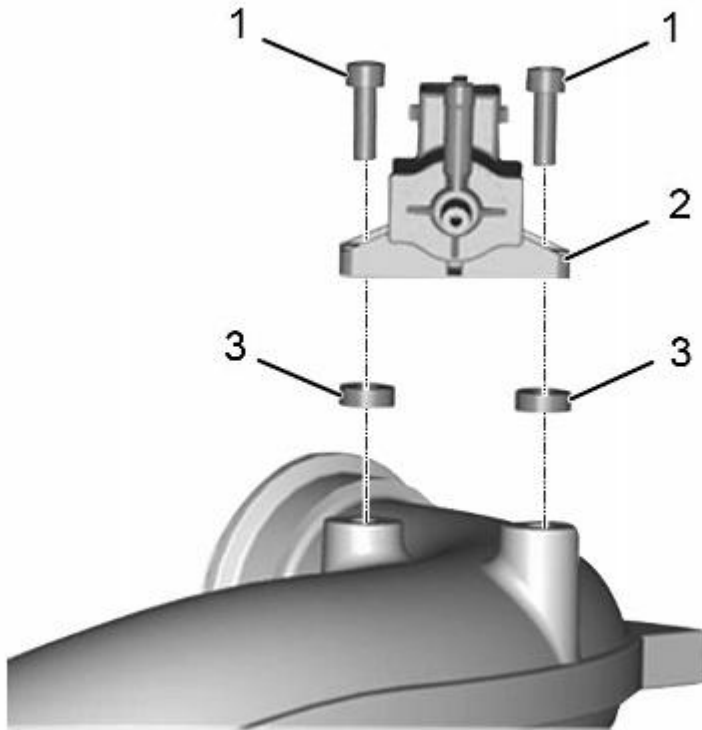

Figure 17. Turbocharger 2 Wastegate Control (TC2WC) Valve.

- 1. Bolt (2)**
- 2. TC2WC valve**
- 3. Insulator (2)**

15. Install TC2WC valve (Figure 17, Item 2) onto crossover tube with two insulators (Figure 17, Item 3) and bolts (Figure 17, Item 1).

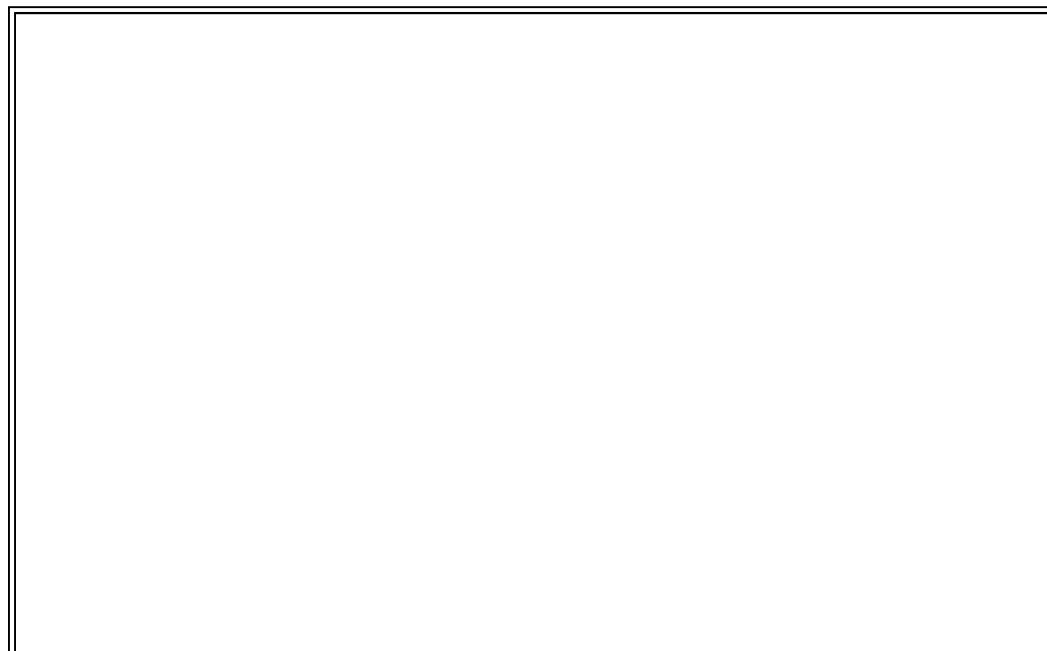

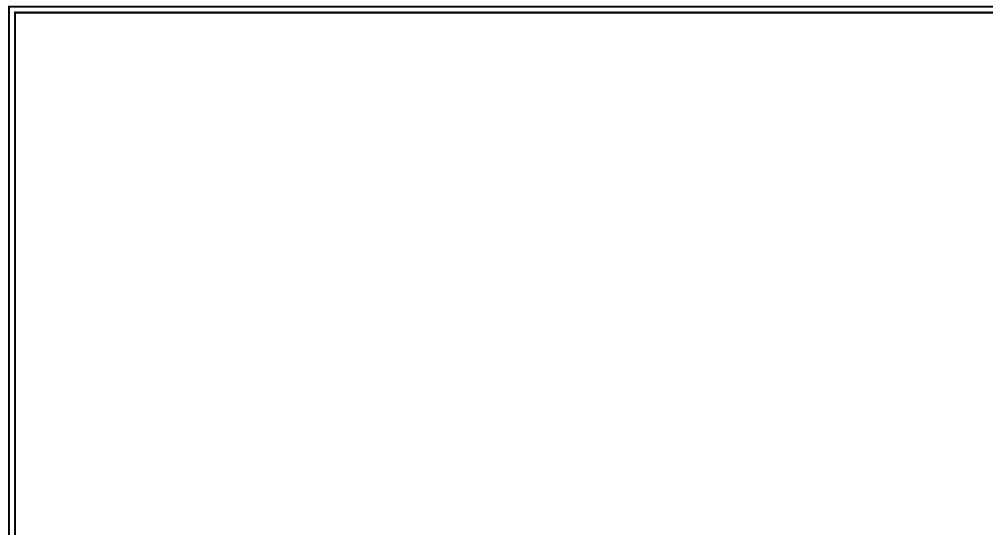

Figure 18. Turbocharger Inlet Elbow.

- 1. Turbocharger inlet elbow**
- 2. V-band clamp**

NOTE: Perform Steps 16 through 20 of installation procedure if the engine is equipped with an ISC.

16. Position turbocharger inlet elbow (Figure 18, Item 1) onto HP turbocharger with V-band clamp (Figure 18, Item 2) hand tight.



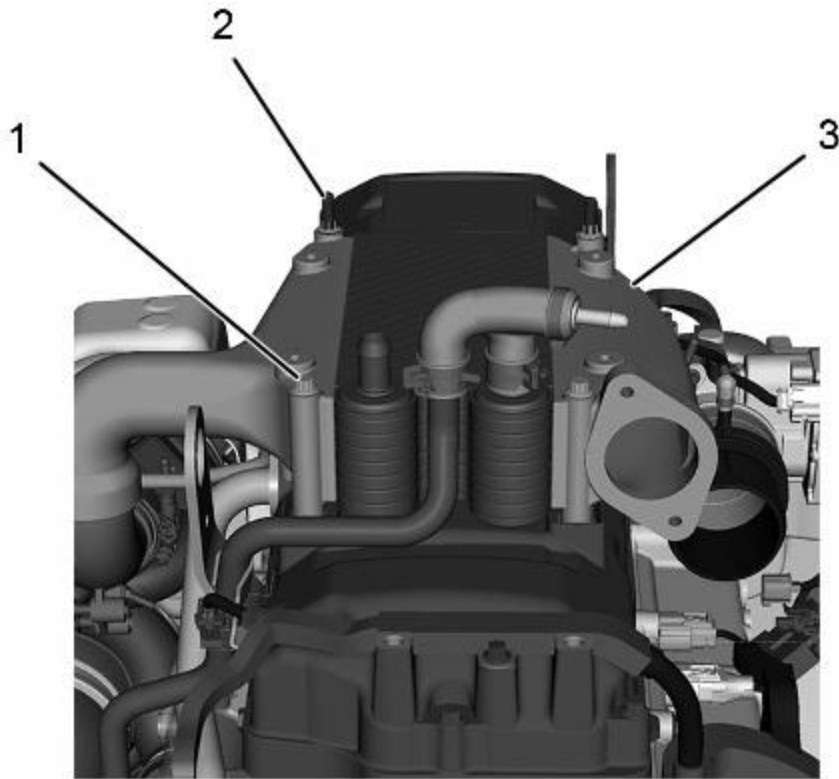

Figure 19. Interstage Cooler (ISC).

- 1. M8 x 110 bolt (2)**
- 2. M8 x 110 stud bolt (2)**
- 3. Interstage cooler (ISC)**

17. Install new ISC outlet lip seal.

18. Install ISC (Figure 19, Item 3) onto turbocharger inlet elbow and valve cover with two bolts (Figure 19, Item 1) and two stud bolts (Figure 19, Item 2).

19. Using torque wrench, torque bolts and stud bolts to 23 lb-ft (31 N•m).

20. Using torque wrench, torque V-band clamp to 13 lb-ft (17 N•m).

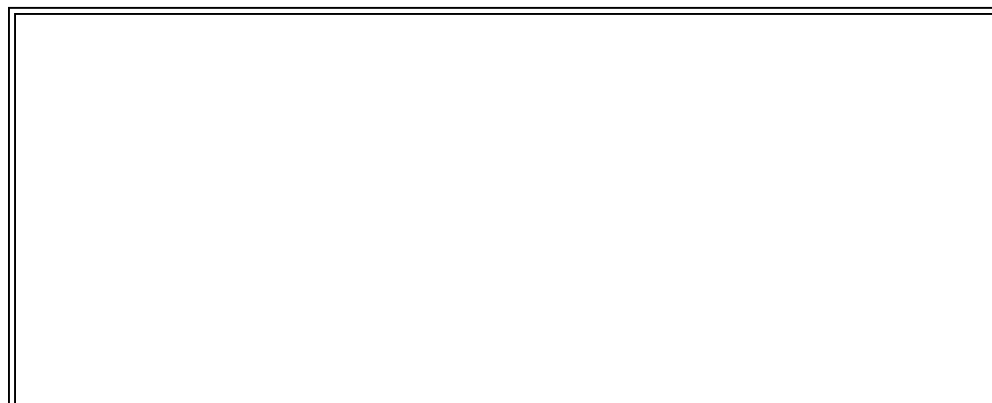

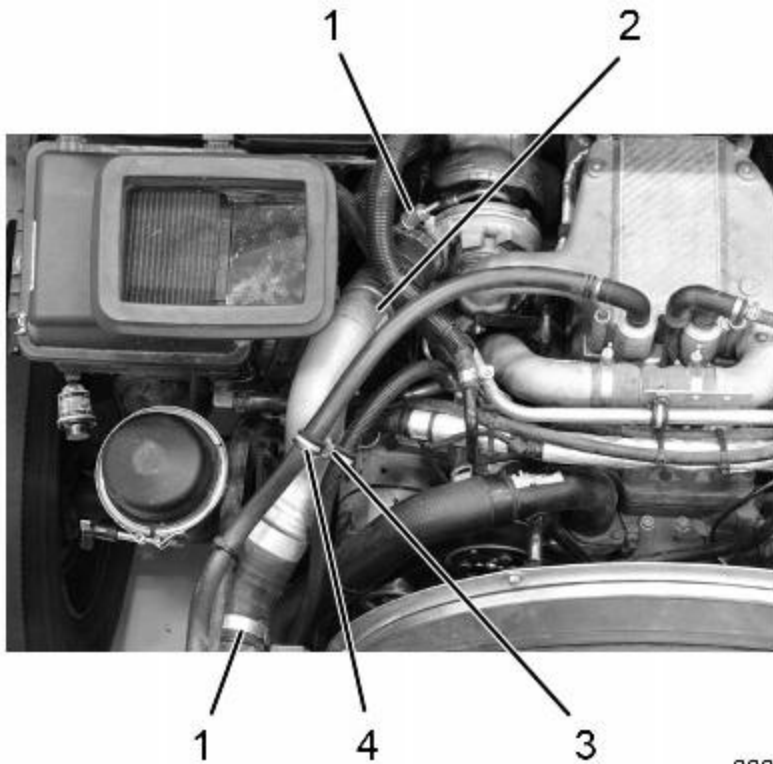

Figure 20. HPCAC Duct.

- 1. Clamp (2)**
- 2. HPCAC duct**
- 3. Bolt**
- 4. P-clamp**

21. Install HPCAC duct (Figure 20, Item 2) with two clamps (Figure 20, Item 1) .

22. Install bolt (Figure 20, Item 3) in P-clamp (Figure 20, Item 4) on HPCAC duct (Figure 20, Item 2).

23. Install air box and bracket with nut and two bolts.

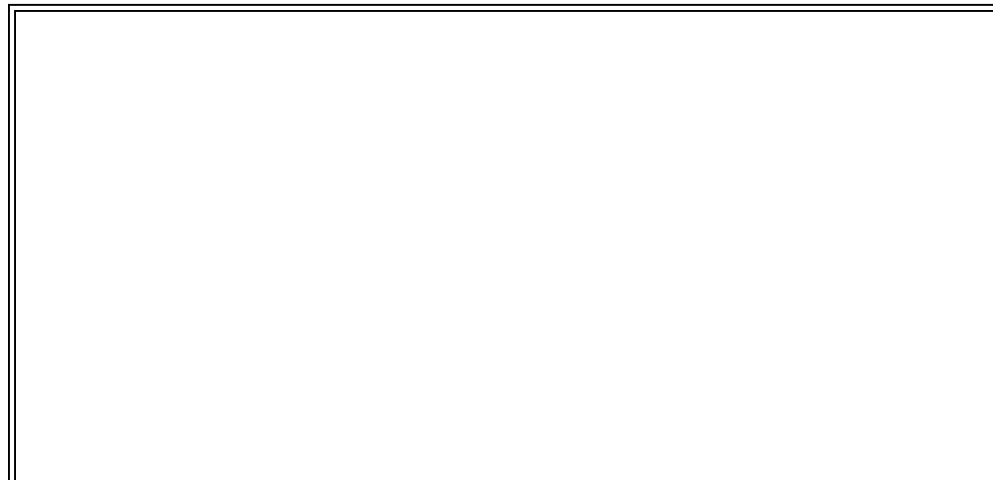

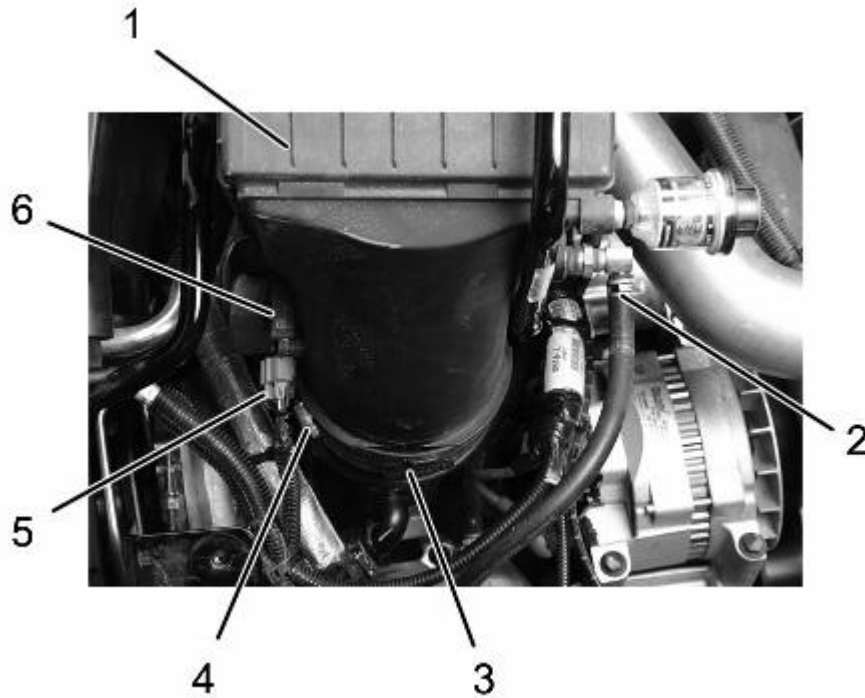

Figure 21. MAF Sensor and Air Compressor Inlet Hose.

1. Air box
2. Air compressor inlet hose
3. LP turbocharger inlet elbow duct
4. LP turbocharger inlet elbow duct clamp
5. MAF sensor connector
6. MAF sensor

23. Install air box outlet into LP turbocharger inlet elbow duct (Figure 21 Item 3) and torque clamp (Figure 21 Item 4).

24. Connect air compressor inlet hose (Figure 21, Item 2) to air box (Figure 21, Item 1).

25. Connect MAF sensor connector (Figure 21, Item 5) to MAF sensor (Figure 21, Item 6).

26. Install right side inner fender with four washers and bolts.

27. Connect negative battery cable and close battery box.

28. Run engine to verify proper operation, no leaks, and no fault codes.

29. Close and latch hood.

30. Remove wheel chocks.

31. Connect to truck with EZ-Tech and using ServiceMaxx recalibrate the Mass Air Flow (MAF) Sensor.

 Hide Details

Feedback Information

Viewed: 560

Helpful: 7

Not Helpful: 1

No Feedback Found

Copyright © 2013 Navistar, Inc.