



This Service Information bulletin supersedes SI 18 05 12 dated July 2012.

PERFORM THE PROCEDURE OUTLINED IN THIS SERVICE INFORMATION ON ALL AFFECTED VEHICLES BEFORE CUSTOMER DELIVERY OR THE NEXT TIME THEY ARE IN THE SHOP FOR MAINTENANCE OR REPAIRS.

BMW centers must ensure recalls are completed after having been notified by BMW of North America, LLC (BMWNA) that a safety-related defect or noncompliance exists in any motor vehicle or item of replacement equipment in the center's possession at the time of notification. In BMW NA's case, this notification would typically be made by the issuance of a recall notification in the form of a Service Information bulletin (SIB) or transmission of a Dealer Communication System (DCS) recall message.

Under the National Traffic and Motor Vehicle Safety Act of 1966, as amended, if a recall campaign is announced by BMW NA, centers must ensure that all recalls on new vehicles and new items of replacement equipment are completed BEFORE delivery to the consumer. This means that centers may not legally deliver new motor vehicles or new items of replacement equipment to consumers with an open recall.

The Safety Act also prohibits centers from selling or leasing the motor vehicle or item of replacement equipment, unless and until the open recall has been completed BEFORE delivery. This also pertains to vehicles in the Certified Pre-Owned program, and to items of replacement equipment.

Finally, BMW centers should not sell or use parts that have been recalled by BMW NA. Please follow the specific instructions provided by BMW NA on the return or disposition of the parts.

NEW designates changes to this revision

SUBJECT

Voluntary Emissions Recall Campaign 11E-A03: Check and/or Replace Emissions Monitoring Components

MODEL

E70 and E90 with the M57Y engine produced from April 2009 to September 2010

SITUATION

1. Under certain driving conditions, the High-pressure (HP) EGR valve may become restricted with excessive soot. This restriction impedes the emissions performance of the HP EGR valve. This situation may lead to a Service Engine Soon lamp. An optimized EGR valve has been developed to limit this soot buildup.
2. The Selective Catalyst Reduction (SCR) mixer has also been improved to optimize the Diesel Exhaust Fluid (DEF) mixture when introduced into the exhaust system.

Note: These Improved parts may have already been replaced during a previous service visit. It will be necessary to inspect these components first before replacement.

3. Reprogramming of the DDE is required to optimize these improved emissions monitoring components.

AFFECTED VEHICLES

This Emissions Recall Campaign involves X5d (E70) and 335d (E90) models that were produced from April 2009 to March 2011.

In order to determine whether a specific vehicle has had this Emissions Recall Campaign completed or is affected by this Emissions Recall Campaign, first check if the "Emissions Recall Campaign Completed" label SD 92-435. This label is attached to the right (passenger) rear side of the hood in the engine compartment, close to the windshield.

If the label is found, the campaign has already been performed. If the "Emissions Recall Campaign Completed" label is not present, it will be necessary to utilize the "Service Menu" of DCSnet (Dealer Communication System) or the Key Reader. Based on the response of the system, either proceed with the corrective action or take no further action.

CORRECTION

Inspecting the mixer:

Remove the Selective Catalyst Reduction (SCR) catalyst from the exhaust after the particulate filter to gain access to the mixer.

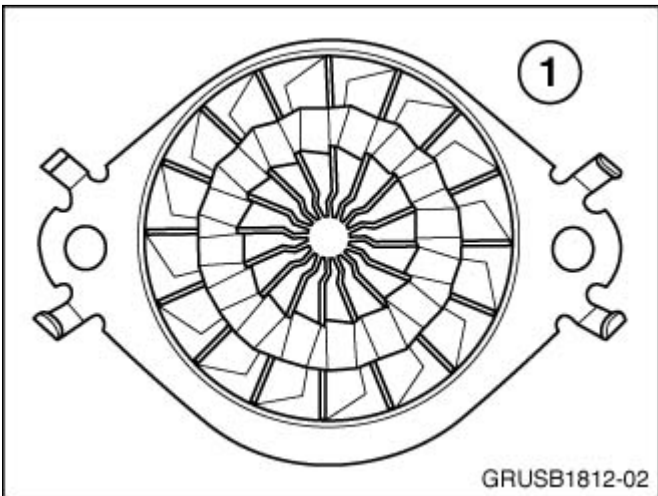
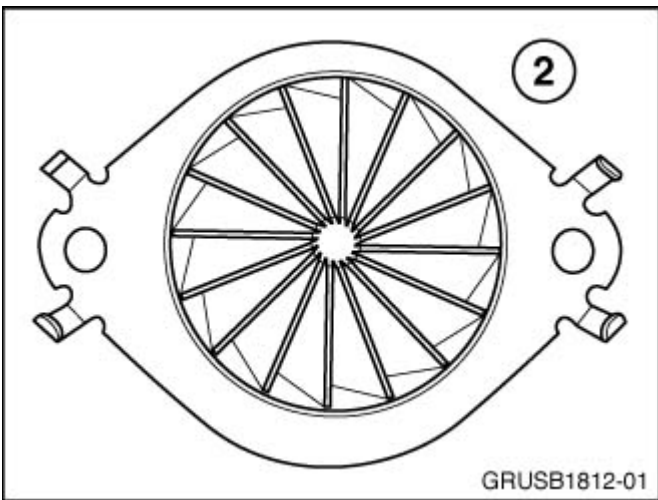
| | |
|--|--|
|  | <p>The original style mixer has a multiple fin arrangement (1). This mixer will need to be replaced with P/N 18 30 8 513 445 (E70) or P/N 18 30 8 512 438 (E90).</p> |
|  | <p>If the updated mixer has already been installed, it will have one set of fins (2). No replacement is necessary. Reinstall the SCR front pipe to the down pipe of the DPF.</p> |

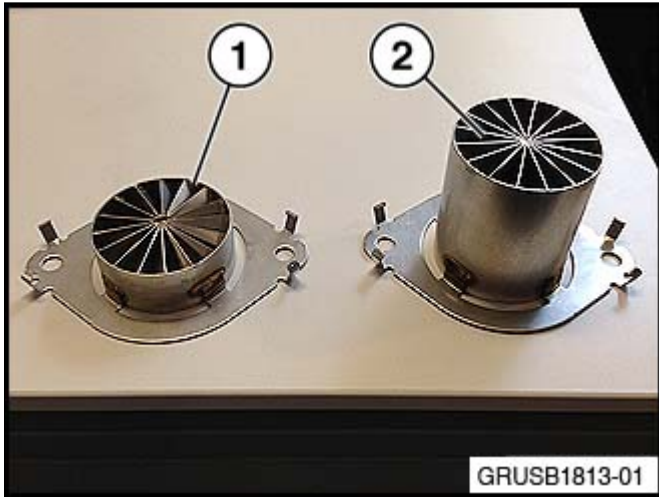

NEW 1. The E90 mixer (1) is shorter than the E70 mixer (2).

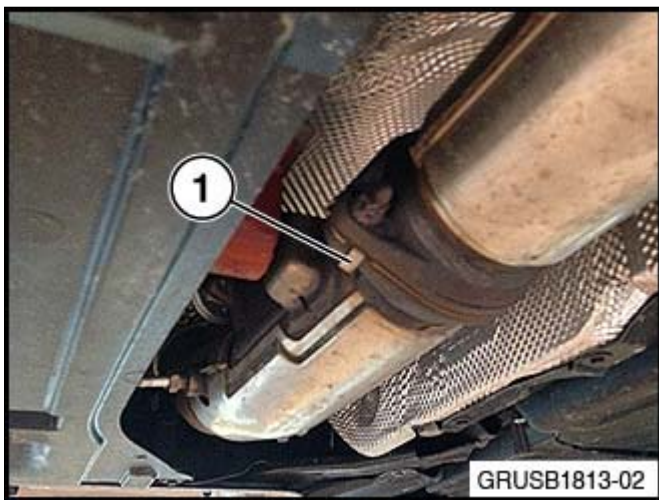

NEW 1. The barrel of the E70 mixer points toward the front of the car. This is easily identified by the mixer tabs wrapped around the front pipe flange (1).

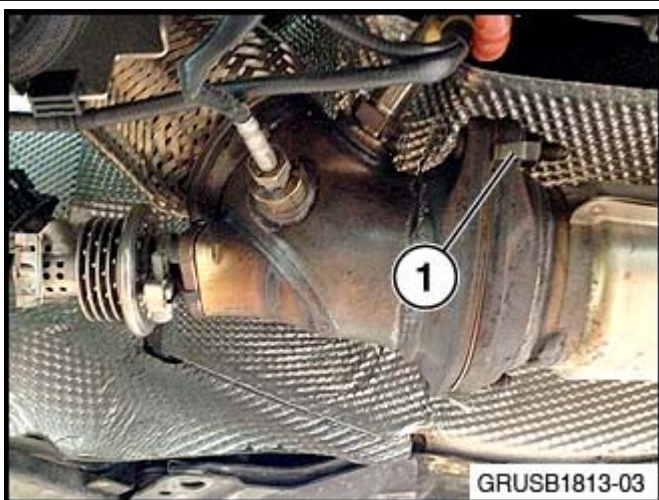

NEW 1. The barrel of the E90 mixer points toward the rear of the car. This is identified by the mixer tabs wrapped around the flange on the SCR cat (1).

Inspecting the EGR valve:

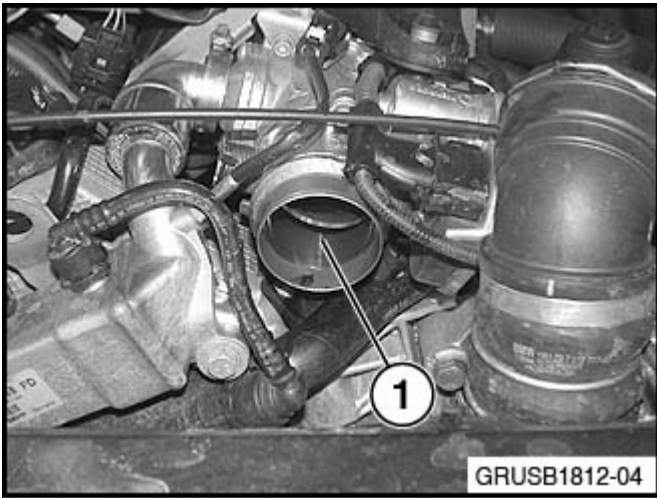

Remove the charge air pipe at the throttle housing (ignition off). Using a flashlight, look through the throttle (1) and inspect the EGR valve.

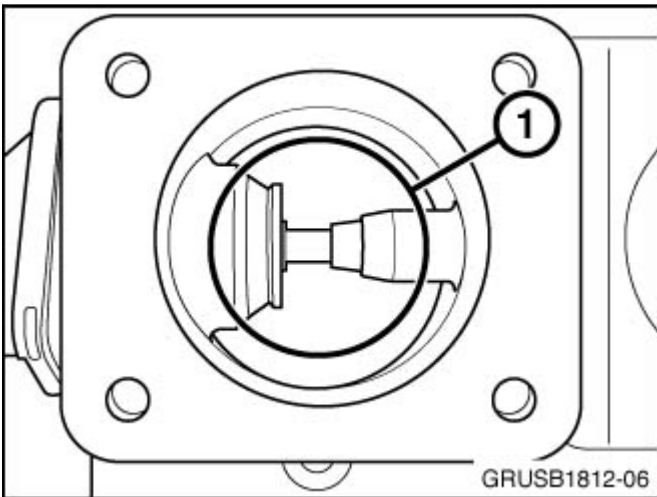

The updated EGR valve (P/N 11 71 8 517 217 or P/N 11 71 8 512 526) has the valve and seat directly in the airstream of the throttle (1). If this valve is installed, no further action is needed. Reinstall the charge air pipe.

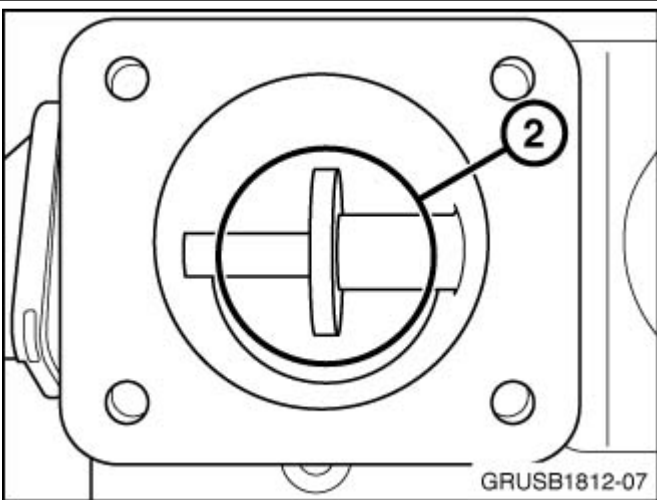

The original EGR valve has a diffuser in the airstream flow from the throttle (2). The valve for EGR actuation is seated further into the EGR airstream. Replace this valve with P/N 11 71 8 512 526 (Repair Instruction 11 71 501).

The DDE will also need to be programmed as part of the Recall. If the EGR valve is replaced, the DDE will need to be programmed after the new EGR valve is installed. This new software package contains the necessary software to adapt to the new EGR valve strategy.

Program the vehicle using ISTA/P 2.46.3 or later.

Note that ISTA/P will automatically reprogram and code all programmable control modules that do not have the latest software.

For information on programming and coding with ISTA/P, refer to CenterNet / Aftersales Portal / Service / Workshop Technology / Vehicle Programming.

PARTS INFORMATION

Parts needed to perform inspection and/or replacement of mixer and EGR valve

| Part Number | Description | Quantity |
|--|--------------------------------|----------|
| 11 62 7 509 731 | Collar nut (exhaust) (E70) | 2 |
| 07 14 6 954 889 | Hexagon bolt with collar (E70) | 4 |
| 18 30 7 812 171 | Seal (exhaust) | 2 |
| 22 11 6 775 521 | Isa bolt with washer (E90) | 2 |
| 18 30 7 620 549 | Flanged hexagon nut (E90) | 2 |
| | | |
| | | |
| E70 (EGR valve and/or mixer replaced) | | |
| 18 30 8 513 445 | Mixer (if needed) | 1 |
| 11 71 8 512 526 | EGR valve (if needed) | 1 |
| 13 54 7 792 098 | O-ring | 1 |
| 11 61 2 245 439 | Rubber seal | 1 |
| | | |
| | | |
| E90 (EGR valve and/or mixer replaced) | | |
| 18 30 8 512 438 | Mixer (if needed) | 1 |
| 11 71 8 512 526 | EGR valve (if needed) | 1 |
| 22 11 6 775 521 | Isa bolt with washer | 2 |
| 18 30 7 620 549 | Flanged hexagon nut | 2 |
| 13 54 7 792 098 | O-ring | 1 |
| 11 61 2 245 439 | Rubber seal | 1 |

LABEL INSTRUCTIONS

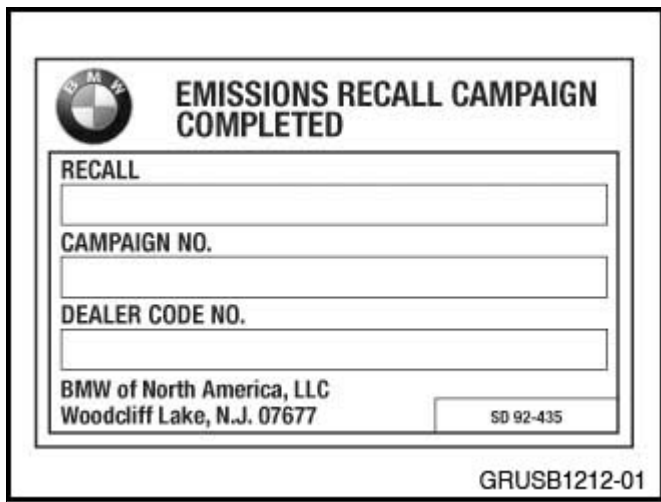

EMISSIONS RECALL CAMPAIGN COMPLETED

RECALL

CAMPAIGN NO.

DEALER CODE NO.

BMW of North America, LLC
 Woodcliff Lake, N.J. 07677

SD 92-435

GRUSB1212-01

After the vehicle has been checked and corrected, obtain a label (SD 92-435) and with the indelible marker provided, legibly print the Recall name, Recall number, and dealer code (5 digits) on the Recall Completion Label (see illustration).

An initial quantity of **100** labels will be sent to all BMW centers. Peel the label from its backing and affix it to the right (passenger) rear side of the hood in the engine compartment, close to windshield.

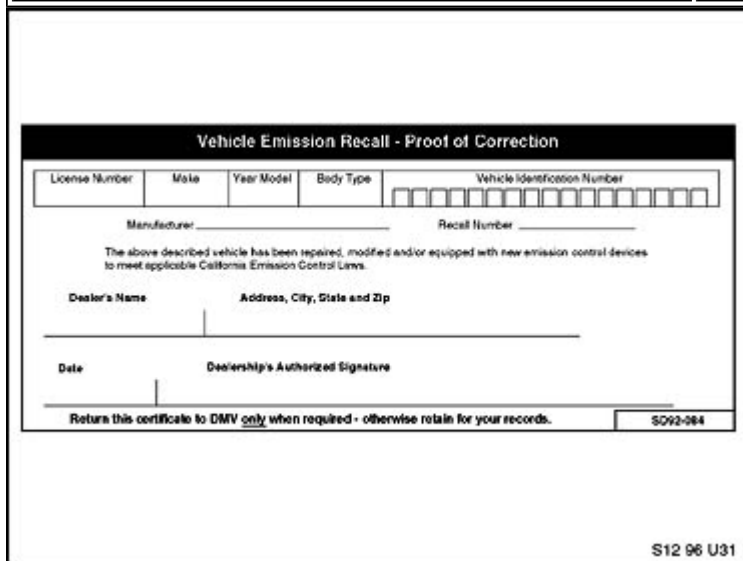

Vehicle Emission Recall - Proof of Correction

| License Number | Make | Year/Model | Body Type | Vehicle Identification Number |
|----------------|------|------------|-----------|-------------------------------|
| | | | | <input type="text"/> |

Manufacturer: _____ Recall Number: _____

The above described vehicle has been repaired, modified and/or equipped with new emission control devices to meet applicable California Emission Control Limits.

Dealer's Name: _____ Address, City, State and Zip: _____

Date: _____ Dealership's Authorized Signature: _____

Return this certificate to DMV only when required - otherwise retain for your records. SD92-084

S12 96 U31

For California centers only: it is required by the California code of regulations that an executed orange "vehicle emission recall - proof of correction" certificate (SD92-084, see illustration) be provided to each customer (for vehicles registered in the state of California), once the Recall on his or her vehicle has been completed.

Note: Additional labels can be ordered online at BMW TIS.

WARRANTY INFORMATION

The repair described in this bulletin is covered under warranty regardless of time or mileage.

Reimbursement for this Recall will be via normal claim entry utilizing the following information:

Refer to KSD2 for the corresponding flat rate unit (FRU) allowance. Enter the Chassis Number, which consists of the last 7 digits of the Vehicle Identification Number (VIN). Click on the "Search" button, and then enter the applicable flat rate labor operation in the FR code field.

If FRU labor allowance is not available in KDS2, then use the FRU allowance listed below that applies to vehicle (E70 or E90) and the scope of work performed.

| | | |
|-------------------------|--|--|
| Defect Code: | 00 18 37 01 00 | |
| | | |
| Labor Operation: | Labor Allowance: | Description: |
| 00 60 105 | Refer to KSD2 or E70 – 12 FRU/E90 - 12 | Check the emission monitoring components and program the control units without CAS (includes a vehicle test and charging the battery) |
| | | |
| 00 60 106 | Refer to KSD2 or E70 – 13 FRU/E90 – 13 FRU | Check the emission monitoring components and program the control units with CAS (includes a vehicle test and charging the battery) |
| | | |
| 00 60 107 | Refer to KSD2 or E70 – 21 FRU/E90 – 22 FRU | Check the emission monitoring components, replace the SCR mixer and EGR valve, and program the control units without CAS (includes a vehicle test and charging the battery) |
| | | |
| 00 60 108 | Refer to KSD2 or E70 – 22 FRU/E90 – 23 FRU | Check the emission monitoring components, replace the SCR mixer and EGR valve, and program the control units with CAS (includes a vehicle test and charging the battery) |
| | | |
| 00 60 109 | Refer to KSD2 or E70 – 14 FRU/E90 – 16 FRU | Check the emission monitoring components, replace the SCR mixer and program the control units without CAS (includes a vehicle test and charging the battery) |
| | | |
| 00 60 110 | Refer to KSD2 or E70 – 15 FRU/E90 – 17 FRU | Check the emission monitoring components, replace the SCR mixer, and program the control units with CAS (includes a vehicle test and charging the battery) |
| | | |
| 00 60 111 | Refer to KSD2 or E70 – | Check the emission monitoring components, replace the EGR valve and program the control units without CAS |

| | | |
|-----------|--|--|
| | 19 FRU/E90 – 18 FRU | (includes a vehicle test and charging the battery) |
| | | |
| 00 60 112 | Refer to KSD2 or E70 – 21 FRU/E90 – 19 FRU | Check the emission monitoring components, replace the EGR valve and program the control units with CAS (includes a vehicle test and charging the battery) |

All the labor operation codes listed above are Main labor operations.

If a control module fails to program correctly or initializations are required, the additional work must be claimed with separate labor operations under the defect code listed above; refer to KSD2.

ATTACHMENTS

View PDF attachment [B180512 Customer Letter](#).

[Copyright ©2013 BMW of North America, Inc.]