

> Constellation  
Heritage  
> 4700 Models

> 4800 Models  
> 4900 Models

> 5900 Models  
> 6900 Models

**Western Star  
Service Bulletin**

## General Information

Western Star front and drive axle alignment specifications are consistent with Technology and Maintenance Council (TMC) Recommended Practice 642B. When checking or adjusting axle alignment with Hunter or Bee Line equipment, use the measurements given in this bulletin. For more information and manual procedures, reference **Section 33.00** (front axle) and **Section 35.00** (rear axle) in the *Western Star Workshop Manual*.

**IMPORTANT:** For vehicle alignment to be accurate, the shop floor must be level in every direction. The turn plates for the front wheels must rotate freely without friction, and the alignment equipment must be calibrated every three months by a qualified technician from the equipment manufacturer. Western Star dealers must have proof of this calibration history.

**IMPORTANT:** Before starting axle alignment procedures on a vehicle equipped with an AirLiner® rear suspension, check the ride height and make any necessary adjustments until it is within specification. See **Group 32** in the *Western Star Workshop Manual*.

**NOTE:** For optimum tire life, it is recommended that an all-axle alignment be done by a qualified service provider between 15,000 and 30,000 miles (24 140 and 48 280 km), but no later than 90 days after a vehicle is put into service.

## Rear Axle Alignment

### Thrust ("from Perpendicular")

Ideally, each axle is perpendicular to the vehicle centerline. The "thrust" of an axle refers to its actual orientation in relation to the centerline. See [Fig. 1](#) and [Fig. 2](#). Note that in some cases, this measurement may be referred to as "from perpendicular". For target and limit measurements, see [Table 1](#) and [Table 2](#).

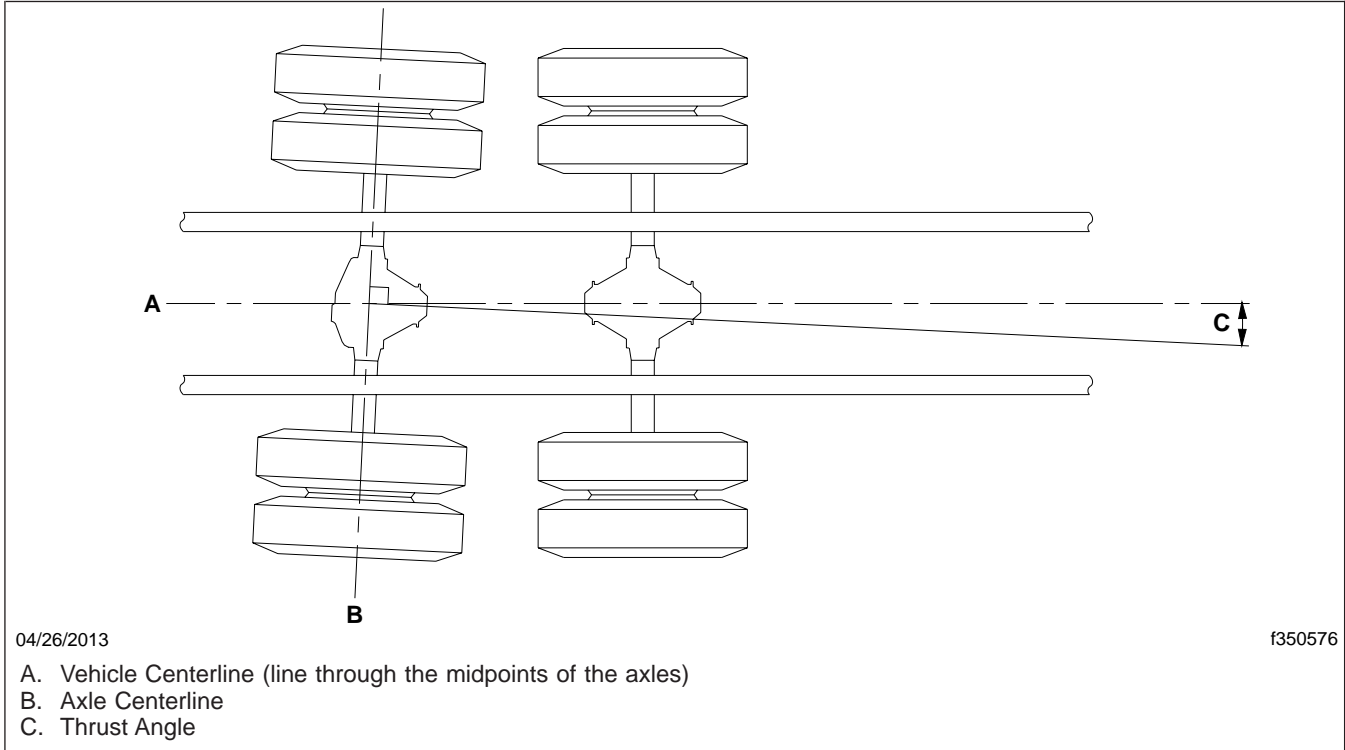

**Fig. 1, Thrust Angle, Measured With Hunter Equipment**

Thrust, Measured with Hunter Equipment		
Method	Target: degrees	Limit: degrees
Hunter*	0.00	±0.18

\* To use Hunter alignment equipment, refer to the applicable Hunter service literature.

**Table 1, Thrust, Measured with Hunter Equipment**

> Constellation  
Heritage  
> 4700 Models

> 4800 Models  
> 4900 Models

> 5900 Models  
> 6900 Models

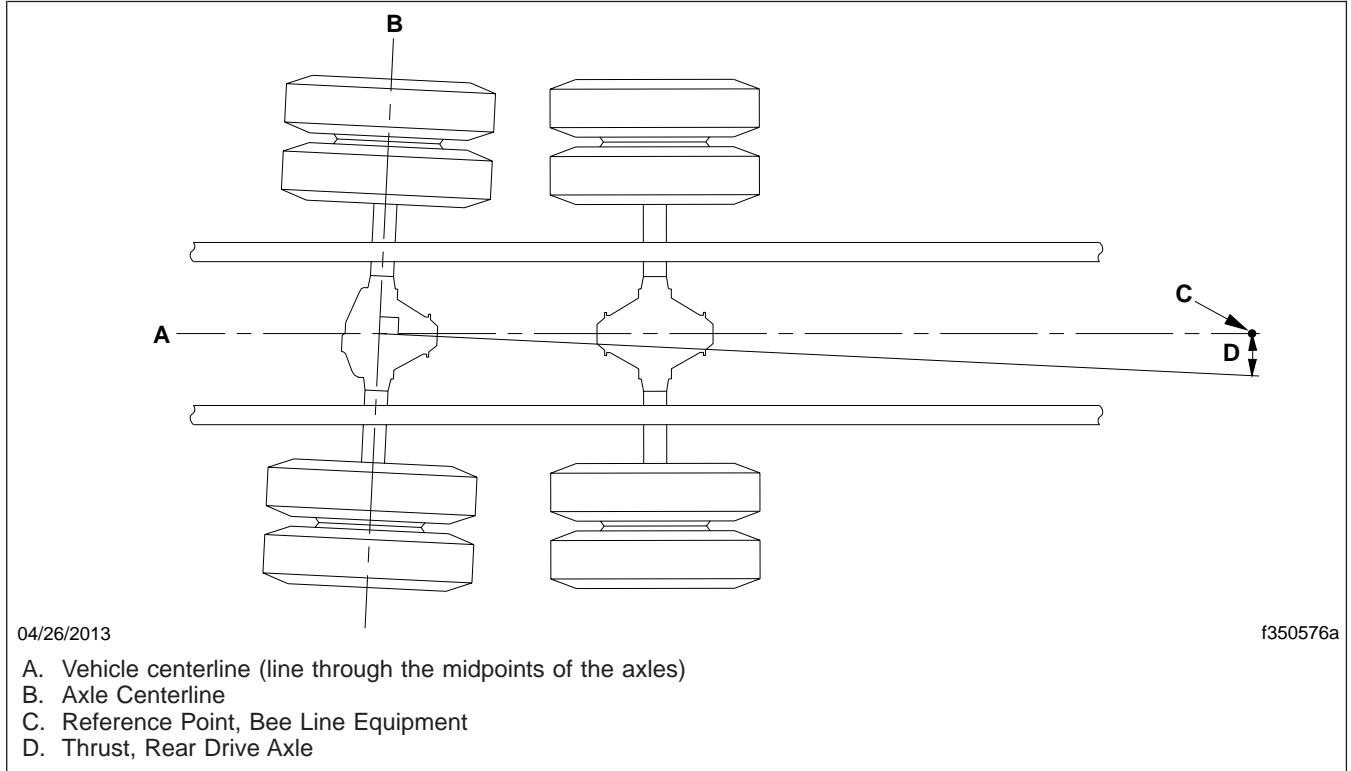

**Fig. 2, Thrust Measurement, Bee Line Equipment**

Thrust, Measured with Bee Line Equipment			
Method	Distance to Reference Point from Axle: inches (mm)	Target: inch (mm)	Limit ±: inch (mm)
Bee Line	90–110 (2286–2794)	0.0 (0.0)	5/16 (8)
	110–130 (2794–3302)		3/8 (10)
	130–150 (3302–3810)		7/16 (11)
	150–170 (3810–4318)		1/2 (13)
	170–190 (4318–4826)		9/16 (14)
	190–210 (4826–5334)		5/8 (16)
	210–230 (5334–5842)		11/16 (17)
	230–250 (5842–6350)		3/4 (19)
	250–270 (6350–6858)		13/16 (21)

**Table 2, Thrust, Measured with Bee Line Equipment**

## Scrub ("Parallelism")

Ideally, the two axles of a tandem are parallel to one another. The "scrub" (or parallelism) of the axles refers to a deviation from parallel. See [Fig. 3](#) and [Fig. 4](#). Scrub causes the axles to work against each other. For target and limit measurements, see [Table 3](#) and [Table 5](#).

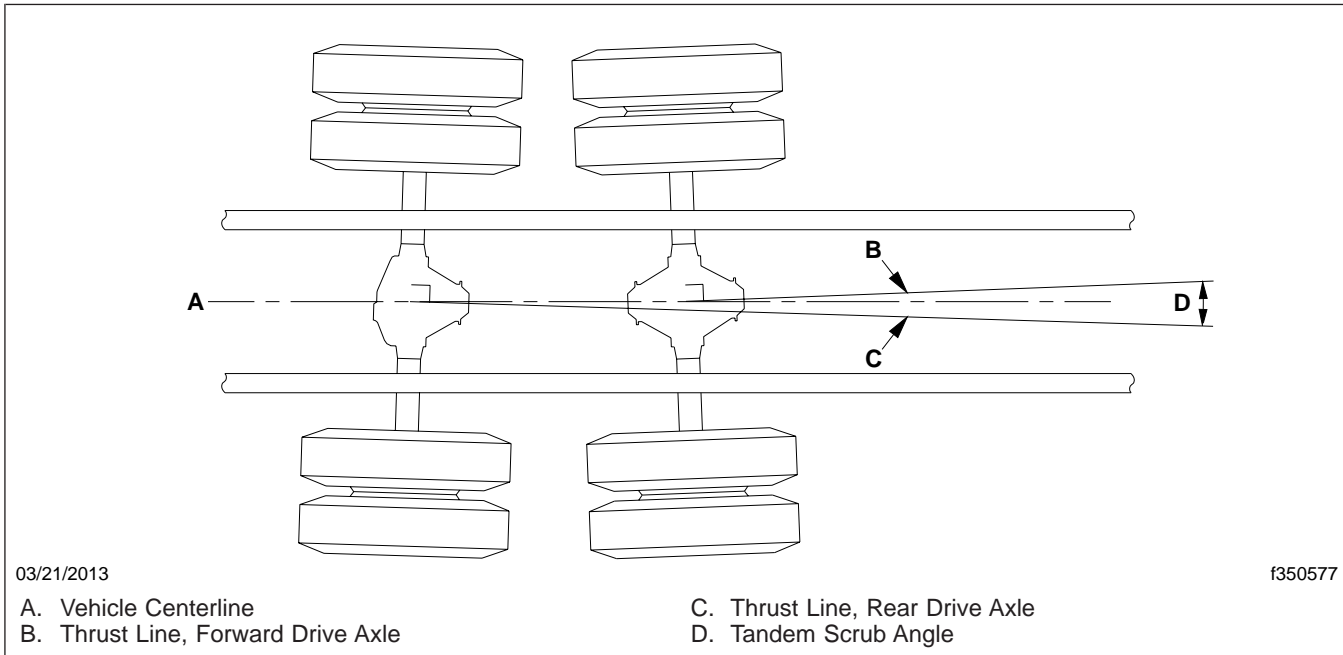

**Fig. 3, Tandem Scrub, Measured With Hunter Equipment**

Tandem Axle Scrub, Measured with Hunter Equipment		
Method	Target	Maximum Tolerance
Hunter	0.00 axle-to-axle difference.	±0.08 degree axle-to-axle difference; reference "D" in <a href="#">Fig. 3</a> .

**Table 3, Tandem Axle Scrub, Measured with Hunter Equipment**

> Constellation  
Heritage  
> 4700 Models

> 4800 Models  
> 4900 Models

> 5900 Models  
> 6900 Models

**Western Star  
Service Bulletin**

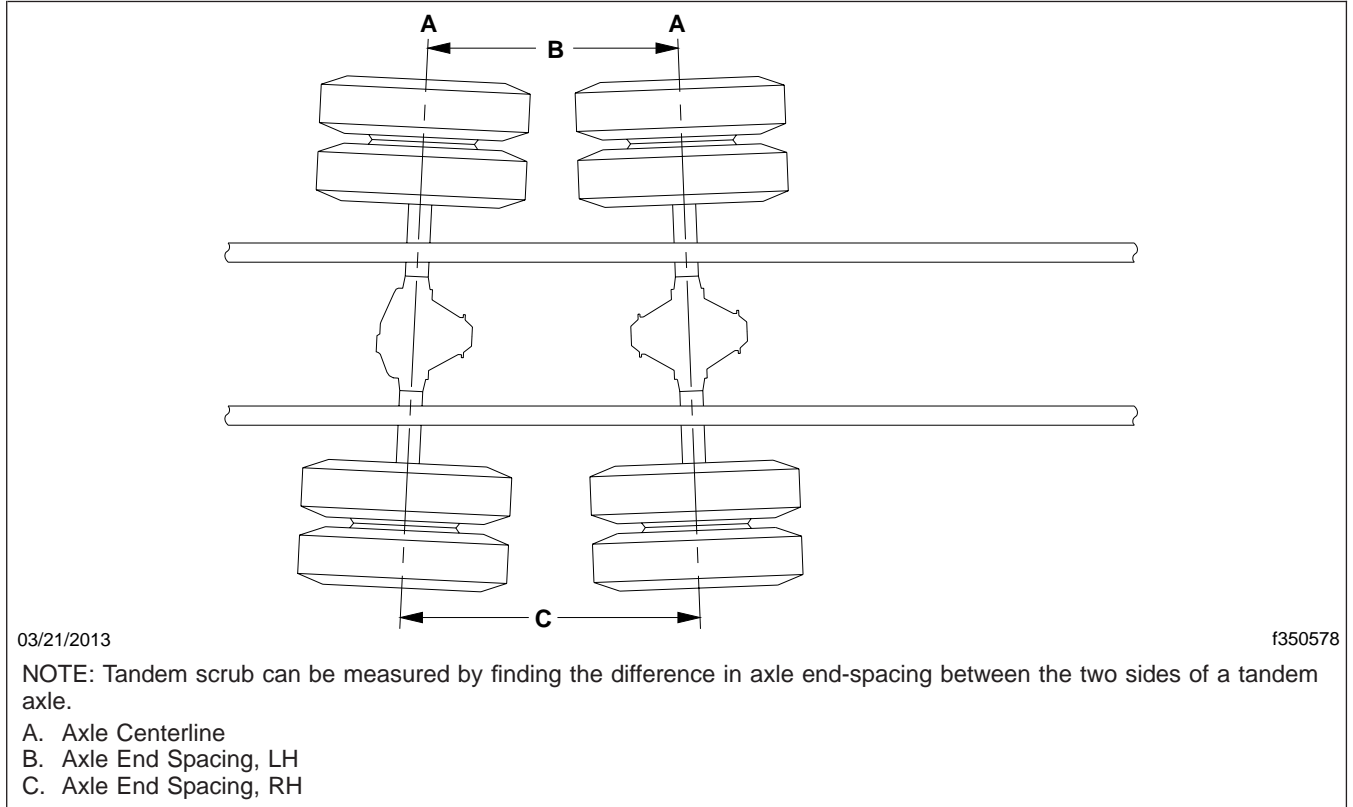

**Fig. 4, Tandem Scrub, Measured With Bee Line Equipment**

Tandem Axle Scrub, Measured with Bee Line Equipment		
Method	Target	Maximum Tolerance
Bee Line	0.0 (0.0)	±1/8 inch difference in axle end-spacing; reference "C" minus "B" in <a href="#">Fig. 4</a> .

**Table 4, Tandem Axle Scrub, Measured with Bee Line Equipment**

## Lateral Offset

Ideally, the vehicle centerline crosses the midpoint of all axles. "Lateral offset" refers to a deviation in the distance from the centerline to the wheel. See [Fig. 5](#). For target and limit measurements, see [Table 5](#).

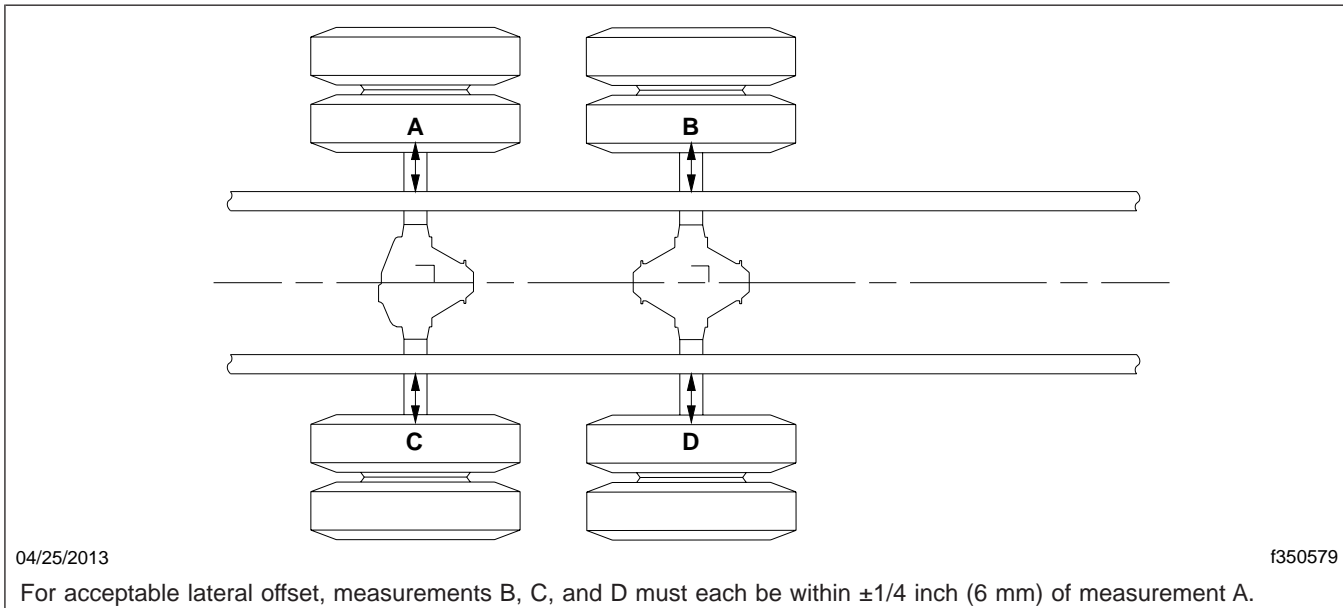

**Fig. 5, Lateral Offset Measurements**

Lateral Offset, Target and Limit	
Target: inch (mm)	Limits: inch (mm)
0.0 (0.0)	$\pm 1/4$ ( $\pm 6$ )

**Table 5, Lateral Offset, Target and Limit**

> Constellation  
Heritage  
> 4700 Models

> 4800 Models  
> 4900 Models

> 5900 Models  
> 6900 Models

**Western Star  
Service Bulletin**

## Steer Axle Alignment

### Toe-In

Wheel toe-in is the distance that the front of the wheels are closer together than the rear of the wheels as viewed from above. See [Fig. 6](#). For target and limit measurements, see [Table 6](#) and [Table 7](#).

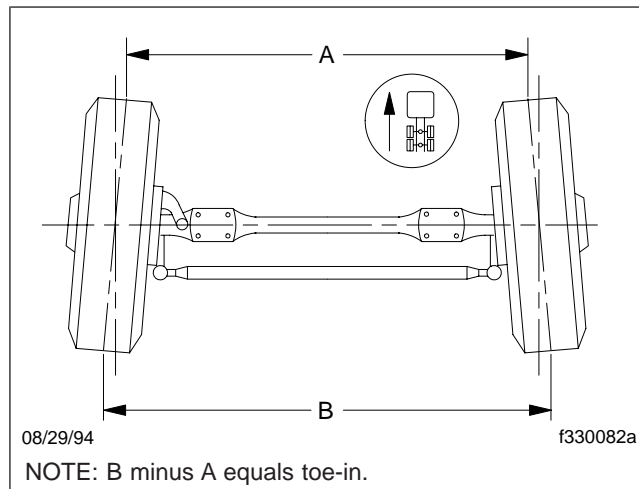

**Fig. 6, Wheel Toe-In (overhead view)**

Toe-In, Measured with Hunter Equipment	
Target: degrees	Limits: degrees
+0.09	0.00 to +0.18

**Table 6, Toe-In, Measured with Hunter Equipment**

Toe-In, Measured with Bee Line Equipment	
Target: in (mm)	Limits: in (mm)
+1/16 (+1.6)	0 to +1/8* (0 to +3.2)

\* If adjustment is required, set the toe-in as close as possible to +1/16 inch (+1.6 mm).

**Table 7, Toe-In, Measured with Bee Line Equipment**

## Caster

Caster angle is the tilt of the knuckle pin (or kingpin) as viewed from the side. Caster angle is measured in degrees and is adjustable. A positive caster angle is the tilt of the top of the knuckle pin toward the rear of the vehicle. A negative caster angle is the tilt of the top of the knuckle pin toward the front of the vehicle. Caster angles are based on the design load of the vehicle. See **Fig. 7**. For target and limit measurements, see **Table 8**.

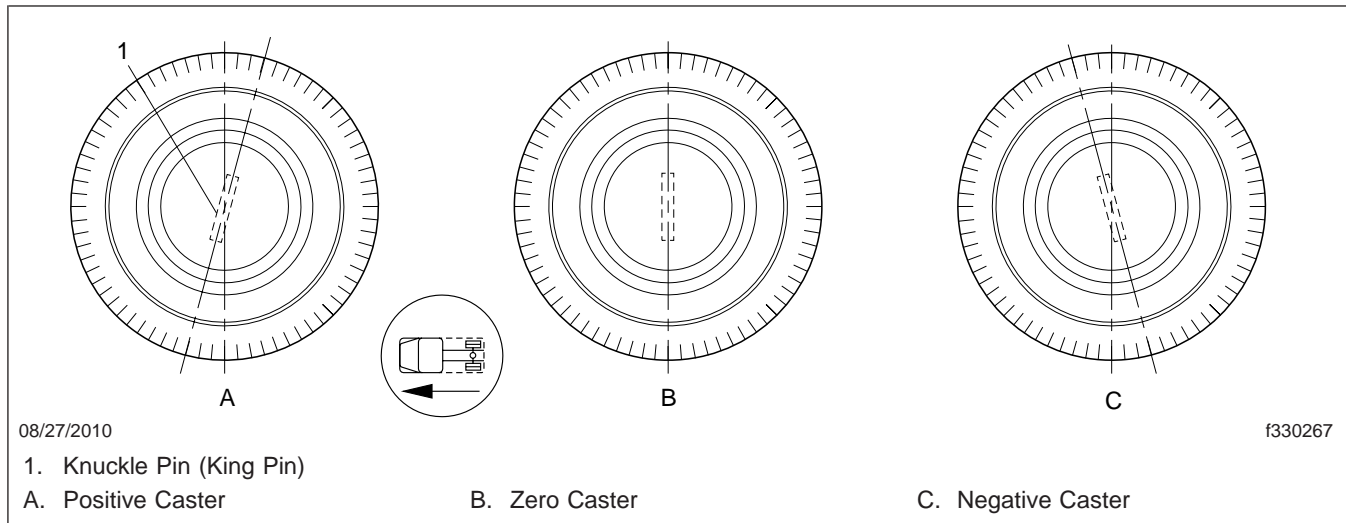

**Fig. 7, Caster Angle**

Caster Target and Limits			
Target (All Models): degrees	Limits, Hunter Equipment: degrees	Limits, Bee Line Equipment	
		Except LC 4000: degrees	LC 4000: degrees
+3-1/2	+2 to +5	+3 to +6-1/2	+2-1/4 to +4-3/4

IMPORTANT: Caster settings for the left and right sides *must* be within 1/2 degree of each other. It is necessary for only one side to be within the specifications given in this table.

**Table 8, Caster Target and Limits**

## Warranty

This bulletin is informational only. Warranty does not apply.