

1 5 20-13



Service Information Bulletin

| SUBJECT | DATE |
|----------------|----------|
| Cylinder Block | May 2013 |

Additions, Revisions, or Updates

| Publication Number / Title | Platform | Section Title | Change |
|----------------------------|-------------|--|------------------------|
| DDC-SVC-MAN-0081 | DD Platform | Removal of the GHG14 DD15AT gear case front cover | This is a new section. |
| | | Installation of the GHG14 DD15AT gear case front cover | |



13400 Outer Drive, West, Detroit, Michigan 48239-4001
 Telephone: 313-592-5000
www.demanddetroit.com

2 Removal of the gear case front cover

Remove as follows:

NOTICE: Do not allow dirt or debris to fall into the gear train as damage can occur.

1. Clean the area surrounding the gear case front cover.
2. Remove the three mounting bolts (1) on the front of the gear case cover (2).

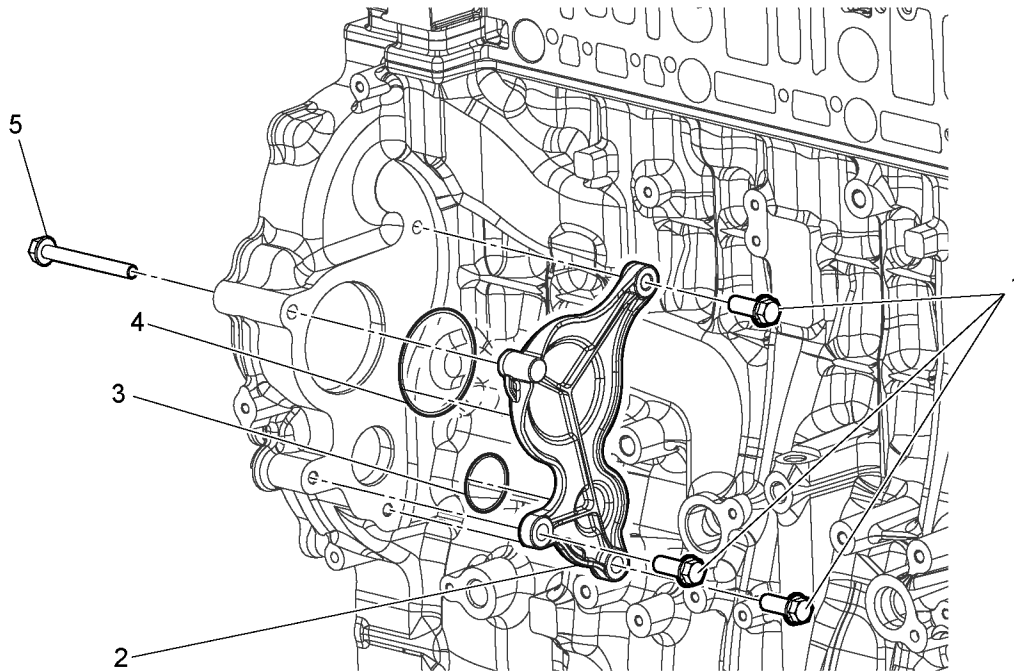

d090098

3. Remove the bolt (5) holding the gear case cover from the rear of the engine.
4. Remove the gear case cover (2) and discard the O-rings (3, 4).

3 Installation of the gear case front cover

Install as follows:

NOTICE: Do not allow dirt or debris to fall into the gear train as damage can occur.

1. Install new O-rings rings (3, 4) onto the gear case cover (2).

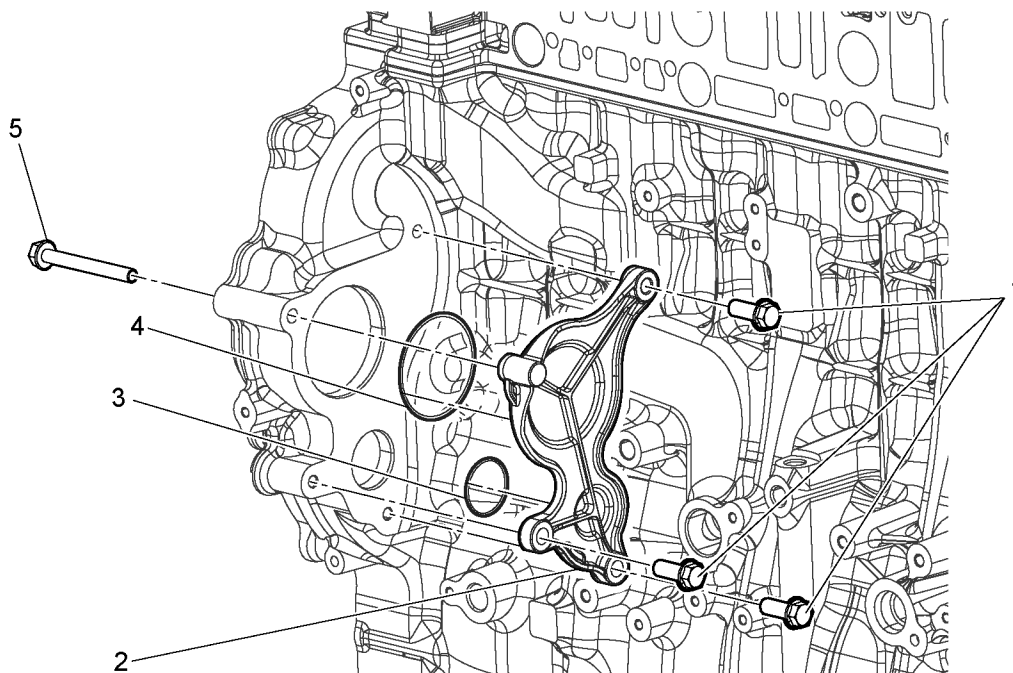

d090098

2. Using clean engine oil, lightly lubricate the O-rings.
3. Install the gear case cover (2) onto the engine with 4 bolts.
4. Torque the bolts to 60 N•m (44 lb•ft).