

FLA COE
FLB COE
FLD Conventional
Business Class
FLC 112 Conventional

Century Class Conventional
Argosy COE
Cargo
Columbia

Coronado
Business Class M2
> Cascadia
108SD/114SD

Freightliner
Service Bulletin

Description of Revisions: *This bulletin replaces the version dated December 2012. The list of symptoms and troubleshooting diagnostics have been revised.*

General Information

Cascadia vehicles equipped with Eaton manual transmissions may experience no-start faults that are associated with the clutch position combination switch (clutch control switch). Recent investigations have exposed two possible causes, and this bulletin should be used to determine the cause of the problem. Use the procedure in this bulletin, and service information published on www.AccessFreightliner.com and www.RoadRanger.com, to diagnose and repair the problem, if the following symptoms are present:

- engine not starting
- engine has trouble starting/is hard to start
- transmission grinding going into starting gear
- excessive clutch brake wear
- early clutch brake squeeze
- clutch pedal not returning after it has been pressed

The listed symptoms can be caused by one of the following:

- **Clutch Over-Adjust:** It is possible that Eaton clutch pressure plates can become over-adjusted in normal service. In the most severe cases, the clutch brake will contact the release bearing before the pedal will close the "clutch open" switch.
- **Clutch Position Combination Switch:** Deposits can accumulate on the contacts of the clutch position combination switch, causing high resistance.

Diagnostics

Follow the steps below to identify the failed part.

1. Park the vehicle on a level surface, shut down the engine, and set the parking brake. Chock the tires.
2. Make sure the batteries are charged. Turn the ignition key ON.
3. Connect the vehicle to the ServiceLink diagnostic tool. Select the SAM Cab ECU, then go to the "Templates" tab and select "Starter Relay, Crank Enable." See [Fig. 1](#).
4. While pushing the pedal to the point of clutch brake squeeze ([Fig. 2](#)), check the SAM Cab Template. Does the actuation of the pedal switch register? The actuation of the pedal is registered when the "Bottom of Clutch Circuit" indicator turns green and reads "At Bottom," as shown in [Fig. 3](#).

If NO, go to the next step.

If YES, the system is not experiencing any of the failures covered in this bulletin. Discontinue the use of this Service Bulletin and continue with normal diagnostics for the rest of the starting system; see *Cascadia Troubleshooting Manual*, **P01.01—Starting and Charging**.

Freightliner Service Bulletin

FLA COE
 FLB COE
 FLD Conventional
 Business Class
 FLC 112 Conventional

Century Class Conventional
 Argosy COE
 Cargo
 Columbia

Coronado
 Business Class M2
 > Cascadia
 108SD/114SD

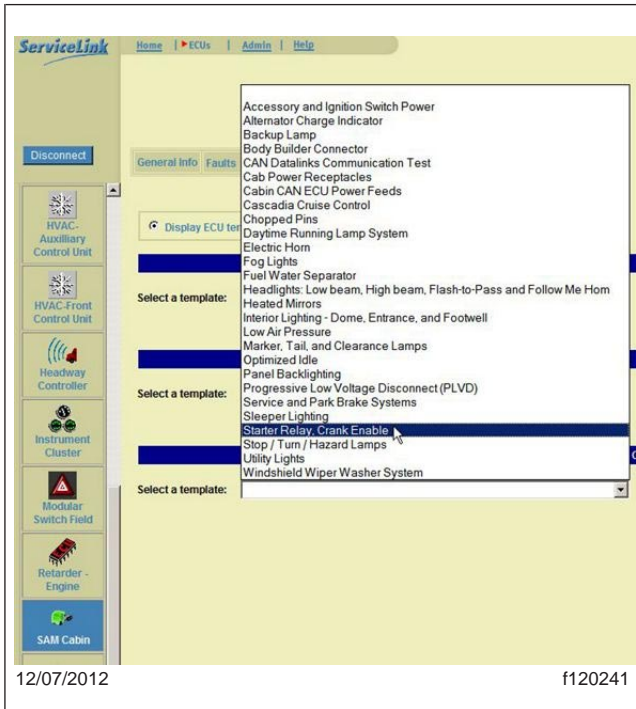

Fig. 1, ServiceLink Template Menu

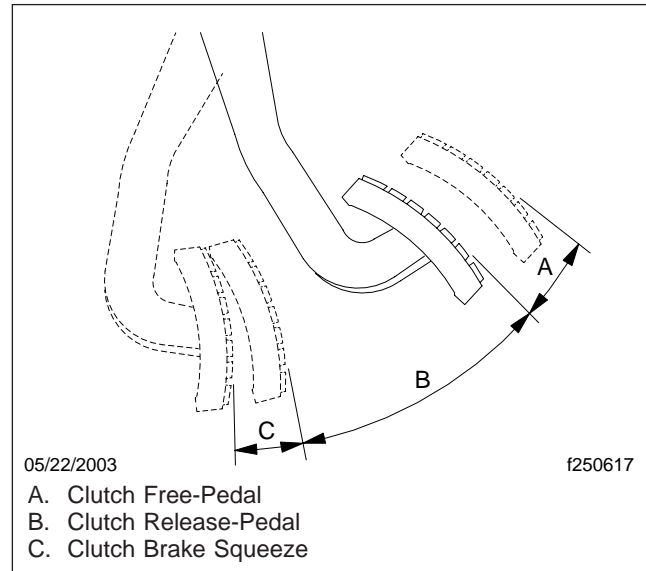

Fig. 2, Clutch Pedal Movement

5. Continue to monitor the SAM Cab ECU while having an assistant open the bleed valve on the slave cylinder (see Fig. 4), allowing the pedal to travel all the way to the floor. Have the assistant close the valve. Does the actuation of the pedal switch register on the "Bottom of Clutch Circuit" indicator? If necessary, top off fluid with DOT 4 brake fluid.

If NO, the actuation of the pedal does not register, go to the next step.

If YES, the actuation of the pedal registers, go to step 8.

6. Disconnect the chassis harness from the clutch position combination switch. See Fig. 5.
7. Use a jumper wire to close the clutch low position control circuit on the chassis side (between pins A and C in Table 1), and look for a response on the SAM Cab ECU template. Does the response register on the template?

If YES, replace the switch with the newer version that is marked with a yellow dot, indicating the seal has been removed. See Cascadia Workshop Manual, Section 25.01, Subject 150.

If NO, the system is not experiencing any of the failures covered in this bulletin. Discontinue the use of this Service Bulletin and begin using the standard diagnostics for the specific symptoms experienced.

FLA COE
 FLB COE
 FLD Conventional
 Business Class
 FLC 112 Conventional

Century Class Conventional
 Argosy COE
 Cargo
 Columbia

Coronado
 Business Class M2
 > Cascadia
 108SD/114SD

Freightliner
 Service Bulletin

Starter Relay, Crank Enable
 TEMPLATE VER. 5.3, 03/06/2012

APPLIES TO:
 Cascadia 6.0, 6.2

View
 Fault
 Codes

Click on the **i** button in the upper tool bar for additional information.

Wiring diagrams in module 156

IGN Switch CAN Message

Ignition

IGN Switch Circuits

ACC OFF IGN Crank

X13-5 X13-4 X13-6 X13-1

WAIT 30 SECONDS
 between starting attempts to allow the starter protection software to release inhibit. This inhibit is for starter overheating protection.

Key

- ! Temporary loss of communication
- Inputs & interlocks have been met
- Outputs are active
- Missing input

Battery Voltage

Battery Voltage (SAM_CAB) 12.10

Engine RPM

Engine RPM (SAM_CAB) 0

NEUTRAL INPUTS

At least one neutral input must be green to allow cranking. Confirm with SAM cab and SAM chassis parameter configuration.

Bottom of Clutch Circuit

Bottom of Clutch SAM Cab
 Connector X11 Pins 16 and 20

Manual Trans Neutral Sw

Signal Not Available
 Neutral Switch Status
 Message From SAM Chassis

Auto Trans Crank Enable

Signal Not Available
 Auto Trans Neutral Status
 Rebroadcast From SAM Cab

Neutral Switch Circuit

Signal Not Available
 Neutral Switch - SAM Chassis
 Connector X59 Pins 2 and 18

DECISIONS

Green when active.

Starter Relay Inhibit

Not Inhibited

Crank Interlock

Crank Inhibit

Connector X13, Pin 14
 When a parameter with CI is set, this must be green to crank.

OUTPUTS

Output is active when yellow.

Starter Relay Output Circuit

OFF
 Starter Relay - SAM Cab
 Connector X19, Pin3

Ether Start

OFF

12/07/2012 f120242

NOTE: Cascadia SAM versions 6.0 and 6.2 template shown. Version 5.4 template is similar. Shown with "Bottom of Clutch Circuit" indicator (circled) registering pedal actuation.

Fig. 3, "Starter Relay, Crank Enable" Template

Freightliner Service Bulletin, September 2013

Page 3

Freightliner Service Bulletin

FLA COE
FLB COE
FLD Conventional
Business Class
FLC 112 Conventional

Century Class Conventional
Argosy COE
Cargo
Columbia

Coronado
Business Class M2
> Cascadia
108SD/114SD

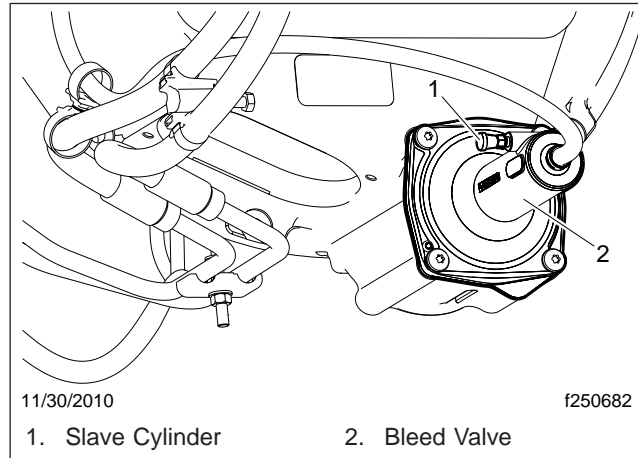

Fig. 4, Slave Cylinder Bleed Valve

Connector	Clutch Position Combination Switch Diagram	A	B	C
<p>03/19/2007 f545004</p>	<p>03/19/2007 f545006</p>	Blue	—	Black

Table 1, Clutch Position Combination Switch, Bottom of Clutch Control

8. Remove the clutch inspection cover.
9. Using a telescoping bore gauge, measure the gap between the clutch brake and the release bearing, then measure the gauge with a digital caliper. The distance should be more than 0.48 inch (12 mm). See [Fig. 6](#).

If the distance is correct, install the inspection cover. Tighten the screws 14 to 18 lbf-ft (19 to 24 N·m). Replace the hydraulic pedal assembly. See *Cascadia Workshop Manual*, **Section 25.01**.

If the distance is less than 0.48 inch (12 mm), reset the clutch (see “Resetting the Clutch”).

Resetting the Clutch

1. With the parking brake applied and the tires chocked, have an assistant hold the clutch pedal down.
2. With the pedal held down, move the wear indicator tab to the left (NEW) position. See [Fig. 7](#).

FLA COE
 FLB COE
 FLD Conventional
 Business Class
 FLC 112 Conventional

Century Class Conventional
 Argosy COE
 Cargo
 Columbia

Coronado
 Business Class M2
 > Cascadia
 108SD/114SD

**Freightliner
 Service Bulletin**

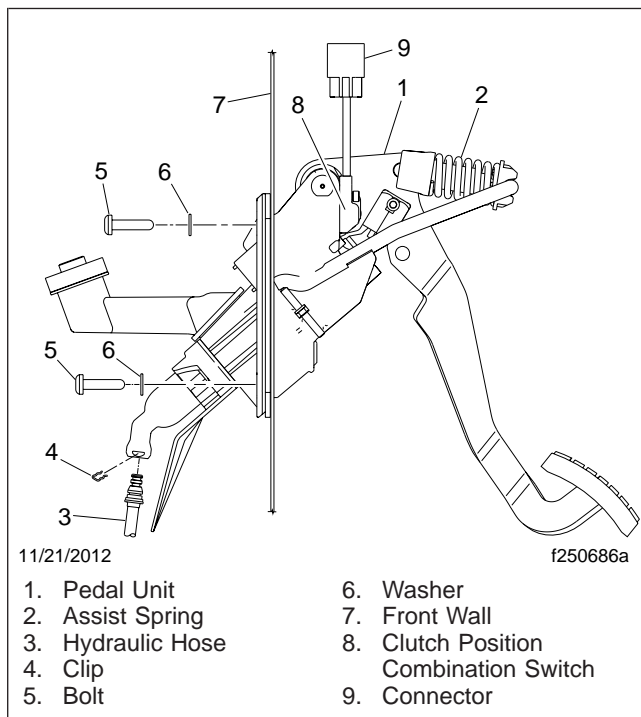

Fig. 5, Clutch Pedal Assembly

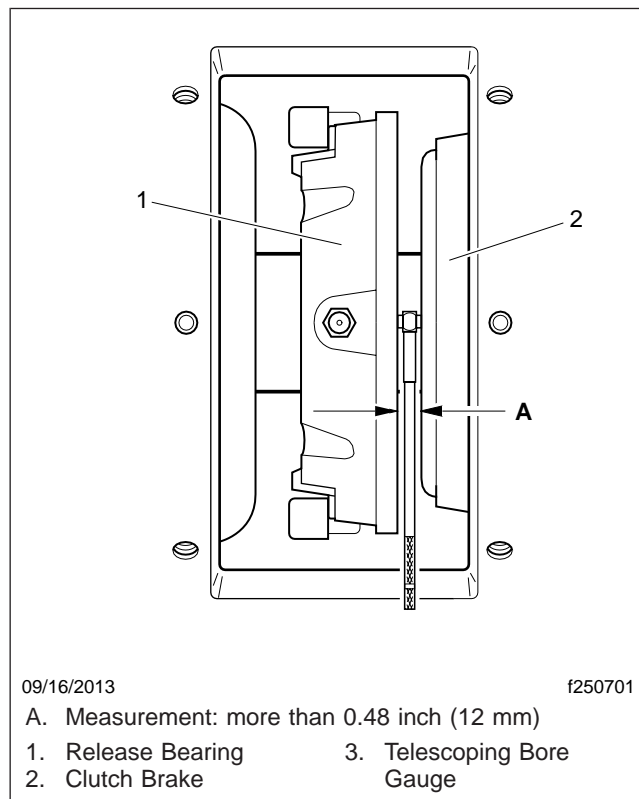

Fig. 6, Clutch Gap

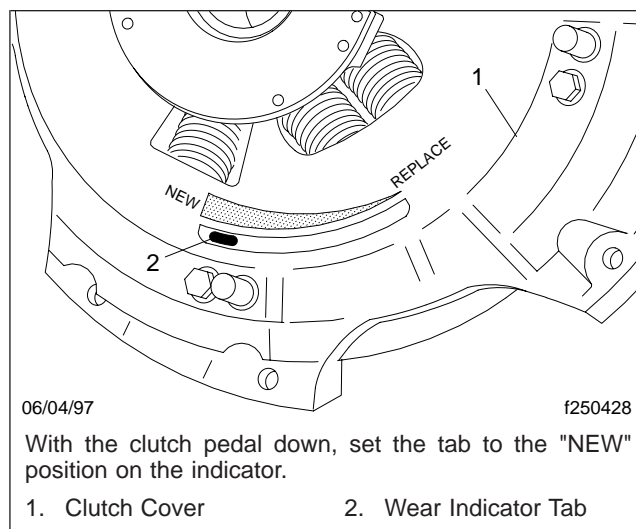

Fig. 7, Resetting the Wear Indicator Tab

Freightliner Service Bulletin

FLA COE
FLB COE
FLD Conventional
Business Class
FLC 112 Conventional

Century Class Conventional
Argosy COE
Cargo
Columbia

Coronado
Business Class M2
> Cascadia
108SD/114SD

3. If the cam moves, hold the adjustment tab in the new position, release the pedal, and go to step 7. If the cam does not move, support the transmission and remove the clutch housing bolts. Install 1/2-inch spacers between the clutch housing and the flywheel housing, then, with the clutch pedal held down, attempt to reset the wear indicator tab again.
4. Remove the spacers, then install the clutch housing bolts. Tighten the bolts 43 to 53 lbf-ft (58 to 72 N·m) for Patch-Lok capscrews, or 38 to 45 lbf-ft (52 to 61 N·m) for non-locking capscrews with lockwashers.

IMPORTANT: To prevent the clutch from returning to an over-adjusted position, the gaps between the sleeves and pins have to be eliminated, as detailed below.

5. Install four shipping bolts (7/16-14 x 1-3/4 UNC) next to the sleeves and pins, as shown in **Fig. 8**. Tighten the bolts so that the gaps between the sleeves and pins are eliminated.

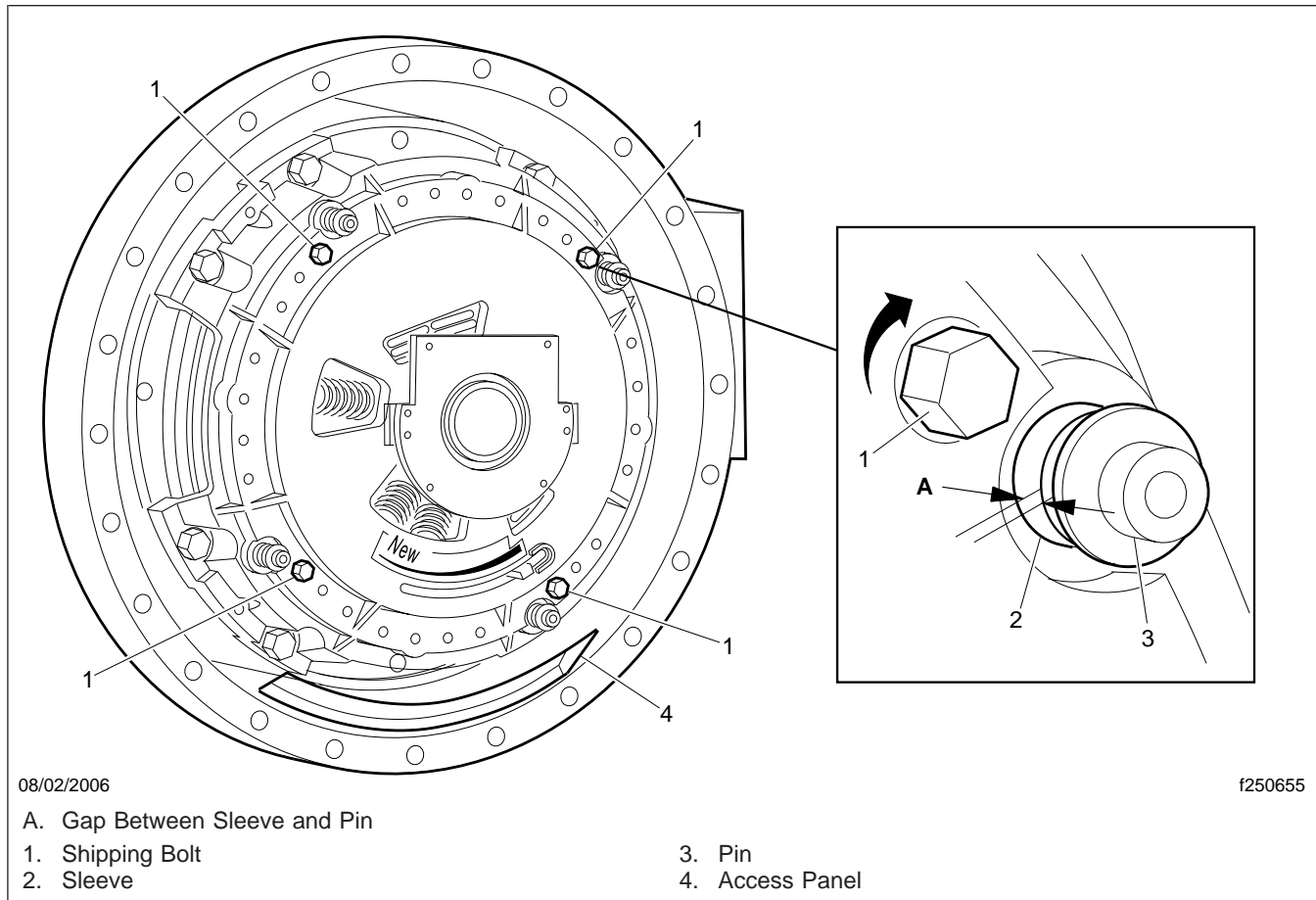

Fig. 8, Removing the Gap Between Sleeve and Pin

6. Remove the shipping bolts.
7. Push the clutch pedal down and squeeze the clutch brake five times to reposition the bearing, then recheck the gap between the clutch brake and the release bearing. Does the gap return to less than 0.48 inch (12 mm)?

FLA COE
FLB COE
FLD Conventional
Business Class
FLC 112 Conventional

Century Class Conventional
Argosy COE
Cargo
Columbia

Coronado
Business Class M2
> Cascadia
108SD/114SD

**Freightliner
Service Bulletin**

If NO, the gap is still greater than 0.48 inch (12 mm), replace the hydraulic pedal assembly. See *Cascadia Workshop Manual*, **Section 25.01**.

If YES, the gap returns to less than 0.48 inch (12 mm), replace the clutch assembly. Follow the clutch replacement instructions in the **Cascadia Workshop Manual**.

IMPORTANT: Before clutch replacement, the dealer/repair facility must call Eaton Warranty for pre-approval supported by a claim number (ETN). Ensure that four shipping bolts (7/16" x 1-3/4" UNC) are installed to cage the clutch before removal from the flywheel. Return the clutch to Eaton Clutch Division, with the claim number clearly marked on the outside of the box.

Warranty

Normal warranty applies.