

General Information

For vehicles equipped with ConMet PreSet® hubs, ConMet recommends replacing the bearing spacer with a new one whenever a hub is removed. See **Fig. 1**. Bearing spacers are available through PartsPro®.

To distinguish between a PreSet and PreSet Plus™ bearing spacer, check the ends of the spacer. PreSet Plus bearing spacers have undergone a heat-treating process that discolors the ends; see **Fig. 2**. This type of discoloration is normal for heat-treated spacers. PreSet bearing spacers have not been heat-treated.

NOTE: This bulletin does not apply to PreSet Plus hubs.

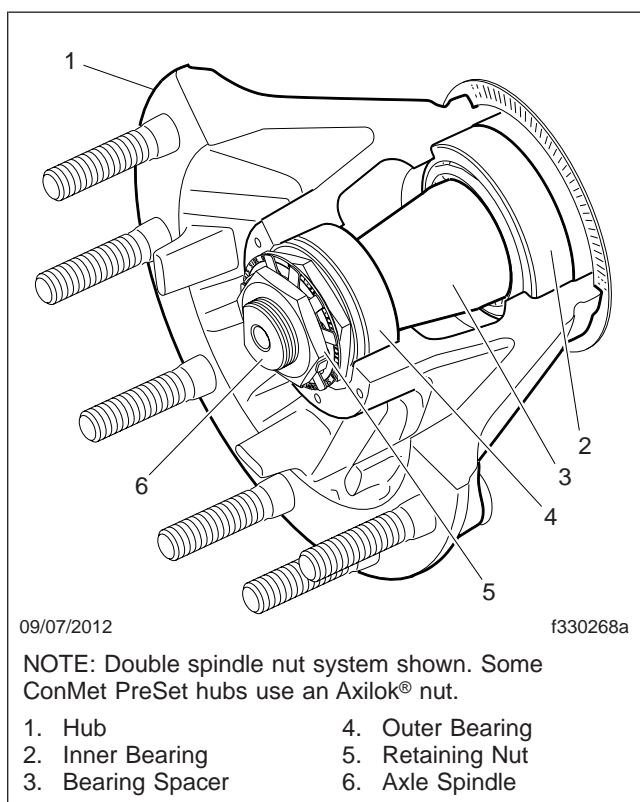

Fig. 1, ConMet PreSet Steer Hub, Cut-Away View

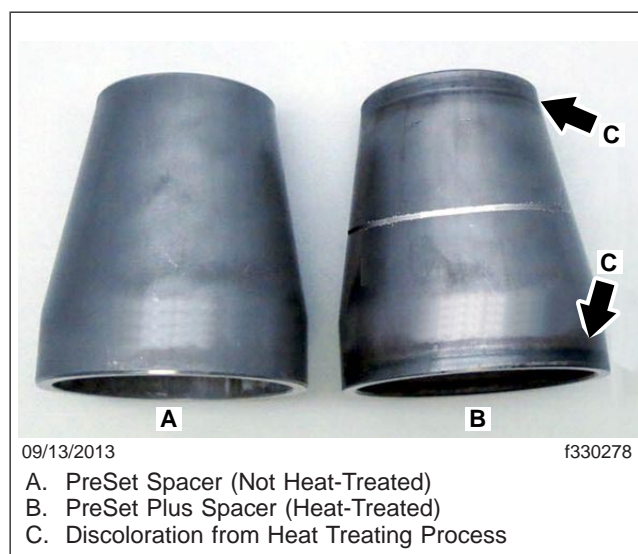

Fig. 2, PreSet and PreSet Plus Bearing Spacers

Warranty

This is an informational bulletin only. Warranty does not apply.