



**DETROIT**<sup>™</sup>  
DEMAND PERFORMANCE<sup>™</sup>

**18SP698 – EPA07/10 Three-Filter Fuel System DD15/16 High Pressure Fuel Feed Lines, Mounting Bracket, Vibration Dampers and P-clips Service Kit (P/N: A4720707932)**



 **WARNING:**

**PERSONAL INJURY**

All parts provided within this kit must be installed in the proper locations, and **MUST** be fastened to the specified torque. Failure to properly torque hardware/components will result in failure of a high pressure fuel feed line, resulting in possible fire and/or personal injury.

 **WARNING:**

**PERSONAL INJURY**

All parts provided with this kit are single-use items and cannot be reused. Reuse of hardware/component items may result in the failure of a high pressure fuel line, resulting in possible fire and/or personal injury.

## NOTICE:

Failure to follow these instructions will result in catastrophic damage to the engine and will not be covered under warranty.

### **KIT DESCRIPTION**

This service kit includes all necessary parts to replace the high pressure fuel feed lines, mounting bracket and vibration dampers in the event one of these parts are loosened, removed or missing from the engine.

### **KIT CONTENTS**

Service kit P/N: A4720707932 contains all of the necessary parts to replace the high pressure fuel feed lines on EPA07/10 DD15/16 engines.

Part No.	Qty.	Description
A4720780210	2	High pressure fuel feed line
A4720700240	2	Vibration damper
A4720700540	2	P-Clip
N000000007957	2	Bolt M6x12mm
N910105006023	3	Bolt M6x16mm
N910105008011	2	Bolt M8x20mm
A4720780341	1	Return line P-clip
A4720701040	1	Mounting bracket
18SP698	1	Installation Instructions

## Removal of the High Pressure Fuel Rail Feed Lines

Remove as follows:

### **WARNING:**

#### **PERSONAL INJURY**

**To prevent the escape of high pressure fuel that can penetrate skin, ensure the engine has been shut down for a minimum of 10 minutes before servicing any component within the high pressure circuit. Residual high pressure fuel may be present within the circuit.**

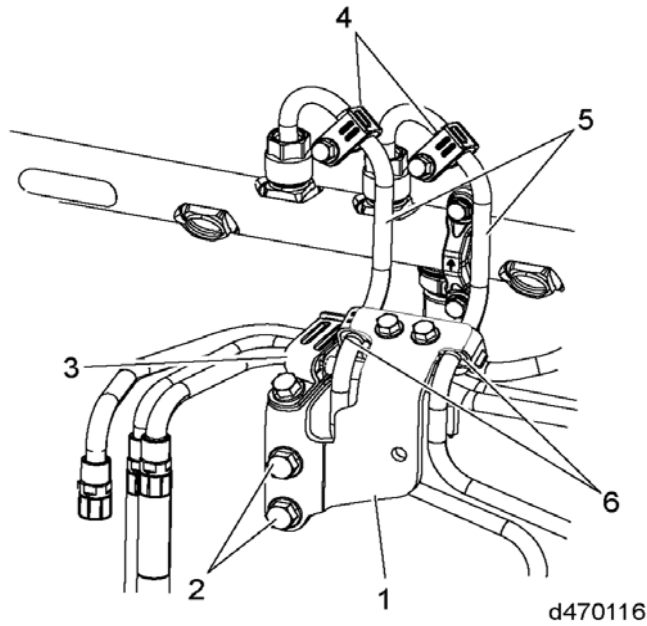

Engines with a serial number before 472901S0012796

Item	Component
1	Mounting bracket
2	Mounting bracket bolts
3	Return lines P-clip and bolt
4	Vibration dampers and bolts
5	High pressure fuel feed lines
6	Vibration dampers and bolts

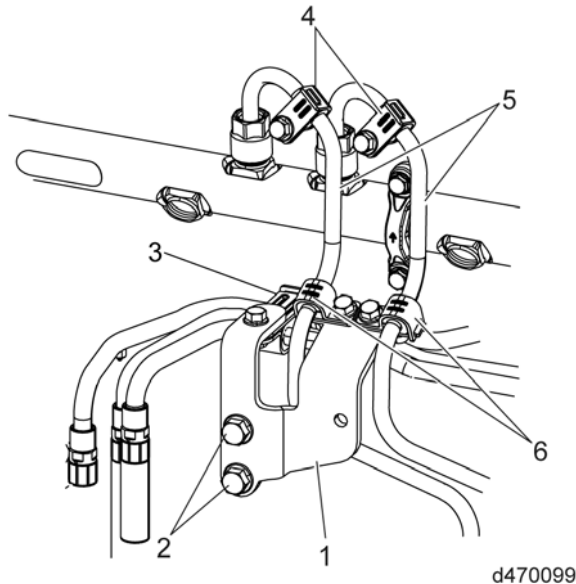

d470099

Engines with a serial number after 472901S0012796

Item	Component
1	Mounting bracket
2	Mounting bracket bolts
3	Return lines P-clip and bolt
4	Vibration dampers and bolts
5	High pressure fuel feed lines
6	Vibration dampers and bolts

1. Disconnect the batteries.
2. Remove and discard the return lines P-clip bolt from the mounting bracket.
3. Remove and discard the two bolts and vibration dampers (6) from the mounting bracket (1).
4. Remove and discard the mounting bracket bolts (2) from the intake manifold and discard the mounting bracket (1)

**NOTE:**

When using tool J-48770 to remove the high pressure pump rail feed lines, hold the high pressure pump fitting with a 24mm wrench.

5. Using tool J-48770, remove and discard the high pressure pump rail feed lines (5) and vibration dampers (4) from the fuel rail and high pressure fuel pump.
6. Remove and discard the return lines P-clip (3).

# Installation of the High Pressure Fuel Rail Feed Lines

Install as follows:

**NOTE:**

DO NOT install bolts and fittings using power tools. All bolts and fittings MUST be installed using hand tools.

 <b>WARNING:</b>
<b>PERSONAL INJURY</b>
<b>All parts provided within this kit must be installed in the proper locations, and MUST be fastened to the specified torque. Failure to properly torque hardware/components will result in failure of a high pressure fuel feed line, resulting in possible fire and/or personal injury.</b>

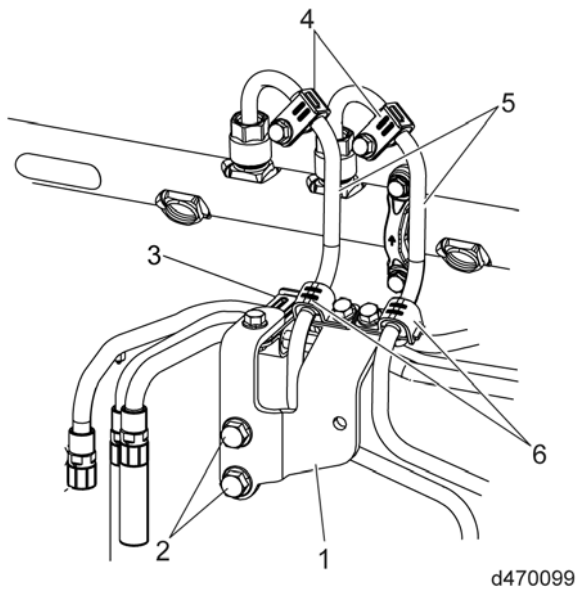

Item	Component	Part number
1	Mounting bracket	A4720701040
2	Mounting bracket bolts	N910105008011
3	Return lines P-clip and bolt	A4720780341 and N910105006023
4	Vibration dampers and bolts	A4720700240 and N910105006023
5	High pressure fuel feed lines	A4720780210
6	P-clips and bolts	A4720700540 and N000000007957

1. Install the new return lines P-clip (3) (P/N: A4720780341) on to the return lines.
2. Clean the sealing area inside the high pressure fuel pump fittings using a clean lint free cloth.

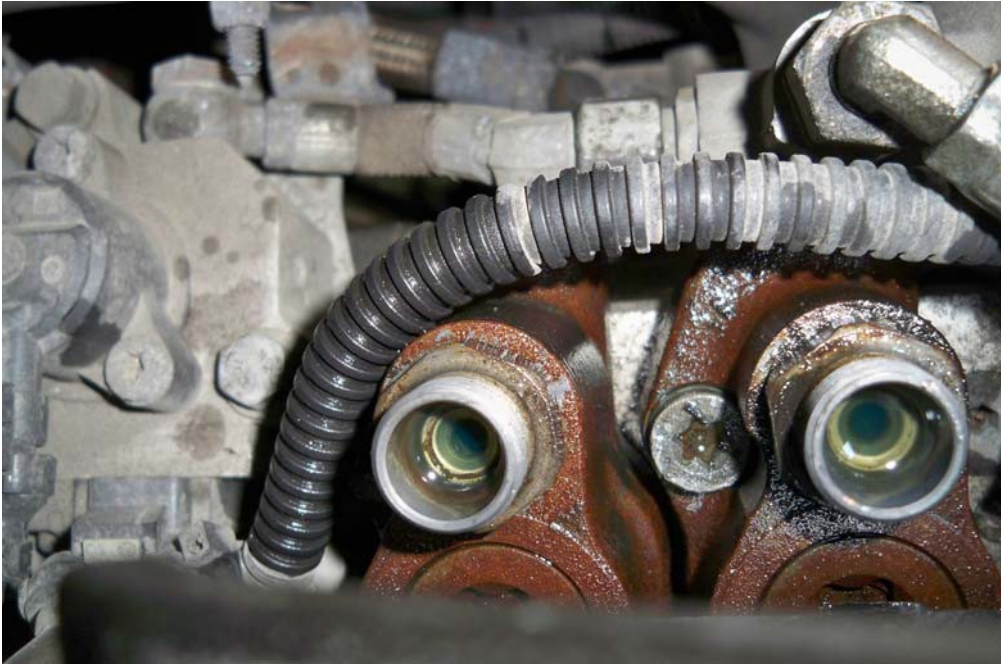

3. Clean the sealing area inside the high pressure fuel rail using a clean lint free cloth.



4. Install the rear high pressure fuel line (5) (P/N: A4720780210) to the fuel rail and the high pressure fuel pump. Hand tighten the nuts.
5. Using tool J-48770, torque the rear high pressure fuel line nuts to 40 N·m (30 lb·ft).

6. Install the front high pressure fuel line (5) (P/N: A4720780210) to the fuel rail and the high pressure fuel pump. Hand tighten the nuts.
7. Using tool J-48770, torque the front high pressure fuel line nuts to 40 N·m (30 lb·ft).
8. Install the new mounting bracket (1) (P/N: A4720701040) and two new mounting bracket bolts (2) (P/N: N910105008011) to the intake manifold. Torque to 30 N·m (22 lb·ft).

### NOTICE:

New P-clip/vibration dampers MUST be installed on to the high pressure fuel rail feed lines with the Lower P-clip Plate (1) inserted in to the P-clip/vibration damper window (2).

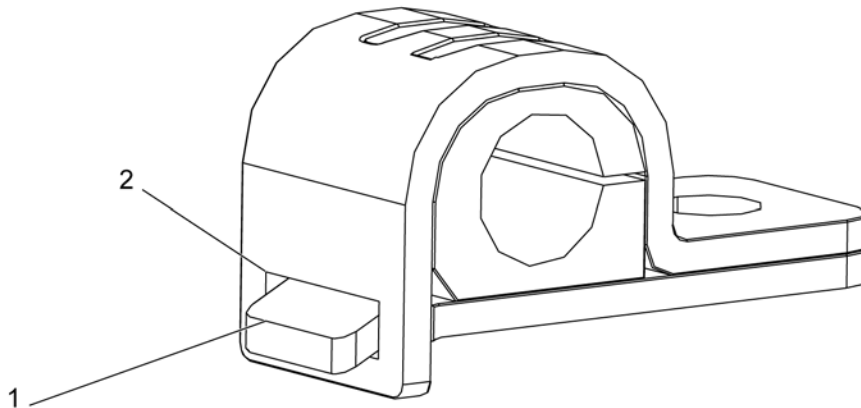

d470247

9. Install two new P-clips (6) (P/N: 4720700540) and two new bolts (P/N: N000000007957) on to the high pressure fuel rail feed lines (5) and the mounting bracket (1). Torque to 15 N·m (132 lb·in.).
10. Install two new vibration dampers (4) (P/N: A4720700240) and two new bolts (P/N: N910105006023) on to the high pressure fuel rail feed lines (5). (Refer to illustration for proper location of the vibration dampers). Torque to 15 N·m (132 lb·in.).
11. Install a new bolt (P/N: N910105006023) on to the return lines P-clip. Torque to 15 N·m (132 lb·in.).

### NOTICE:

DO NOT use the high pressure fuel rail feed lines without new P-clips, vibration dampers and bolts installed.

12. Connect the batteries.



**CAUTION:**

**ELECTRICAL SHOCK**

**To avoid injury from electrical shock, use care when connecting battery cables. The magnetic switch studs are at battery voltage.**

13. Prime the fuel system. [Refer to section "Priming of the Fuel System Using ESOC 350 Fuel Priming Pump."](#)
14. Perform the Rail Pressure Bleed-Off test to verify that there are no leaks. [Refer to section "Rail Pressure Bleed-Off Test Using DDDL \(EPA07\)."](#) [Refer to section "Fuel Injection System \(FIS\) Leak Detection \(EPA10\)."](#)
15. If there are leaks, find the leak and repair, as necessary.



13400 Outer Drive, West, Detroit, Michigan 48239-4001  
Telephone: 313-592-5000  
WWW.DEMANDETROIT.COM

---

Specifications are subject to change without notice. Detroit Diesel Corporation is registered to ISO 9001:2008. Copyright © Detroit Diesel Corporation. All rights reserved. Detroit™ is a brand of Detroit Diesel Corporation, a Daimler company.

**18SP698 1304** As technical advances continue, specifications will change. Printed in U.S.A.