



Service Bulletin

TECHNICAL

Subject: 60/40 Side Cargo Door Binds or Will Not Open (Install New Hinge Kit)

Models: 2001-2009 Chevrolet Express Vans
2001-2009 GMC Savana Vans
Equipped with 60/40 Side Cargo Doors (RPO E24 and E26)

This bulletin has been revised to update the Parts and Warranty Information. Please discard Corporate Bulletin Number 09-08-64-030.

Condition

Some customers may comment that the side cargo doors bind or will not open.

Cause



The door hinges and pins may be binding or seized, due to internal corrosion. This condition is most commonly noted with the original hinge design shown above.

Correction

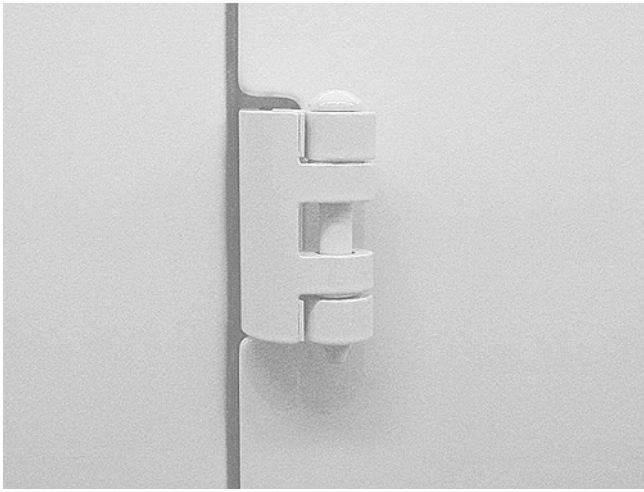

Note: A new design for the body side cargo door hinge, shown above, was developed to provide improved resistance to corrosion. New service part kits (which include the body and door side hinges, plates, bolts, stop, pin and instruction sheet) were released for the four hinge locations.

Replace the applicable upper or lower side cargo door hinge with one of the new service replacement kits listed in the part table below. You **MUST** replace both door and body side hinges. The following installation instructions are also supplied on the instruction sheet within each hinge kit.

1. Remove the door trim panel for inner door access to the hinges.
2. Remove the body pillar trim panel for interior access to the hinges. It may be necessary to move the front seat forward, clear of the B-pillar.
3. Remove the door from the vehicle.

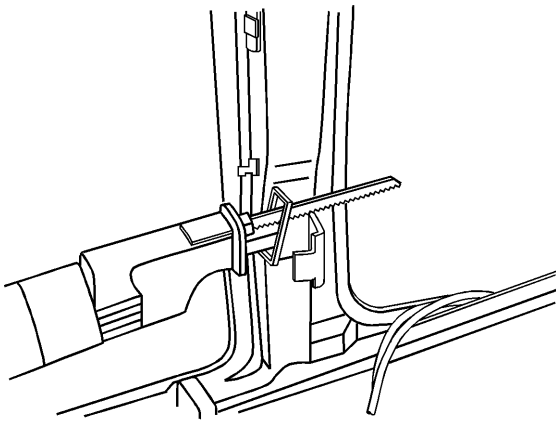

4. Cut the production body side of the door hinge using a reciprocating saw. This is necessary to gain access for drilling out the welds.

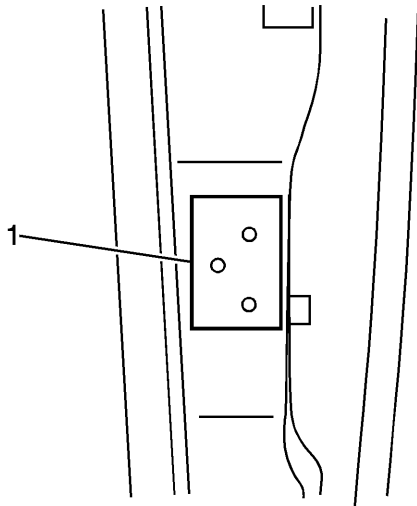

5. Remove any excess sealer surrounding the existing body side hinge, then tape around the periphery of the hinge to mark the hinge location (1).

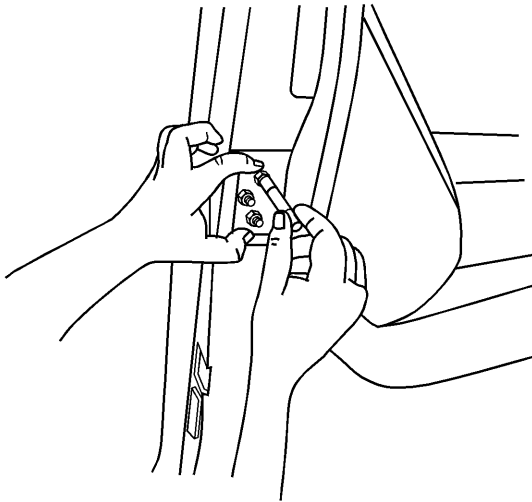

Important: For the forward most door (60 door), place the backing plate on the hinge surface and move the plate rearward 4 mm (0.16 in), then mark the three-hole pattern.

6. Place the service backing plate on the production hinge surface and mark the three-hole pattern.

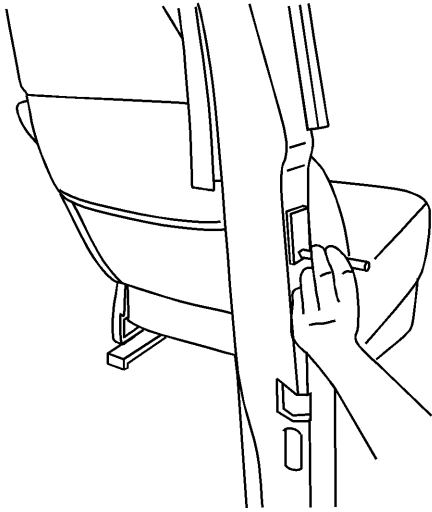

7. Center punch the marked three-hole pattern.

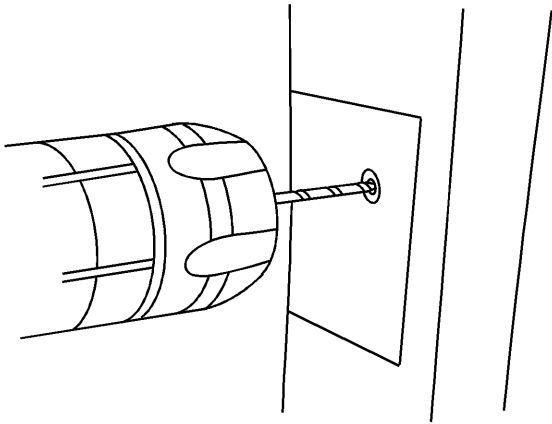

8. Using the center punches as guides, drill pilot holes using a 3 mm (1/8 in) drill bit, all the way through the production hinge and body pillar.
9. Lightly sand the body side hinge surface to locate the three production welds. Look for the witness marks.
10. Center punch the three production welds for locating the drill bit.

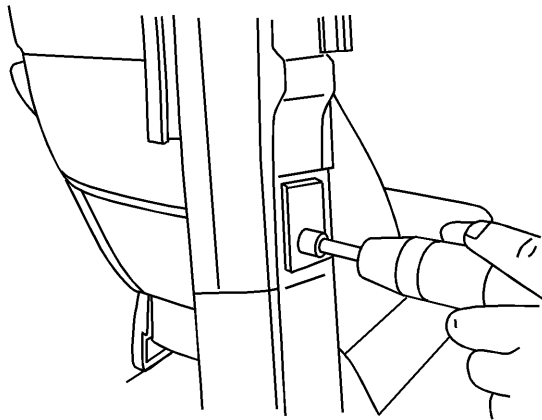

11. Using the center punch locations, use a 19 mm (3/4 in) rota-broach to drill out the remainder of the production hinge, WITHOUT drilling through the body side hinge pillar.
12. Cut the hinge weld nuggets off.
13. Grind the pillar hinge mating surface flush.
14. Using the pilot holes drilled (through the pillar) to center the drill bit, drill 13 mm (33/64 in) holes through the pillar (three locations).
15. On the rear most door (40 door), drill a 3.0 mm (1/8 in) pilot hole completely through the welds at each center punch mark on the body side hinge bases.
16. Using the 3.0 mm pilot holes as guides, drill out the three welds in the door side hinge and body side hinge base, with a 13.0mm (33/64 in) drill bit. The 13.0 mm holes in the pillar will provide for some door adjustment when reinstalling the door assembly.
17. A small amount of weld may still retain either the hinge base to pillar or hinge base to the door. Drive a chisel between the hinge base and door, or pillar to separate the hinge from either pillar or door.
18. Dress and prepare the body hinge pillar and door as required for replacement of hinges. Ensure that the hinge seating zones are flat to ensure good seating for the backing plates. Also deburr holes on the inside of the door and on the inside of the hinge pillar.
19. Tape around the periphery of the door side hinge to mark the hinge location.
20. Locate the approximate center of the three welds on the door side hinge base.
21. Center punch to mark the location of the welds.
22. Drill pilot holes with a 3 mm (1/8 in) drill bit all the way through the production hinge and the door inner and reinforcing plate.
23. Using the 3 mm pilot holes as a guide, drill out the three welds with a 13mm (33/64 in) drill bit. The 13 mm holes allow for some door adjustment when reinstalling the door assembly.
24. A small amount of weld may still retain the hinge base to door. Drive a chisel between the hinge base and panel to separate the hinge from the door.
25. Dress and prepare the door as required for the replacement hinge. Ensure that the hinge seating zone is flat, to ensure good seating for the backing plate, and deburr the holes on the inside of the door.

Important: For the proper refinish materials to use, refer to the GM Globally Approved Refinish Materials Information (GMW-15406). The refinish materials information is online at the [GMGOODWRENCH WEB SITE*](http://www.gmgoodwrench.com). Printed books have been discontinued. To access the site, follow these steps:

- Go to www.gmgoodwrench.com.
- Click on For Body Shops & Services link at the bottom of the page.
- Click on GM Technical Repair Information.
- Click on Paint Shop tab.

*In Canada, the GM Approved Refinish Materials booklet is also available in GM GlobalConnect by choosing LIBRARY, SERVICE and then PAINT SHOP.

26. Paint the inner and outer surfaces of the body hinge pillar and door, in the hinge mounting zones, using approved refinish materials.
27. Coat the surface of the body side hinge that mates to the hinge pillar with a medium bodied sealer.

Caution: Tapping plates supplied must be used to maintain structural integrity of the door hinge system. DO NOT substitute with conventional

washers.

28. Install the body side hinge within the scribed location on the pillar. Use the bolts and tapping plate supplied with the service replacement hinge kit and tighten the hinge bolts to the recommended preliminary torque.

Tighten: Tighten the hinge bolts to a preliminary torque of 5 Y (44 lb in).

29. Coat the surface of the door side hinge that mates to the door with a medium bodied sealer.

30. Install the door side hinge within the scribed location on the door. Use the bolts and tapping plate supplied with the service replacement hinge kit, and tighten the hinge bolts to recommended preliminary torque.

Tighten: Tighten the hinge bolts to a preliminary torque of 5 Y (44 lb in).

31. Apply a clear silicone sealant around the entire edge of the service hinges to prevent water leaks.

Tip: The door should not be closed completely until a visual check is made to determine if the latch fork bolt will correctly engage with the striker.

32. Install the door to the vehicle and align as required. Adjust the door striker if required.

33. Tighten all hinge bolts to the recommended final torque.

Tighten: Tighten all hinge bolts to a final torque of 20-25 Y (15-18 lb ft).

34. Paint the hinge assembly using approved refinish materials.

35. Install the hinge stop from the hinge kit.

36. Reinstall the door trim and pillar trim panels.

Parts Information

| Part Number | Description | Qty |
|-------------|----------------------------------|-----|
| 19257344 | Hinge Kit, Inter S/D Lwr (Dr Si) | 1 |
| 19257343 | Hinge Kit, Inter S/D Upr (Dr Si) | 1 |
| 19257342 | Hinge Kit, Rr S/D Lwr (Dr Si) | 1 |
| 19257341 | Hinge Kit, Rr S/D Upr (Dr Si) | 1 |

Warranty Information

For vehicles repaired under warranty, use:

| Labor Operation | Description | Labor Time |
|-----------------|---|------------------------------------|
| 1413640 | Intermediate Side Door Hinge Replacement- Body Side | Use Published Labor Operation Time |

GM bulletins are intended for use by professional technicians, NOT a "do-it-yourselfer". They are written to inform these technicians of conditions that may occur on some vehicles, or to provide information that could assist in the proper service of a vehicle. Properly trained technicians have the equipment, tools, safety instructions, and know-how to do a job properly and safely. If a condition is described, DO NOT assume that the bulletin applies to your vehicle, or that your vehicle will have that condition. See your GM dealer for information on whether your vehicle may benefit from the information.



WE SUPPORT VOLUNTARY TECHNICIAN CERTIFICATION