



Service Bulletin

PRELIMINARY INFORMATION

Subject: Tick, Buzz or Rattle Noise from Front of Dash, Transmission Filler Tube Cracked or Broken

Models: 2007-2013 Cadillac Escalade Models (excluding Hybrids)
2007-2013 Chevrolet Avalanche, Silverado, Suburban, Tahoe (excluding Hybrids)
2007-2013 GMC Sierra, Yukon Models (excluding Hybrids)

This PI is being revised to add model years, update the Condition/Concern, Recommendation/Instructions and Warranty Information. This PI replaces PIT4505F. Please discard PIT4505F and PI0522C.

Condition/Concern (For Vehicles Equipped with 6-Speed Transmission RPO MYC)

Some customers may comment on a tick or rattle noise that appears to be coming from the right hand, front of dash area. Upon further investigation the transmission filler tube may be found to be cracked or broken.

This condition may be caused by a resonance condition of the filler tube during certain driving conditions.

If the filler tube is not cracked or broken, the noise may be caused by contact between the filler tube and the front of dash area.

Condition/Concern (All Other Transmissions)

Some customers may comment on a rattle, buzz, tick, or vibration type noise that appears to be coming from the center of the dash. Root cause may be the transmission dipstick tube contacting the front of dash (cowl). If the transmission dipstick tube is too far rearward, it will contact the front of dash and vibrate, buzz, etc., causing the noise to sound like it is inside the dash area.

Recommendation/Instructions (For Vehicles Equipped with 6-Speed Transmission RPO MYC)

Inspect the transmission dipstick tube for any fractures and replace it if necessary. If no fracture is found, technicians should install a foam sleeve around the tube to absorb the vibration and adjust/bend the transmission dipstick tube away from the front of dash/cowl to provide additional clearance. When inspecting or adjusting the transmission dipstick tube it may appear to have enough clearance with the vehicle stopped. Verify that there is enough clearance to allow for powertrain movement during acceleration and deceleration. Inspect for contact while shifting between Drive and Reverse.

If the transmission filler tube is found to be cracked or broken, it should be replaced with a revised filler tube. This filler tube incorporates a foam damper near the top that prevents resonance related damage.

1. Open the hood.

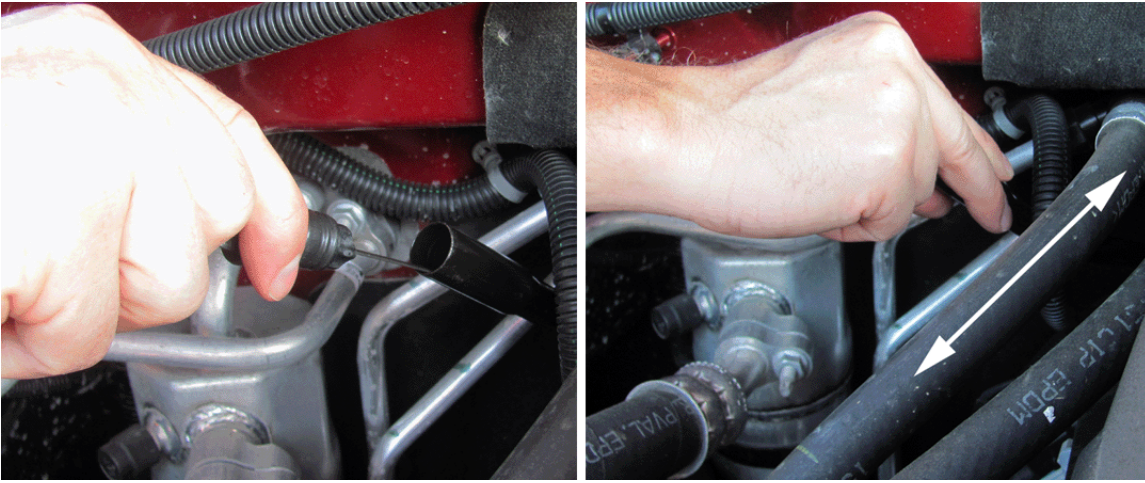

2. Remove the dipstick from the transmission filler tube.

Note: If required, use a step to aid in grasping the transmission filler tube correctly.

3. Grasp the transmission filler tube with your thumb and first two fingers of your right hand. Your thumb should be on the passenger side of the transmission filler tube and parallel to the filler tube.
4. Using only your thumb and the first two fingers of your right hand, force the transmission filler tube toward the driver's seating position and then back to the passenger's front wheel two times.
5. Determine if the transmission filler tube is damaged. An undamaged transmission filler tube will move less than two inches and spring back to its original position, while a damaged transmission filler tube will move greater than two inches and will not spring back to its original position. A damaged transmission filler tube will likely crack during this inspection.
 - If the transmission filler tube is not damaged, proceed to Step 6.
 - If the transmission filler tube is damaged, replace the transmission filler tube. Refer to Transmission Fluid Filler Tube and Seal Replacement in SI.

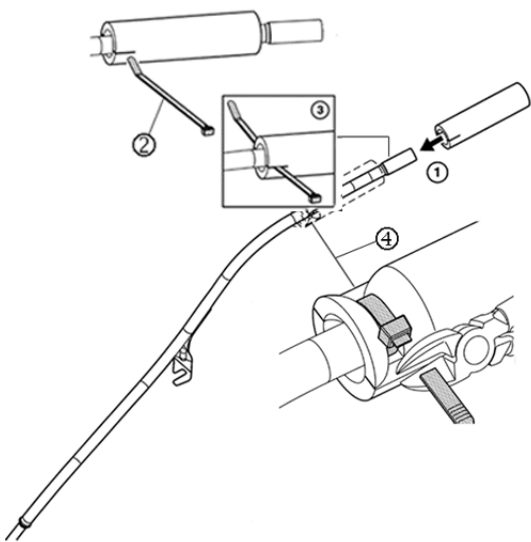

Note: The tie strap threads between the fill tube and half the foam damper using the slot in the sleeve. This is secured to the top half of the tube, leaving the lower half of the damper free.

6. Install a foam damper (sleeve) on the upper end of the transmission filler tube using a tie strap. Refer to the illustration.
7. Install the transmission dipstick.
8. Close the hood.

Important: It is recommended that a foam damper sleeve be installed, if not already in place, any time the transmission is removed from the vehicle for any reason.

Important: Do not alter or reduce the length of the fill tube. By design, the fill tube extends into the transmission pan to stabilize the oil level indicator and provide an accurate oil level reading. If the tube is shortened, the oil level reading may not be accurate causing an under fill or over fill condition and resultant damage to the transmission.

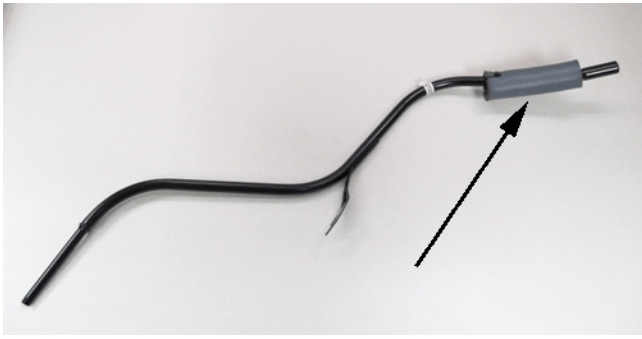

Important: The foam attached to the upper end of the tube is the damper. Do not mistake this foam for packaging material. Do not remove this foam from the tube.

Recommendation/Instructions (All Other Transmissions)

To correct this concern adjust/bend the transmission dipstick tube away from the front of dash/cowl to provide additional clearance. When inspecting or adjusting the transmission dipstick tube, it may appear to have enough clearance with the vehicle stopped. Verify that there is enough clearance to allow for powertrain movement during acceleration and deceleration. Inspect for contact while shifting between Drive and Reverse.

Parts Information

Part Number	Description	Qty
24260606	TUBE, TRANS FLUID FILL	1
24262134	SLEEVE, TRANS FLUID FILLER TUBE	1

Warranty Information

For vehicles repaired under the U.S. (5 years/100,000 miles or Canadian (5 years/160,000 km) Powertrain Warranty, use:

For Cadillacs repaired under the U.S. (6 years/70,000 miles or Canadian (6 years/110,000 km) Powertrain Warranty, use:

Labor Operation	Description	Labor Time
K9565*	Adjust Transmission Dipstick Tube and/or Install Transmission Fluid Filler Tube Sleeve	0.2 hr
Add	Replace Transmission Filler Tube (6-Speed Transmissions Only)	0.5 hr
*This is a unique labor operation for bulletin use only. It will not be published in the Labor Time Guide.		

GM bulletins are intended for use by professional technicians, NOT a "do-it-yourselfer". They are written to inform these technicians of conditions that may occur on some vehicles, or to provide information that could assist in the proper service of a vehicle. Properly trained technicians have the equipment, tools, safety instructions, and know-how to do a job properly and safely. If a condition is described, DO NOT assume that the bulletin applies to your vehicle, or that your vehicle will have that condition. See your GM dealer for information on whether your vehicle may benefit from the information.



WE SUPPORT VOLUNTARY TECHNICIAN CERTIFICATION