

Electric Vehicle Charge Check

Service Category General

Section Pre-Delivery Service

Market USA

Toyota Supports
 ASE Certification 

Applicability

YEAR(S)	MODEL(S)	ADDITIONAL INFORMATION
2013	RAV4 EV	

Introduction

To ensure the off-board charging functions and vehicle charging system are operating properly, inspect the charging functions during Pre-Delivery Service (PDS) following the procedures in this bulletin.

NOTICE

Be sure to carefully review, and understand, all applicable Repair Manual and Owner's Manual operational procedures and notes for charging before performing this inspection.

Warranty Information

OP CODE	DESCRIPTION	TIME	OFP	T1	T2
N/A	Not Applicable to Warranty	–	–	–	–

Electric Vehicle Charge Check

Component Location

Figure 1.

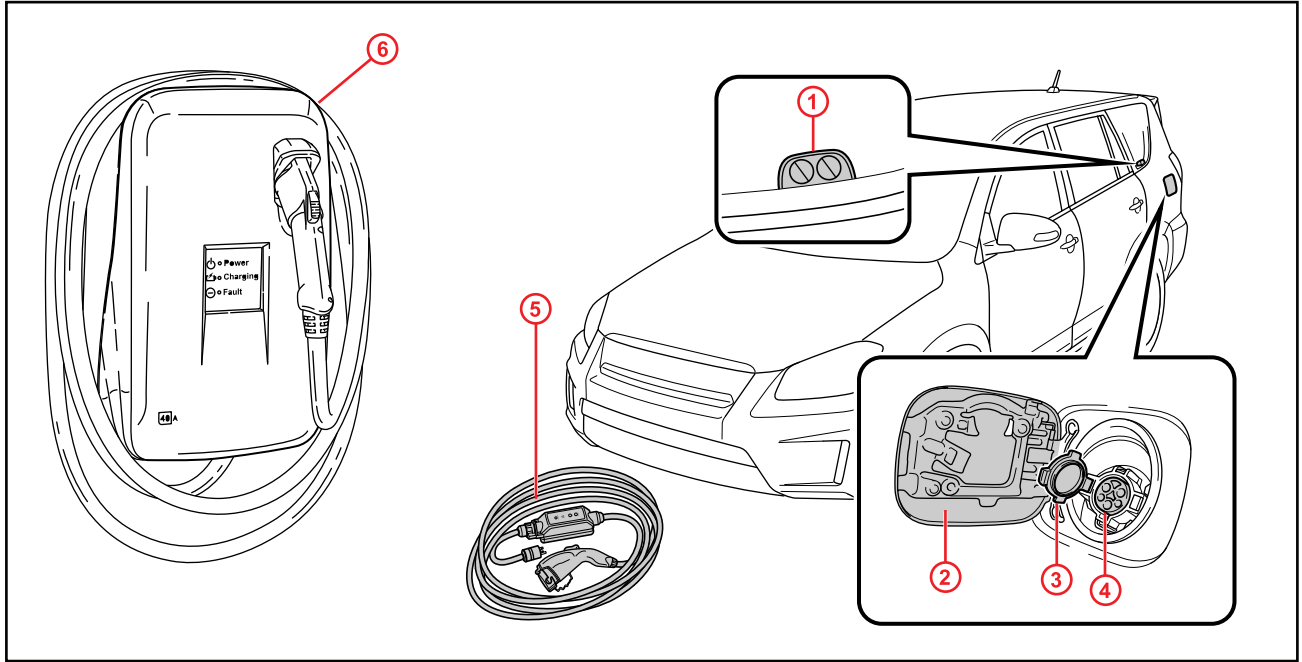

1	Charging Indicator
2	Charging Port Door
3	Charging Port Cap

4	Charging Port
5	Charging Cable with CCID (in trunk)
6	Vehicle Charging Station

Before Inspection

There are two separate ways the RAV4 EV can be charged. Please use the information below for instructions when using either method.

- Use the Vehicle Charging Station (up to 5 hours to fully charge).
- Use Charging Cable (w/CCID) (up to 50 hours to fully charge).

To Charge Vehicle with the Vehicle Charging Station

When using the Vehicle Charging Station, observe the following precautions.

NOTE
Cables must meet SAE J1772 AND Toyota requirements to be used for charging this vehicle.

Electric Vehicle Charge Check

To Charge Vehicle with the Vehicle Charging Station (Continued)

CAUTION

- Do NOT attempt to disassemble or repair the charging cable, connector or plug.
- Do NOT subject the charging cable, connector or plug to strong force or impact.
- Do NOT forcefully fold the charging cable or damage the charging cable with sharp objects.
- Do NOT fold the charging connector or plug or insert foreign objects into them.
- Hold the body of the charging connector or plug when removing or inserting.
- Avoid exposing the plug to water or moisture.

Inspection

CAUTION

Do NOT charge if the outside temperature is -22°F (-30°C) or below, as charging time will be increased and charging equipment may be damaged.

1. Confirm the following before charging:

- The "POWER" switch is OFF.
- The parking brake is applied.
- Vehicle is in the Park position. The "P" position switch (transmission shift main switch) is ON.
- There is NO electrical load being applied, such as lights, wipers, audio system, seat heaters, etc.
- Release the charging port door by pulling up on the lever under the driver's seat.

Electric Vehicle Charge Check

To Charge Vehicle with the Vehicle Charging Station

Inspection (Continued)

2. Check Charging Function.

CAUTION

- Check that the charging cable and charging inlet are **NOT** damaged.
- Check that the tips of the plug have **NOT** been deformed.
- If the plug is dirty or dusty, clean it before inserting. **DO NOT perform this if the charging station is powered.**
- Do **NOT** touch the electrical terminals of the charging connector or short them with foreign objects.
- Do **NOT** get water in the charging inlet.
- Do **NOT** wash the vehicle while the charging cable is connected to the vehicle.
- Do **NOT** charge with the charging cable coiled or bundled.
- After connecting the charging cable, confirm that it is **NOT** bent.
- Do **NOT** place heavy objects on the charging cable.
- Do **NOT** stand or walk on, or drive over the charging cable.
- Do **NOT** connect the plug if your hands are wet.
- Do **NOT** charge the vehicle during a lightning storm.

- A. Check the condition of the charging cable of the Charging Station.
- B. Check that the power indicator on the Charging Station is illuminated.
- C. Unlock the charging port cap by moving the lock.
- D. Remove the charging cable from the Charging Station, confirm connector direction and insert it into the charging port.

HINT

- When inserting, make sure **NOT** to press the latch release button.
- Align with the guide position shown on the underside of the charging connector, and push in until a click is heard.

Electric Vehicle Charge Check

To Charge Vehicle with the Vehicle Charging Station

Inspection (Continued)

E. Depending on the battery SOC, check the status of the charging indicator lights to confirm charging is occurring. One of the following light states should display depending upon battery SOC.

- (1) One light flashing, one light off.
- (2) One light flashing, one light illuminated.

Figure 2.

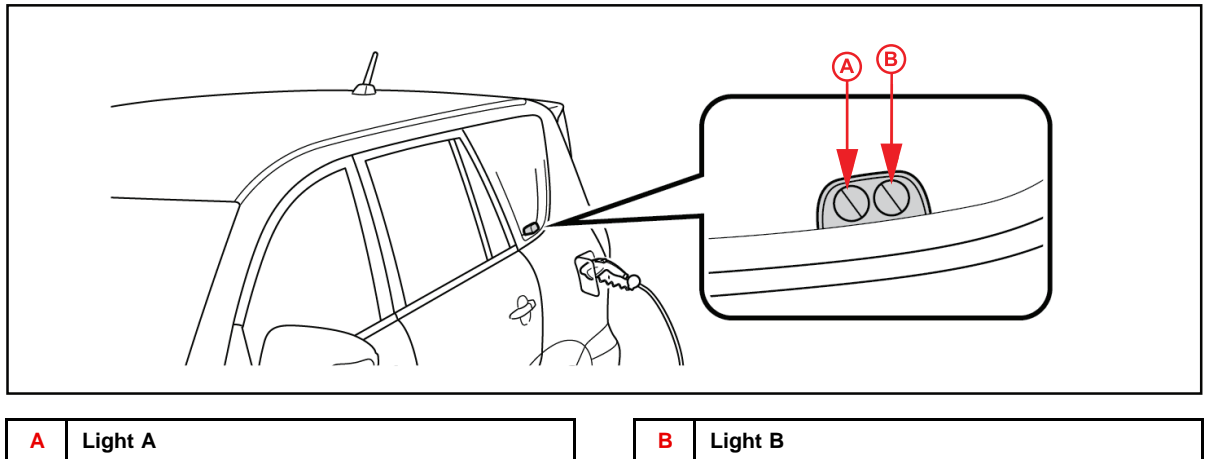

Check the status of the charging indicator.

The charging indicator consists of 2 lights that display charging status by illuminating, flashing, and turning off as follows.

CHARGING STATUS	CHARGING INDICATOR	
	LIGHT A	LIGHT B
The charging cable is connected to the vehicle and the charging and/or pre-climate schedule is set	Lights A and B flash ON and OFF alternatively for 10 minutes. (After 10 minutes, both lights remain OFF until charging starts)	
Charge level is less than 49%	Flashes	OFF
Charge level is between 50% and less than 99%	Illuminates	Flashes
Charging is complete	Both lights A and B illuminate for 10 minutes. (After 10 minutes, both lights turn OFF)	
Malfunction occurred during charging	Both lights A and B quickly flash simultaneously for 10 seconds. (After 10 seconds, both lights turn OFF)	

Electric Vehicle Charge Check

To Charge Vehicle with the Vehicle Charging Station

Inspection (Continued)

HINT

- For safety purposes, the vehicle will not "Ready On" while the charging cable is connected to the vehicle, even if the "POWER" switch is operated.
- If the charging cable is connected while the "READY" indicator light is illuminated, the vehicle will "Ready Off" automatically, and driving will not be possible.
- When the charging cable is connected to the vehicle, the shift position cannot be changed from "P" to another position.
- If the latch release button is pressed, charging will not begin even if the charging cable is connected.
- The indicator lights will not flash or turn on when the charging cable is not connected properly.

F. Check energy monitor.

If the "POWER" switch is cycled ON during charging, the current charging status and the amount of time needed until charging is complete will be displayed on the energy monitor.

After confirming, cycle the "POWER" switch to OFF to turn off the display. If the display is left on, charging will take longer.

HINT

- The first time the "POWER" switch is cycled ON after charging is completed, a message detailing the results of the charging will be displayed.
- If an operation which cannot be carried out is attempted during charging, a warning message will be displayed.

3. After Charging:

- A. When charging is complete, both lights will illuminate for 10 minutes and then turn OFF.
- B. Pull the charging connector towards you while pressing the latch release button.
- C. Place the charging cable back into the Charging Station dock.
- D. Close the charging port cap and close the charging port door.

Electric Vehicle Charge Check

To Charge Vehicle with the Charging Cable (w/CCID)

1. When using the Charging Cable with Charging Circuit Interrupting Device (CCID), observe the following precautions.

NOTE

Cables other than those intended for exclusive use with this vehicle cannot be used for charging.

CAUTION

- Do NOT attempt to disassemble or repair the charging cable, connector, plug, or CCID.
- Do NOT subject the charging cable, connector, plug, or CCID to strong force or impact.
- Do NOT forcefully fold the charging cable or damage the charging cable with sharp objects.
- Do NOT fold the charging connector or plug or insert foreign objects into them.
- Hold the body of the charging connector or plug when removing or inserting.
- Remove the charging connector from the vehicle's charging inlet FIRST, before removing the plug from the outlet.
- Do NOT pull the cable to remove the charging connector from the vehicle or the plug from the outlet.
- Avoid exposing the plug to water or moisture.

2. Power Sources:

NOTE

Confirm power sources meet the following criteria before charging.

- A. External power source must be AC 120V outlet (NEMA 5-15R) with a Ground-Fault Circuit-Interrupter (GFCI) and a circuit breaker. Use of a 15A individual circuit is strongly recommended to ensure the charging cable operates properly.

CAUTION

- Do NOT connect the charging cable to a multi-outlet adapter, multi-plugs, or conversion plug.
- Do NOT connect the charging cable to an extension cord.
- Do NOT connect the charging cable to a power strip.

Electric Vehicle Charge Check

To Charge Vehicle with the Charging Cable (w/CCID) (Continued)

- B. When charging outdoors, make sure to connect to a weatherproof outlet that is certified for outdoor use.

CAUTION

- **Do NOT charge if the outside temperature is -22°F (-30°C) or below as it is possible that charging will take longer and equipment related to charging will be damaged.**
- **Make sure to connect to a weatherproof outlet for outdoor use. (If rain falls during charging, take care that rainwater does NOT run along the length of the cable and enter the outlet).**

Inspection

1. Confirm the following before charging:
 - The parking brake is applied.
 - Vehicle is in the Park position. The “P” position switch (transmission shift main switch) is ON.
 - There is NO electrical load being applied, such as lights, wipers, audio system, seat heaters, etc.
 - The “POWER” switch is OFF.
2. Check Charging Function.
 - A. Check the condition of the charging cable provided with the vehicle.
 - B. Insert the charging cable firmly into the outlet of the external power source.
 - C. Check that the power indicator of the CCID is illuminated.

HINT

If the power indicator does NOT illuminate, ensure that the plug is firmly connected with the outlet.

- D. Press the test button on the CCID to check that the electrical leakage detection function operates properly.
 - If the error warning indicator illuminates when the test button is pressed, the function is operating correctly.
 - After the test has been completed, press the reset button to turn off the error warning indicator.

HINT

Charging cannot be carried out while the error warning indicator is illuminated.

Electric Vehicle Charge Check

To Charge Vehicle with the Charging Cable (w/CCID)

Inspection (Continued)

- E. Press the vehicle's charging port lid to open.
- F. Remove the charging connector cap.
- G. Insert the charging cable into the vehicle's charging inlet.

HINT

- When inserting, make sure **NOT** to press the latch release button.
- Align with the guide position shown on the underside of the charging connector, and push in until a click is heard.

CAUTION

- Check that the outlet, charging cable, and charging inlet are **NOT** damaged.
- Check that the tips of the plug have **NOT** been deformed.
- If the plug is dirty or dusty, clean it before inserting.
- Do **NOT** touch the electrical terminals of the charging connector or short them with foreign objects.
- Do **NOT** get water in the charging inlet.
- Do **NOT** wash the vehicle while the charging cable is connected to the vehicle.
- Do **NOT** charge with the charging cable coiled or bundled.
- After connecting the charging cable, confirm that it is **NOT** bent.
- Do **NOT** place heavy objects on the charging cable.
- Do **NOT** stand or walk on, or drive over, the charging cable.
- If charging is interrupted, remove the charging connector from the vehicle before removing the plug.
- Do **NOT** insert the plug if the outlet is submerged in water or snow. If the plug has already been inserted and it is necessary to remove it, first switch the circuit breaker **OFF**, and then remove the plug.
- If charging while it is raining or snowing check that no snow, water, or ice have accumulated around the charging connector terminals and the vehicle charging inlet.
- Do **NOT** connect the plug if your hands are wet.
- Do **NOT** charge the vehicle during a lightning storm.

Electric Vehicle Charge Check

To Charge Vehicle with the Charging Cable (w/CCID)

Inspection (Continued)

H. Confirm that the charging indicator is illuminated.

HINT

- Charging cannot be started if the charging indicator does NOT illuminate when the charging cable is inserted.
- The charging indicator will turn off when charging is completed.
- For safety purposes, the vehicle will not "Ready On" while the charging cable is connected to the vehicle, even if the "POWER" switch is operated.
- If the charging cable is connected while the "READY" indicator light is illuminated, the vehicle will "Ready Off" automatically, and driving will not be possible.
- When the charging cable is connected to the vehicle, the shift position cannot be changed from "P" to another position.
- If the latch release button is pressed, charging will not begin even if the charging cable is connected.

I. Check energy monitor.

If the "POWER" switch is cycled ON during charging, the current charging status and the amount of time needed until charging is complete will be displayed on the energy monitor.

After confirming, cycle the "POWER" switch to OFF to turn off the display. If the display is left on, charging will take longer.

HINT

- The first time the "POWER" switch is cycled ON after charging is completed, a message detailing the results of the charging will be displayed.
- If an operation which cannot be carried out is attempted during charging, a warning message will be displayed.

J. If the error warning indicator on the CCID stays on during charging, press the reset button on the CCID. If the error warning indicator does NOT turn off after the reset button is pressed, an electrical leakage may be occurring in the path to the power source, or there may be a problem with the charging cable or the charging system.

Electric Vehicle Charge Check

To Charge Vehicle with the Charging Cable (w/CCID)

Inspection (Continued)

3. After Charging:

- A. Pull the charging connector towards you while pressing the latch release button.
- B. Attach the charging connector cap and close the charging port lid.
- C. Remove the plug from the outlet.

CAUTION

- Hold the body of the plug when removing.
- Do NOT pull on the cable.

- D. Place the charging cable in the cargo area of the vehicle.