



2013 PRE-DELIVERY SERVICE CHECK SHEET

June 2013 Rev 1

BEFORE INSPECTION	OK	Adjust/Repair
01 Install DOME fuse (see page 2).....	<input type="checkbox"/>	<input type="checkbox"/>
02 Install radio antenna.....	<input type="checkbox"/>	<input type="checkbox"/>

FUNCTIONAL OPERATION		
<i>Apply parking brake and cycle ignition "IG-ON"; place gear selector in reverse, turn on lights and rear defogger. Unlock all doors, release fuel door, release rear hatch.</i>		
01 Check dome, courtesy, map, and sun visor lights*	<input type="checkbox"/>	<input type="checkbox"/>
02 Check warning/indicator lights, gauges, and horn	<input type="checkbox"/>	<input type="checkbox"/>
03 Check windshield wipers and washers	<input type="checkbox"/>	<input type="checkbox"/>
04 Check headlights, instrument lights, turn signals, dimmer switch, emergency flashers, and brake lights	<input type="checkbox"/>	<input type="checkbox"/>
05 Check inside/outside rear view mirror operation/adjustment.....	<input type="checkbox"/>	<input type="checkbox"/>
06 Check cigarette lighter* and power outlet	<input type="checkbox"/>	<input type="checkbox"/>
07 Check audio/navigation* system, set SSP to xD*, & set clock	<input type="checkbox"/>	<input type="checkbox"/>
08 Install shift-lock override button cover	<input type="checkbox"/>	<input type="checkbox"/>
09 Check that the electroluminescent dash illuminates when door is opened**	<input type="checkbox"/>	<input type="checkbox"/>
10 Check that the shift knob illuminates**	<input type="checkbox"/>	<input type="checkbox"/>

WALKAROUND INSPECTION		
<i>Start at left front door. Check window and door lock operation (from master power switch, if equipped). Continue around vehicle in a counterclockwise direction checking each door and window operation, child door locks, seat belts, interior condition, all lights, luggage compartment contents. Finish by checking headlight aim and continue into UNDER HOOD checks.</i>		
01 Check door and door lock operation, including each wireless remote control/theft deterrent system*	<input type="checkbox"/>	<input type="checkbox"/>
02 Check power window operation.....	<input type="checkbox"/>	<input type="checkbox"/>
03 Check that engine starts with all keys.....	<input type="checkbox"/>	<input type="checkbox"/>
04 Check that child safety door locks are in normal (unlocked) position	<input type="checkbox"/>	<input type="checkbox"/>
05 Check seats and seat belt operation	<input type="checkbox"/>	<input type="checkbox"/>
06 Check rear defogger.....	<input type="checkbox"/>	<input type="checkbox"/>
07 Check side marker, tail, backup, and license plate lights	<input type="checkbox"/>	<input type="checkbox"/>
08 Check rear hatch trim appearance	<input type="checkbox"/>	<input type="checkbox"/>
09 Adjust spare tire pressure, inspect for damage, and check jack and tool installation	<input type="checkbox"/>	<input type="checkbox"/>
10 Check headlight aim	<input type="checkbox"/>	<input type="checkbox"/>
11 Check that front and rear exterior Scion badges illuminate after unlocking vehicle**	<input type="checkbox"/>	<input type="checkbox"/>

UNDER HOOD		
01 Check engine oil and ATM* fluid levels.....	<input type="checkbox"/>	<input type="checkbox"/>
02 Check brake and clutch* fluid levels.....	<input type="checkbox"/>	<input type="checkbox"/>
03 Check engine coolant level.....	<input type="checkbox"/>	<input type="checkbox"/>
04 Check windshield washer fluid level	<input type="checkbox"/>	<input type="checkbox"/>
05 Check battery state-of-charge using Digital Battery System Analyzer (SOC Reading: _____%)	<input type="checkbox"/>	<input type="checkbox"/>
06 Inspect for fuel, oil, coolant, and other fluid leaks	<input type="checkbox"/>	<input type="checkbox"/>

* Inspect or install when equipped/required.
** For Scion Series 10 vehicles only.

UNDER VEHICLE (ON HOIST)	OK	Adjust/Repair
01 Remove disc brake anti-rust covers/anti-corrosion wheel film*	<input type="checkbox"/>	<input type="checkbox"/>
02 Inspect tires for defects/damage	<input type="checkbox"/>	<input type="checkbox"/>
03 Activate and Initialize Tire Pressure Warning System (TPWS) (see page 2)	<input type="checkbox"/>	<input type="checkbox"/>
04 Install wheel covers/caps/spare tire wheel covers*	<input type="checkbox"/>	<input type="checkbox"/>
05 Install rubber body plugs (stored in glove box)	<input type="checkbox"/>	<input type="checkbox"/>
06 Inspect for fuel, oil, coolant, and other fluid leaks	<input type="checkbox"/>	<input type="checkbox"/>
07 Visually check bolts and nuts on chassis and powertrain for looseness.....	<input type="checkbox"/>	<input type="checkbox"/>
08 Inspect under the vehicle for damage, rust, etc.	<input type="checkbox"/>	<input type="checkbox"/>

ROAD TEST
<i>A complete road test helps assure customer satisfaction. Drive vehicle over a variety of road surfaces and driving conditions. Check for unusual noise and driving performance.</i>

Enter Odometer Reading
Reading Before Test: _____ Reading After Test: _____

01 Check cold engine operation.....	<input type="checkbox"/>	<input type="checkbox"/>
02 Check engine operation during warm-up	<input type="checkbox"/>	<input type="checkbox"/>
03 Check engine at normal operating temperature	<input type="checkbox"/>	<input type="checkbox"/>
04 Check clutch or automatic transmission operation.....	<input type="checkbox"/>	<input type="checkbox"/>
05 Check brake and parking brake operation	<input type="checkbox"/>	<input type="checkbox"/>
06 Check steering operation and off-center/vehicle pull/flutter	<input type="checkbox"/>	<input type="checkbox"/>
07 Inspect for abnormal noise and vibration	<input type="checkbox"/>	<input type="checkbox"/>
08 Inspect for squeaks and rattles	<input type="checkbox"/>	<input type="checkbox"/>
09 Check front and rear* heater and A/C* operation.....	<input type="checkbox"/>	<input type="checkbox"/>
10 Check speedometer operation	<input type="checkbox"/>	<input type="checkbox"/>
11 Check cruise control operation*	<input type="checkbox"/>	<input type="checkbox"/>

FINAL INSPECTION AND CLEANING		
01 Remove interior protective covers, unnecessary labels, tags, etc. (Remove just before delivery to customer)	<input type="checkbox"/>	<input type="checkbox"/>
02 Verify floor mat application and install using retaining clips*	<input type="checkbox"/>	<input type="checkbox"/>
03 Visually inspect all interior parts for installation, damage, fit, dirt, etc.	<input type="checkbox"/>	<input type="checkbox"/>
04 Remove Rapgard™ and clear protective bumper film*	<input type="checkbox"/>	<input type="checkbox"/>
05 Wash and clean vehicle	<input type="checkbox"/>	<input type="checkbox"/>
06 Inspect paint finish for scratches, chips, rust, dents, damage, etc.	<input type="checkbox"/>	<input type="checkbox"/>
07 Inspect exterior body parts for proper installation, damage, rust, etc.	<input type="checkbox"/>	<input type="checkbox"/>
08 Place oil change sticker on inside of windshield, top left corner.....	<input type="checkbox"/>	<input type="checkbox"/>
09 Place Owner's Guide and first aid kit portfolio* in glove box	<input type="checkbox"/>	<input type="checkbox"/>
10 Perform Techstream Health Check	<input type="checkbox"/>	<input type="checkbox"/>
11 Install front license plate (see page 2)	<input type="checkbox"/>	<input type="checkbox"/>

Completion and retention of this form is required to comply with Toyota's Warranty Policy.

TECHNICIAN'S SIGNATURE _____

SERVICE MANAGER'S SIGNATURE _____

NAME (PLEASE PRINT) _____

NAME (PLEASE PRINT) _____

Date _____

Dealer Name _____

Dealer Code _____

Vehicle Identification Number (Sticker) _____

We hereby certify that all items on this form have been checked and corrected for proper operation as required.

DOME FUSE INSTALLATION

To minimize battery discharge, the DOME fuse has been removed and is stored in the engine compartment Relay Block. Install the DOME fuse using the procedures below.

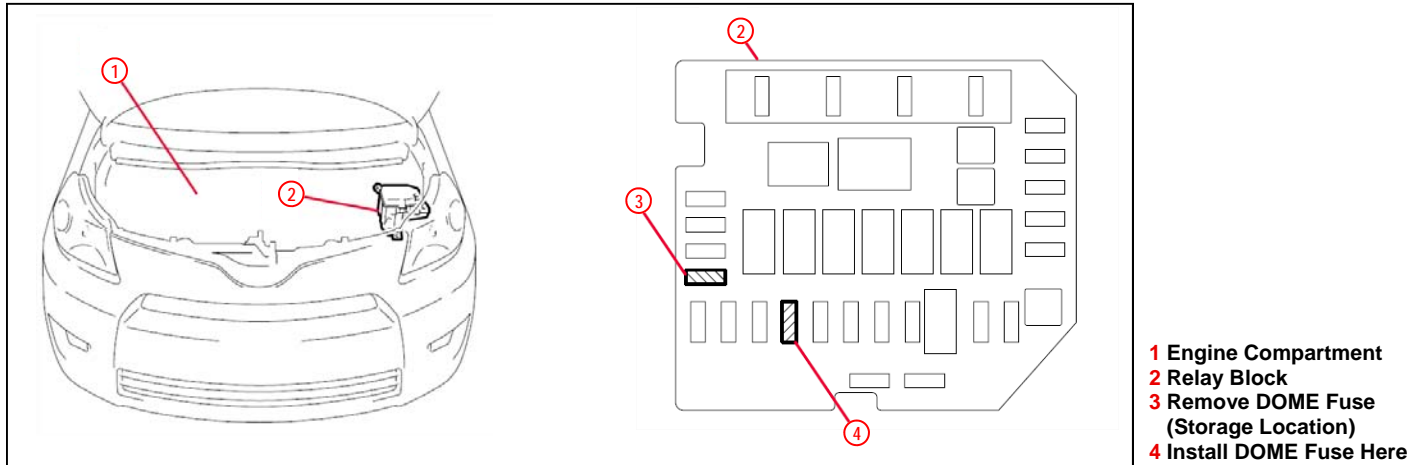

TPWS ACTIVATION & INITIALIZATION

Activation Procedure (Japan Built Vehicles Only)

1. Connect Techstream.
2. Cycle the IG switch to the "IG-ON" position and check that the Low Tire Pressure Warning Light blinks for 1 minute and then remains illuminated.
3. Press or remove the valve core to reduce the tire inflation pressure rapidly by 6 psi (0.4 kg/cm², 40 kPA), or more, within 30 seconds.
4. Check that the Low Tire Pressure Warning Light goes OFF after all the TPWS sensors are activated.

5. Using Techstream, check for DTCs (C2111-C2114). If no DTCs are stored, continue to Initialization procedure. If these DTCs are stored, repeat step 3.

Initialization Procedure

Refer to the Repair Manual for the [Initialization procedure](#). Please note the spare tire does not have a TPWS sensor.

NOTE

To adjust tire pressure correctly when outside temperature is significantly colder or warmer than shop temperature, follow the procedures outlined in the Tire Inflation Pressure Compensation and Adjustment service bulletin ([S-SB-0001-12](#)).

FRONT LICENSE PLATE INSTALLATION

For states that require a front license plate, please install per this procedure.

Installation Procedure

1. Align the installation holes on the front license plate with the dimples on the front bumper.
2. Directly screw 2 self-tapping screws into the dimples to install the front license plate.

NOTICE

- Do NOT pre-drill holes into the bumper
- Do NOT overtighten the self-tapping screws

Use self-tapping screws of a non-corroding type with the following dimensions.

Nominal Length: 15.0 — 20.0 mm (0.60 — 0.79 in.)

Diameter: 6.0 mm (0.24 in.)

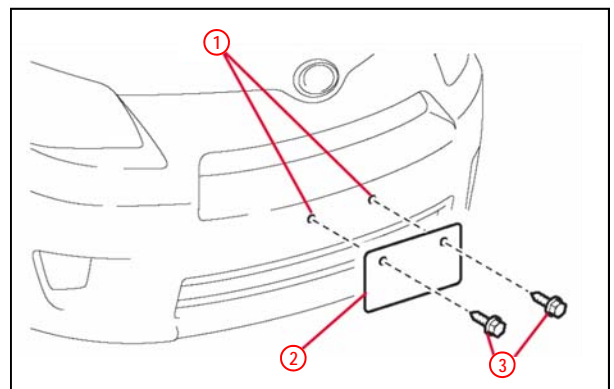

- 1 Dimples
- 2 License Plate
- 3 Self-tapping Screws