



Service Bulletin

PRELIMINARY INFORMATION

Subject: Broken or Separated Auxiliary Floor Mat Retainers, Floor Mat Retainer Won't Seat on Carpet

Models: 2010-2013 Buick LaCrosse
2011-2013 Buick Regal
2012-2013 Buick Verano
2008-2013 Cadillac CTS All Models including V-Series
2010-2013 Cadillac SRX
2011-2013 Chevrolet Cruze, Equinox, Volt
2012-2013 Chevrolet Sonic
2013 Chevrolet Malibu
2011-2013 GMC Terrain
2011-2013 Saab 9-4x

Condition/Concern

Some customers may comment on a broken auxiliary floor mat retainer and/or that the floor mat may be difficult to fully seat onto the carpet side retainer. Due to several changes in floor mat retainer design, and their suppliers, particular vehicle lines have varying breakpoints for the style of retainer their floor mats and carpet contain. Because the different styles/designs are not interchangeable, floor mats containing a non-matching retainer will not fully seat on the carpet side retainer and therefore, the mat retainer may break.

Recommendation/Instructions

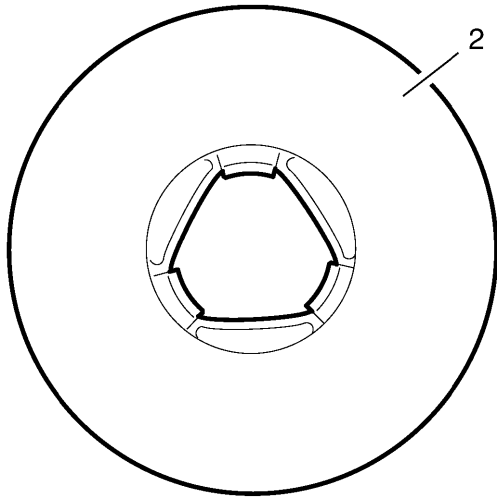
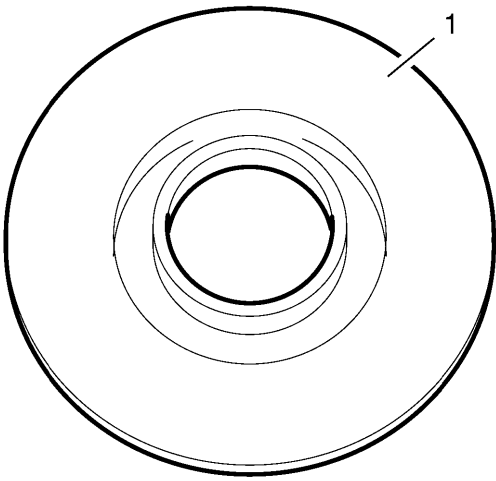

There are two different suppliers of auxiliary floor mat retainers for these vehicles, Saxonia and ITW, and the mat retainers and carpet retainers are NOT interchangeable between the two suppliers. Additionally, the ITW style have a first (V1.x) and second (V2.0) design. Look at the backside of the retainer on the auxiliary mat. If the center of the lower section is round, the retainer was made by Saxonia(1). If the center of the lower section has a triangle, the retainer was made by ITW (2). Furthermore, ITW V2.0 retainers can be identified by a "V2.0" embossed on the back side of the floor mat retainer.

Note: The procedure below is specific to replacement of the auxiliary floor mat retainers. If the carpet side retainer is damaged, service parts are currently available and replacement procedures are being developed for future population into SI.

Replace the auxiliary floor mat retainers using the following instructions:

1. Remove the auxiliary mat from the vehicle.

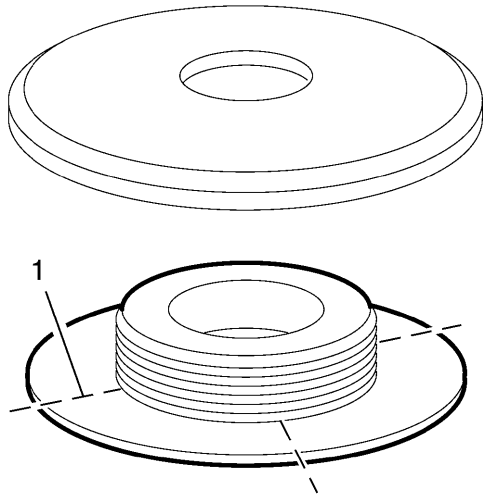

2. From the backside of the floor mat, cut four lines (1) through the plastic at the shown locations using a pair of cutters.
3. Using suitable pliers, break off each piece and push the remaining piece through the mat retainer hole.

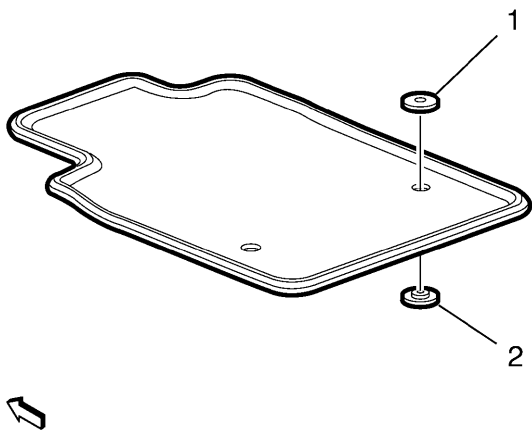

4. Align the upper piece of the mat retainer (1) to center of the mat retainer hole. Turn the mat over while maintaining the center position of the retainer.
5. Install the lower piece of the mat retainer (2) onto the mat, aligning it with the upper retainer. Push down hard to engage several retention rings.
6. Lightly tap on the retainer with a rubber mallet to engage the remaining retention rings.
7. Install the auxiliary floor mat to the vehicle.

Parts Information

For part numbers, usage and availability of the auxiliary floor mat retainer kits, see Carpet/Floor in Group 15.286 of the appropriate Parts Catalog. Each auxiliary floor mat contains two kits per mat.

Warranty Information

For vehicles repaired under warranty, use:

Labor Operation	Description	Labor Time
C9526*	Auxiliary Floor Mat Retainer Replacement (Includes One or all)	0.2 hr

*This is a unique labor operation for bulletin use only. It will not be published in the Labor Time Guide.

GM bulletins are intended for use by professional technicians, NOT a "do-it-yourselfer". They are written to inform these technicians of conditions that may occur on some vehicles, or to provide information that could assist in the proper service of a vehicle. Properly trained technicians have the equipment, tools, safety instructions, and know-how to do a job properly and safely. If a condition is described, DO NOT assume that the bulletin applies to your vehicle, or that your vehicle will have that condition. See your GM dealer for information on whether your vehicle may benefit from the information.



WE SUPPORT VOLUNTARY TECHNICIAN CERTIFICATION