

Ticking Noise from Rear Package Tray

Service Category Vehicle Exterior

Section Body Structure

Market USA

Scion Supports
 ASE Certification 

Applicability

YEAR(S)	MODEL(S)	ADDITIONAL INFORMATION
2013	FR-S	WMI(s): JF1

Introduction

Some 2013 model year FR-S vehicles may experience a ticking noise coming from the driver or passenger side of the rear package tray sheet metal while driving over rough surfaces. This is caused by spatter that is created during the weld process rubbing in between the sheet metal layers at specific weld points. Follow the Repair Procedure in this bulletin to reduce the gap between the sheet metal layers to address this condition.

Production Change Information

This bulletin applies to vehicles produced **BEFORE** the Production Change Effective VIN shown below.

MODEL	PRODUCTION CHANGE EFFECTIVE VIN
Scion FR-S	JF1ZNAA1#D1714778

Required Tools & Equipment

REQUIRED MATERIAL	QUANTITY
Castle® Endura™ Heavy Duty Penetrating Grease	1

REQUIRED TOOLS	QUANTITY
Ball Peen Hammer (16 oz.)	1
5 mm Hex Wrench	1

Ticking Noise from Rear Package Tray

Warranty Information

OP CODE	REPAIR PROCEDURE	DESCRIPTION	TIME	OFF	T1	T2
BD1305	1	Adjust Rear Panel From Trunk with Screwdriver*	0.2	SU003-01373	91	57
Combo A	2	Adjust Rear Panel From Trunk with Hammer*	0.2			
Combo B	3	Adjust Rear Panel From Inside*	0.9			

* Confirm the location of the noise and proceed to perform the applicable Repair Procedure. It may be necessary to perform multiple Repair Procedures to address this condition.

APPLICABLE WARRANTY

- This repair is covered under the Toyota Basic Warranty. This warranty is in effect for 36 months or 36,000 miles, whichever occurs first, from the vehicle's in-service date.
- Warranty application is limited to occurrence of the specified condition described in this bulletin.

Repair Procedure Overview

NOTE

It may be necessary to perform multiple repair procedures to address the condition.

1. Confirm the noise is coming from the Rear Package tray area.

HINT

Listen to the condition from the rear seat during a test drive to confirm the noise source.

2. Review Repair Procedure 1-3 before performing the repair to confirm the exact location of the noise.
3. Perform the repair procedures in order and only if necessary.
4. If the noise continues after each repair procedure is completed, reconfirm the noise location before completing the next repair procedure.
5. Confirm the repair with the vehicle reassembled.

Ticking Noise from Rear Package Tray

Repair Procedure 1

1. Test drive the vehicle to confirm that a noise is coming from the rear package tray area circled in Figures 2 and 3.

Figure 1.

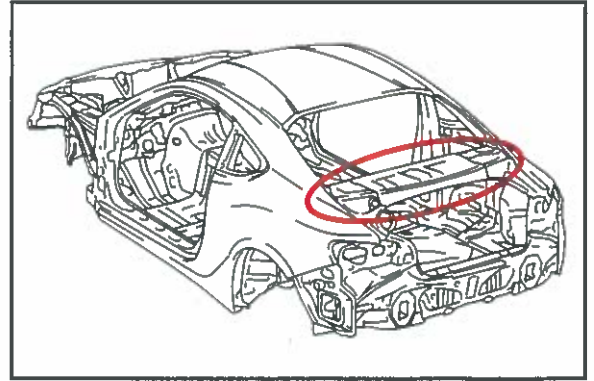

Figure 2. Driver Side

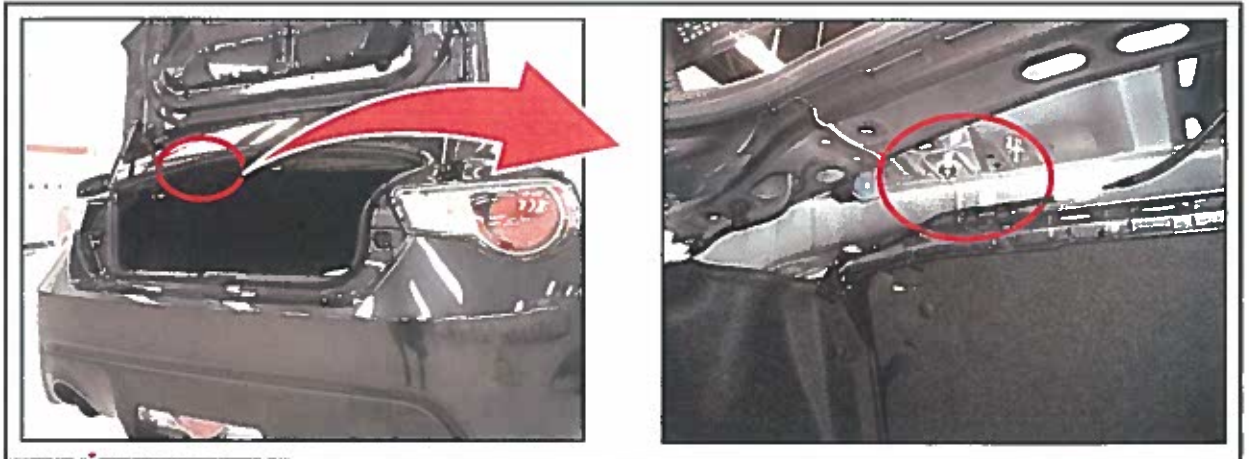
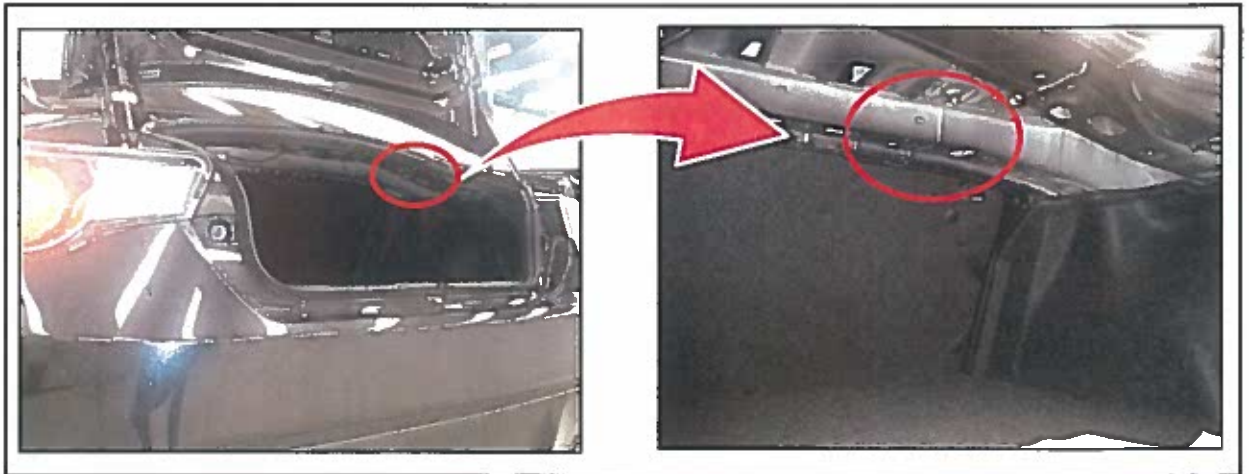

Figure 3. Passenger Side



Ticking Noise from Rear Package Tray

Repair Procedure 1 (Continued)

2. Adjust the gap between the lower and middle sheet metal panels as described below.

A. The noise source is located immediately adjacent to the vertical surface of the package tray as shown below. The adjustment area is located between the spot weld and vertical section.

Figure 4. Driver Side

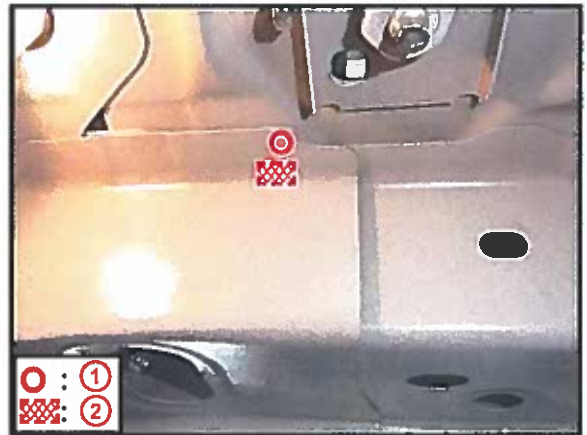

1	Spot Weld
2	Adjustment Area A

Figure 5. Passenger Side

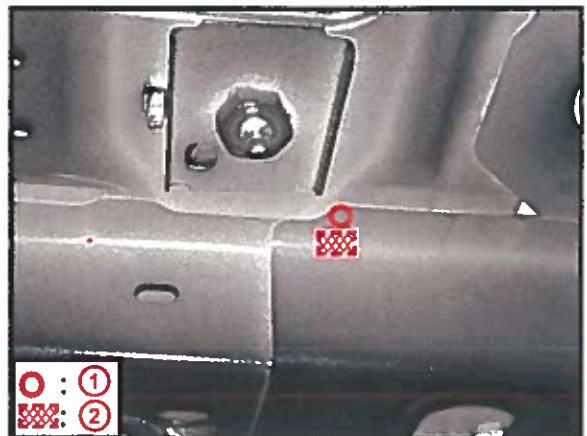

1	Spot Weld
2	Adjustment Area A

Ticking Noise from Rear Package Tray

Repair Procedure 1 (Continued)

- B. Use a hammer and a wide flat blade screwdriver to gently tap the identified area.

NOTICE

- To avoid damaging paint, use a piece of tape or fabric between the screwdriver blade and sheet metal.
- If the paint becomes damaged, use touch-up paint to repair the affected area.

Figure 6.

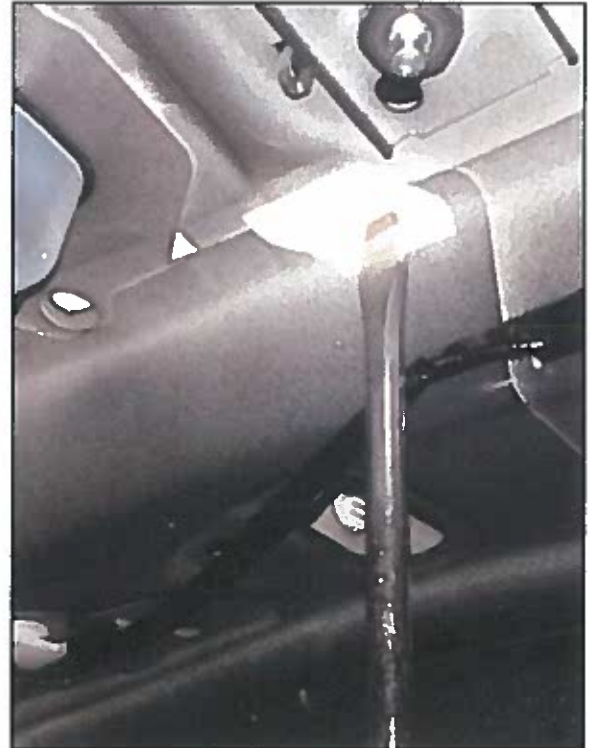

- C. Confirm the gap between the sheet metal panels is reduced.

3. Use Castle® Endura™ Heavy Duty Penetrating Grease between the sheet metal panels.

Figure 7.

- A. Insert the spray tube between the sheet metal panels as shown.
- B. Wipe away excess lubricant.

NOTICE

Do NOT use silicone-based lubricant because it can have adverse effects on electronic components.

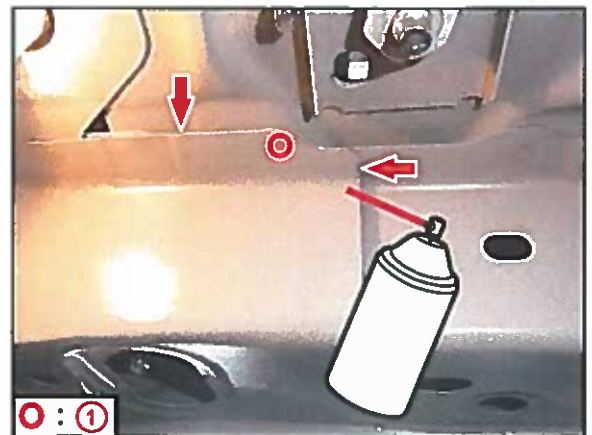

1 Spot Weld

4. Test drive vehicle and confirm that there is not a noise coming from the affected area.

Ticking Noise from Rear Package Tray

Repair Procedure 2 (If Applicable)

1. Confirm a noise is coming from the spot welded area shown in Figures 8 and 9. Noise source area is under the vertical section in Repair Procedure 1, shown in Figure 4.
 - A. Apply finger pressure to Adjustment Area B which is located between the 4 indicated spot welds to confirm that the noise is present.

Figure 8. Driver Side View From Under – Looking Up

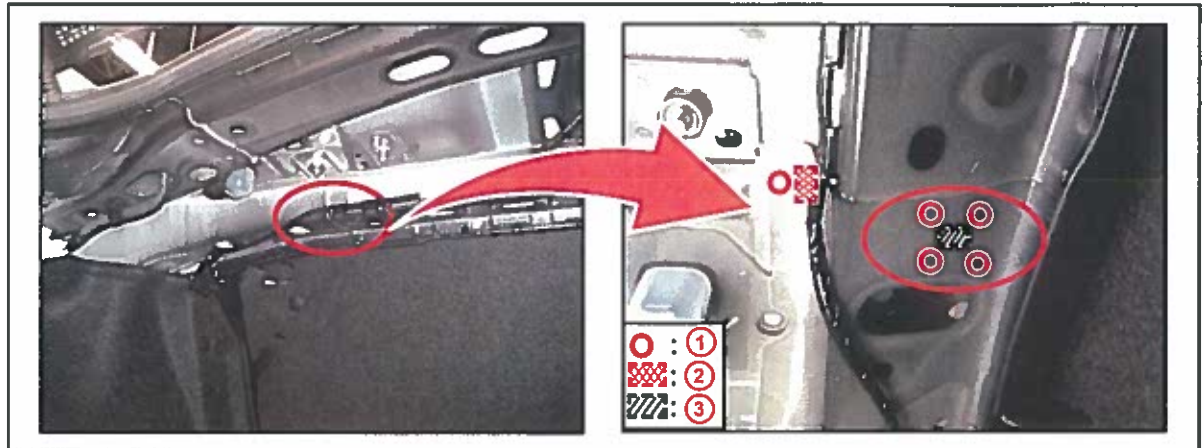

1	Spot Weld
2	Adjustment Area A

3	Adjustment Area B
---	-------------------

Figure 9. Passenger Side View From Under – Looking Up

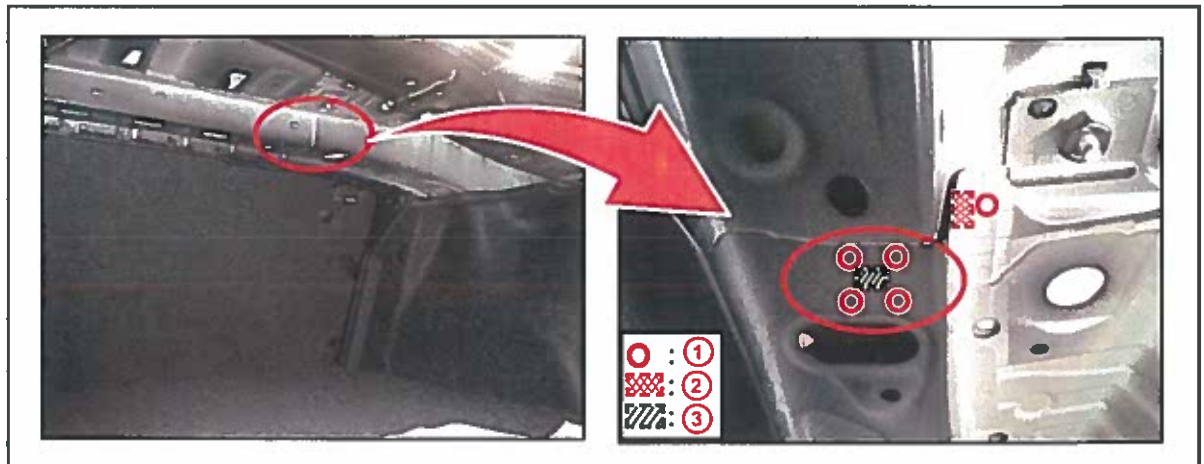

1	Spot Weld
2	Adjustment Area A

3	Adjustment Area B
---	-------------------

Ticking Noise from Rear Package Tray

Repair Procedure 2 (If Applicable) (Continued)

2. Adjust the gap between the lower and middle sheet metal panels.
 - A. Using the peen of the hammer, gently tap on Adjustment Area B (shown in Figures 8 and 9) by snapping the wrist with a 60 mm (approximately 2.36 in.) stroke.
 - B. Confirm the gap between the sheet metal sections has been reduced.
3. Test drive the vehicle and confirm that the noise is no longer present from the areas identified in Repair Procedure 1 or 2.

Repair Procedure 3 (If Applicable)

1. Confirm that the noise is coming from the rear package tray area as indicated below.

Figure 10. Driver Side View

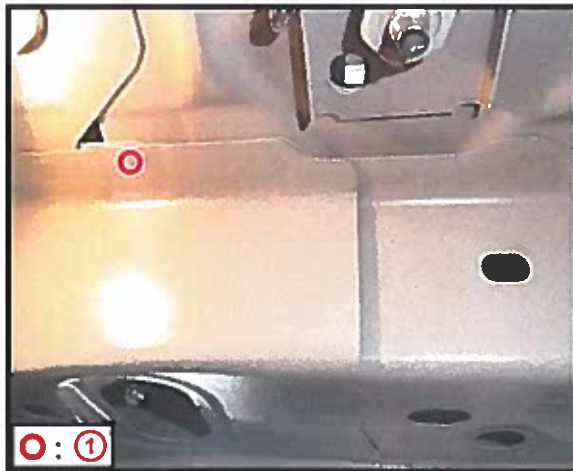

1	Spot Weld
---	-----------

Figure 11. Passenger Side View



1	Spot Weld
---	-----------

2. Remove the Rear Package Tray.

Refer to the Technical Information System (TIS), applicable model and model year Repair Manual. Follow Removal steps but do NOT remove the door control receiver.

- 2013 FR-S:
Vehicle Interior – Door Lock – “Door Lock: Door Control Receiver: [Removal](#)”

Ticking Noise from Rear Package Tray

Repair Procedure 3 (If Applicable) (Continued)

3. Eliminate the gap between the sheet metal panels.

A. The area of concern is serviceable from the top of the rear package tray sheet metal. See Figure 12 for adjustment area.

Figure 12. View From Inside of Vehicle Without Package Tray

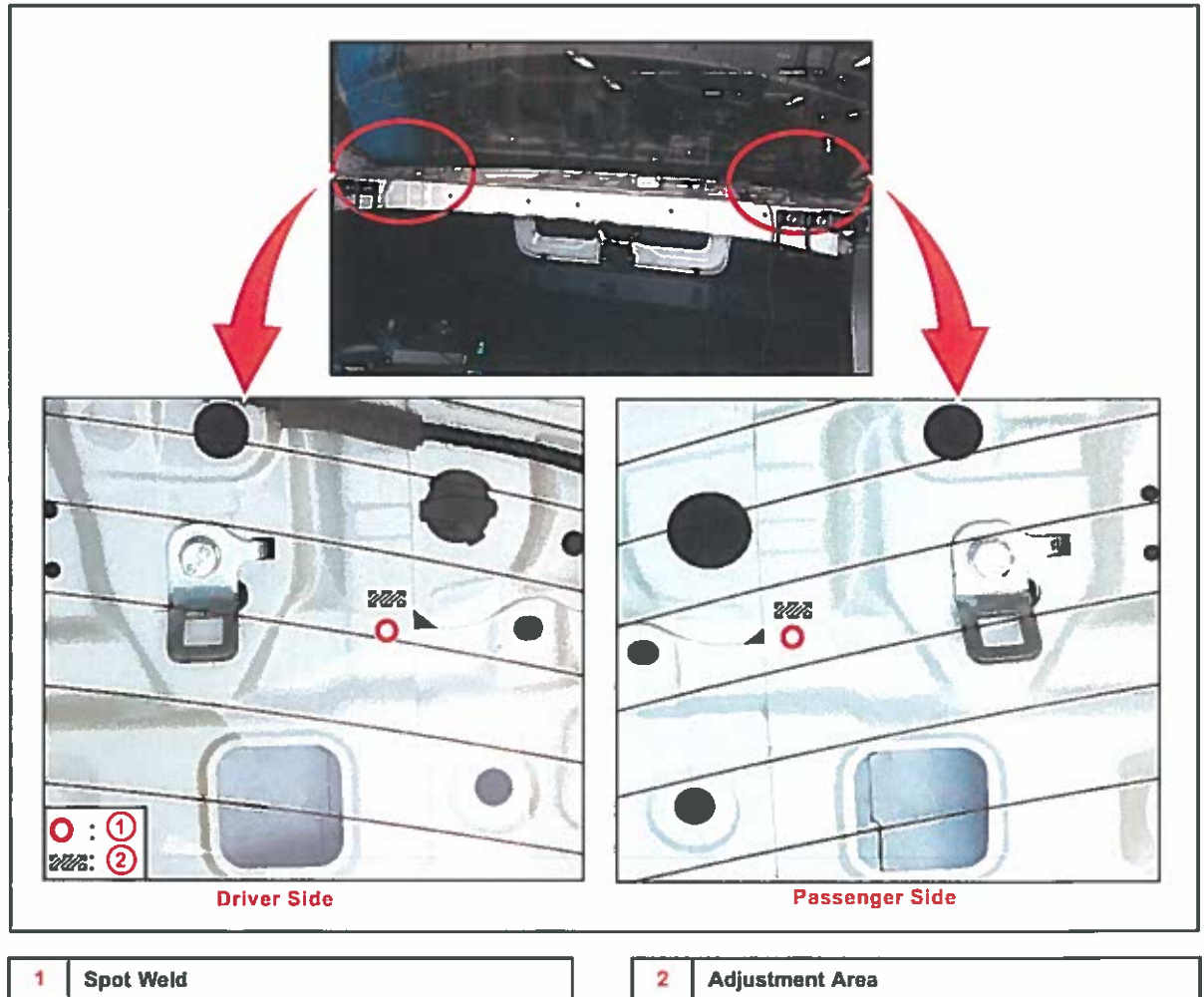

Ticking Noise from Rear Package Tray

Repair Procedure 3 (If Applicable) (Continued)

- B. From the inside of the vehicle, use a 5 mm Hex wrench (or equivalent) and the side face of a hammer to tap on the adjustment section as shown in Figure 11, 12 and in the video.

[Adjustment Video](#)

NOTICE

Damage to the rear glass may occur when adjusting the sheet metal, be careful NOT to hit the rear glass.

Figure 13. Close-up of Adjustment Point

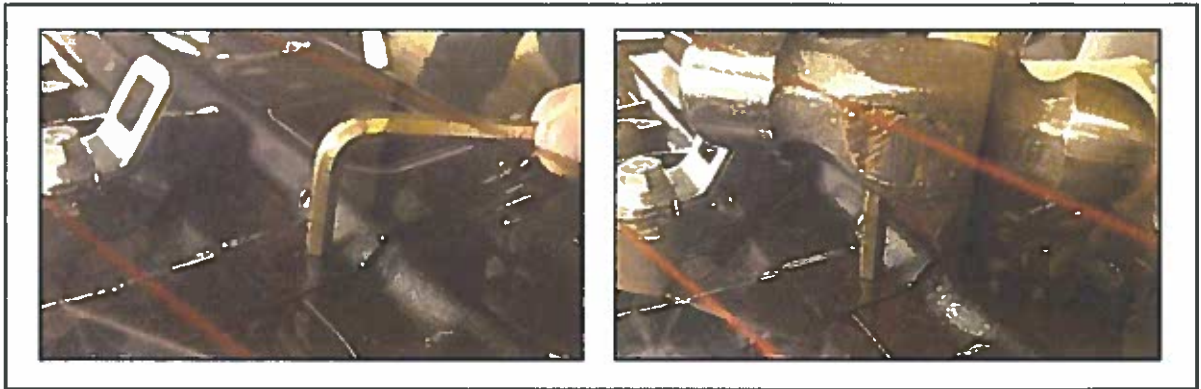

Figure 14. Adjustment Shown on Passenger Side



Ticking Noise from Rear Package Tray

Repair Procedure 3 (If Applicable) (Continued)

C. Confirm the gap between the sheet metal panels has been reduced.

4. Use Castle® Endura™ Heavy Duty Penetrating Grease between the sheet metal panels. Wipe away excess lubricant.

NOTICE

Do NOT use silicone-based lubricant because it can have adverse effects on electronic components.

Figure 15.



1	Spot Weld
2	Adjustment Area

5. Reassemble the Rear Package Tray.

A. Refer to TIS, applicable model and model year Repair Manual:

- 2013 FR-S:
Vehicle Interior – Door Lock – “Door Lock: Door Control Receiver: [Installation](#)”

6. Test drive the vehicle and confirm that the noise is no longer present from the areas included in Repair Procedure 1, 2, or 3.