

DCC Fuse Installation During PDS

Service Category General

Section Pre-Delivery Service

Market USA

Lexus Supports
ASE Certification 

Applicability

YEAR(S)	MODEL(S)	ADDITIONAL INFORMATION
2014	GS350, GS450H	

Introduction

To minimize battery discharge during transportation and storage, the DCC fuse (20A) has been removed at the assembly plant, and temporarily stored in the blank space of the fuse block in the engine compartment.

During Pre-Delivery Service (PDS), reinstall the DCC fuse into its original location.

Warranty Information

OP CODE	DESCRIPTION	TIME	OFP	T1	T2
N/A	Not Applicable to Warranty	–	–	–	–

DCC Fuse Installation During PDS

Installation Procedure

1. Remove the DCC fuse (20A) from the blank space of the fuse block in the engine compartment and install it in the location shown in Figure 1 during Pre-Delivery Service (PDS).

Figure 1.

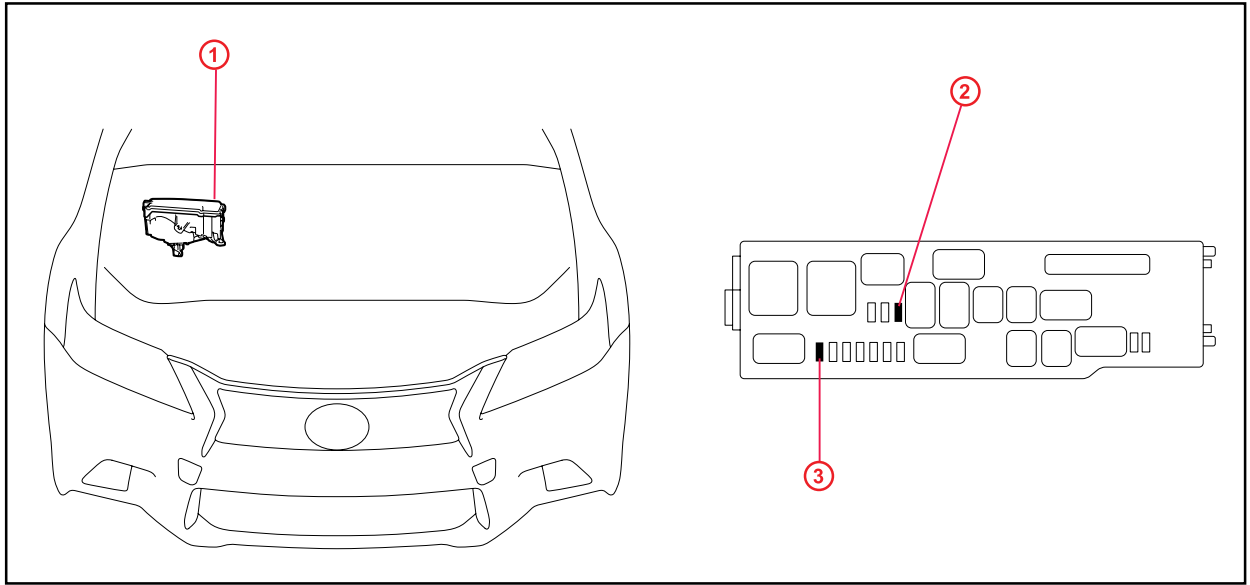

1	Relay Block
2	Remove this DCC Fuse

3	Install DCC Fuse Here
---	-----------------------

NOTE

- Removing the DCC fuse cuts OFF power sources relating to the DOME and MPX-B.
- While the vehicle is stored at the dealership, disconnect the negative (-) battery terminal to prevent battery discharge. Refer to Service Bulletin No. [PG001-06](#), "Battery Maintenance for In-Stock Vehicles & Pre-Delivery," for battery maintenance information.