



Countries:	AUSTRALIA, BRAZIL, CANADA, UNITED STATES, MEXICO, PUERTO RICO, SOUTH AFRICA	Document ID:	IK1500005
Availability:	ISIS, FleetSIS	Revision:	5
Major System:	FUEL SYSTEMS	Created:	11/16/2006
Current Language:	English	Last Modified:	12/23/2013
Other Languages:	Français , Español ,	Author:	Frank Amstadt
Viewed:	10856		

[Less Info](#)

Hide Details

Coding Information

Copy Link 	Copy Relative Link 	Bookmark View My Bookmarks	Add to Favorites 	Print 	Provide Feedback 	Helpful 2170	Not Helpful 2537
----------------------	-------------------------------	--	-----------------------------	------------------	-----------------------------	----------------------------	--------------------------------

Title: Dual Fuel Tank Transfer Pump System With Two Wire Pump Troubleshooting

Applies To: HPV with Feature Code: 595192

This Article applies to the models listed above with two wire fuel transfer pumps.

Trucks built after the above referenced date are equipped with two wire fuel transfer pumps that rely entirely on the ESC for their activation. The dual tank with transfer pump feature on HPV vehicles is designed to transfer fuel from the storage tank to the draw tank under strict guidelines and fuel level conditions. The ESC reads the fuel levels in both tanks and "filters" these readings to account for sloshing fuel and to assure that the draw tank is not overfilled and the supply tank is not emptied. The information provided in this article will help the technician use DLB to understand and answer two basic questions: Does the transfer pump move fuel from the storage tank into the draw tank, and if not what is the proper procedure to isolate and troubleshoot the problem?

[For 2007 and later models, click here.](#)

[For ProStar circuit diagrams, click here S08302.](#)

[For 2007 and later HPV, click here S08322.](#)

Service procedure

As previously mentioned, the ESC controls the fuel transfer pump and uses specific rules and conditions to determine when to turn on the transfer pump. Some of the more basic conditions that must be met before the pump is energized are:

1. No faults (open or shorted) can be active on either of the fuel sensors.
2. ESC must see engine RPM.
3. Storage tank must be at or above the 20% level.
4. Draw tank must be below 80%.
5. Draw tank fuel level must be at 12% (+/- 6%) below the storage tank fuel level.

Because there are various conditions when the tanks are very full or very empty the exact fuel pump control parameters can vary, this procedure is written to provide the technician with a standard test procedure to be followed in verifying the capability of the fuel transfer system. Passing these tests assure that the system is performing as designed and will provide the customer with a system that equalizes the fuel levels of the vehicle's two tanks while providing a fuel system without a fuel crossover line.

WARNING:

Do not perform the following test procedures if the draw tank (Fuel Sensor 1 Signal) has a fuel level above 80%. Failure to heed this warning could result in overfilling the draw tank, spilling fuel, and causing a hazardous waste spill or a fire hazard.

WARNING:

To avoid property damage, personal injury, or death, park the vehicle on a flat level surface, set the parking brake, and place the vehicle's transmission in neutral prior to beginning diagnostics and/or starting the engine.

CAUTION:

Do not perform the following test procedures if the storage tank (Fuel Sensor 2 Signal) has a fuel level below 10%. Failure to heed this caution could result in running the transfer pump without fuel and causing damage to the pump.

Verify Fuel Senders and Wiring

The following table shows the draw and storage tank positions on the various generations of truck models. Use the table to determine the fuel tank location where sensor 1 (draw) should be and where sensor 2 (storage) should be.

Models with Dual Tanks and Fuel Transfer Pump	Pre 03/01/04 Draw Tank	Post 03/01/04 Draw Tank	Pre 03/01/04 Storage Tank	Post 03/01/04 Storage Tank	Pre 03/01/04 Pump Location	Post 03/01/04 Pump Location
42/43/4400	RT	RT	LT	LT	Rt rail	Rt rail
73/74/75/8500	RT	<i>*LT</i>	LT	<i>*RT</i>	Rt rail	<i>*Xmsn Housing</i>
8600	LT	LT	RT	RT	Xmsn Housing	Xmsn Housing
7600	LT	LT	RT	RT	Lt rail	<i>*Xmsn Housing</i>
<p>* Trucks built after 03/01/2004. Changes to models are highlighted in italics.</p>						

1. Hook up EZ-TECH to the vehicle's 9-way diagnostic connector.
2. Open DLB and open a new "Dual Fuel Tanks.dls" session to monitor the parameters necessary to troubleshoot the dual fuel tank transfer pump function. The Watched Signals are shown in Figure 1.

NOTE:

The actual fuel sensor readings are displayed as Fuel Sensor 1 Signal (draw) and Fuel Sensor 2 Signal (storage). The ESC conditions these signals over time to allow for fuel sloshing and other transitional effects. The ESC looks at the conditioned signals (Fuel Draw Level and Fuel Storage Level) and uses these values to determine whether or not the fuel transfer pump should be activated. The ESC also conditions the Fuel Sensor 1 Signal and transmits a conditioned signal to be used by the instrument cluster fuel gauge. The importance of this is that the ESC does not react to instant changes in the sensor signals; it waits until the conditioned signals meet the required parameters to activate or deactivate the transfer pump.

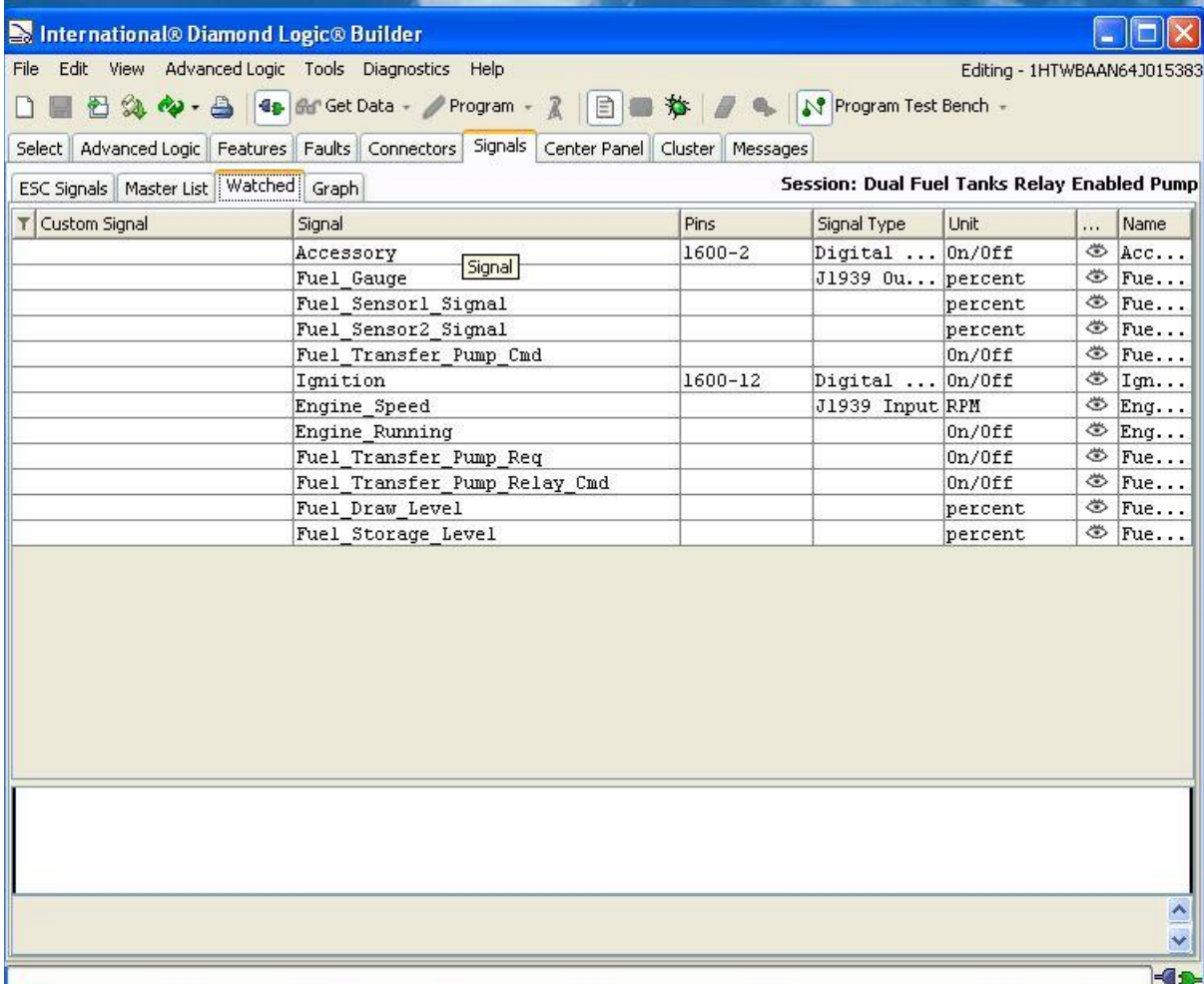

Custom Signal	Signal	Pins	Signal Type	Unit	...	Name
	Accessory	1600-2	Digital ...	On/Off	👁	Acc...
	Fuel_Gauge		J1939 Ou...	percent	👁	Fue...
	Fuel_Sensor1_Signal			percent	👁	Fue...
	Fuel_Sensor2_Signal			percent	👁	Fue...
	Fuel_Transfer_Pump_Cmd			On/Off	👁	Fue...
	Ignition	1600-12	Digital ...	On/Off	👁	Ign...
	Engine_Speed		J1939 Input	RPM	👁	Eng...
	Engine_Running			On/Off	👁	Eng...
	Fuel_Transfer_Pump_Req			On/Off	👁	Fue...
	Fuel_Transfer_Pump_Relay_Cmd			On/Off	👁	Fue...
	Fuel_Draw_Level			percent	👁	Fue...
	Fuel_Storage_Level			percent	👁	Fue...

Figure 1

- Verify that the draw tank is in the position listed in Table 1 above. The draw tank should have the fuel supply to the engine, the fuel return line (if equipped with a Cummins or Caterpillar), the transfer pump outlet, and the vent line going into the top of the tank.
- Turn the vehicle ignition ON and enter the DLB Diagnostic Mode to show the actual vehicle values as shown in Figure 2. Note that the conditioned signals (Fuel Draw Level and Fuel Storage Level) will always start out at 100% and 0% respectively. The ESC will not begin to condition these values, based on the sensor outputs, until it sees engine RPM.
- Disconnect the fuel level sender connector on the draw tank. If the DLB screen indicates that Fuel Sensor 1 has moved to "0" from its previous position then the wiring to sensor 1 is correct. Reconnect the fuel level sender and verify that the sender output and the actual fuel level in the draw tank are approximately the same.
- Disconnect the fuel level sender connector on the opposite side tank (should be storage) and verify that DLB shows Fuel Sensor 2 has gone to "0". Reconnect the fuel level sender and verify that the sender output and the actual fuel level in the storage tank are approximately the same.

Signal	Pins	Signal Type	Value	Unit	Status	Name
Accessory	1600-2	Digital I...	<input checked="" type="checkbox"/>	On/Off	0			Acc...
Ignition	1600-12	Digital I...	<input checked="" type="checkbox"/>	On/Off	0			Ign...
Engine_Speed		J1939 Input	0	RPM	32			Eng...
Engine_Running			<input type="checkbox"/>	On/Off	32			Eng...
Fuel_Transfer_Pump_Req			<input type="checkbox"/>	On/Off	0			Fue...
Fuel_Transfer_Pump_Relay_Cmd	4004-25	Relay Dri...	<input type="checkbox"/>	On/Off	0			Fue...
Fuel_Gauge		J1939 Output	59.2	percent	0			Fue...
Fuel_Sensor1_Signal			59.6	percent	0			Fue...
Fuel_Draw_Level			100	percent	0			Fue...
Fuel_Sensor2_Signal			53.6	percent	0			Fue...
Fuel_Storage_Level			0	percent	0			Fue...

Figure 2

7. If both fuel senders pass the above test it verifies that they are wired correctly and operating properly. If the draw tank is not Fuel Sensor 1 and the storage tank is not Fuel Sensor 2 the wiring is reversed and the transfer pump will not work. See Circuit Diagrams at end of procedure for proper connections.

Verify Transfer Pump Function

1. Verify the vehicle ignition is ON and the **engine not running** .
2. Using DLB left click on the "Fuel Transfer Pump Req" Value box and both the Fuel Transfer Pump Req and the Fuel Transfer Pump Relay Cmd boxes should show a check mark indicating ON.
3. Listen for the activation of the fuel transfer pump and verify that the pump inlet is coming from the storage tank and the output is going to the draw tank.
4. If the pump does not turn on then check the wiring to the ESC, the ESC output on pin 25 of Connector 4004, the pump relay as described in the Introduction of S082503, or the pump itself.
5. Left click the "Fuel Transfer Pump Req" padlock symbol and the padlock should open up and remove the checks from the "Fuel Transfer Pump Req" and the "Fuel Transfer Pump Relay Cmd" boxes, the transfer pump should now be off. See Figure 2.

WARNING:

Do not let the transfer pump run for an extended period. When the function is verified make sure you turn the transfer pump off by performing step 5. above! Failure to heed this warning could result in overfilling the draw tank, spilling fuel, and causing a hazardous waste spill or a fire hazard.

Verify The ESC Logic and Function

1. With the ignition ON and engine **not** running, insert "0" into the "Fuel Sensor 1 Signal" (draw tank) Value and "100" into the "Fuel Sensor 2 Signal" (storage tank). To insert values place the cursor over the value you want to change, double left click, type in the value wanted and hit "enter". Note that while the engine is not running the "Fuel Transfer Pump Relay Cmd" should be off and the DLB window should look like Figure 3.

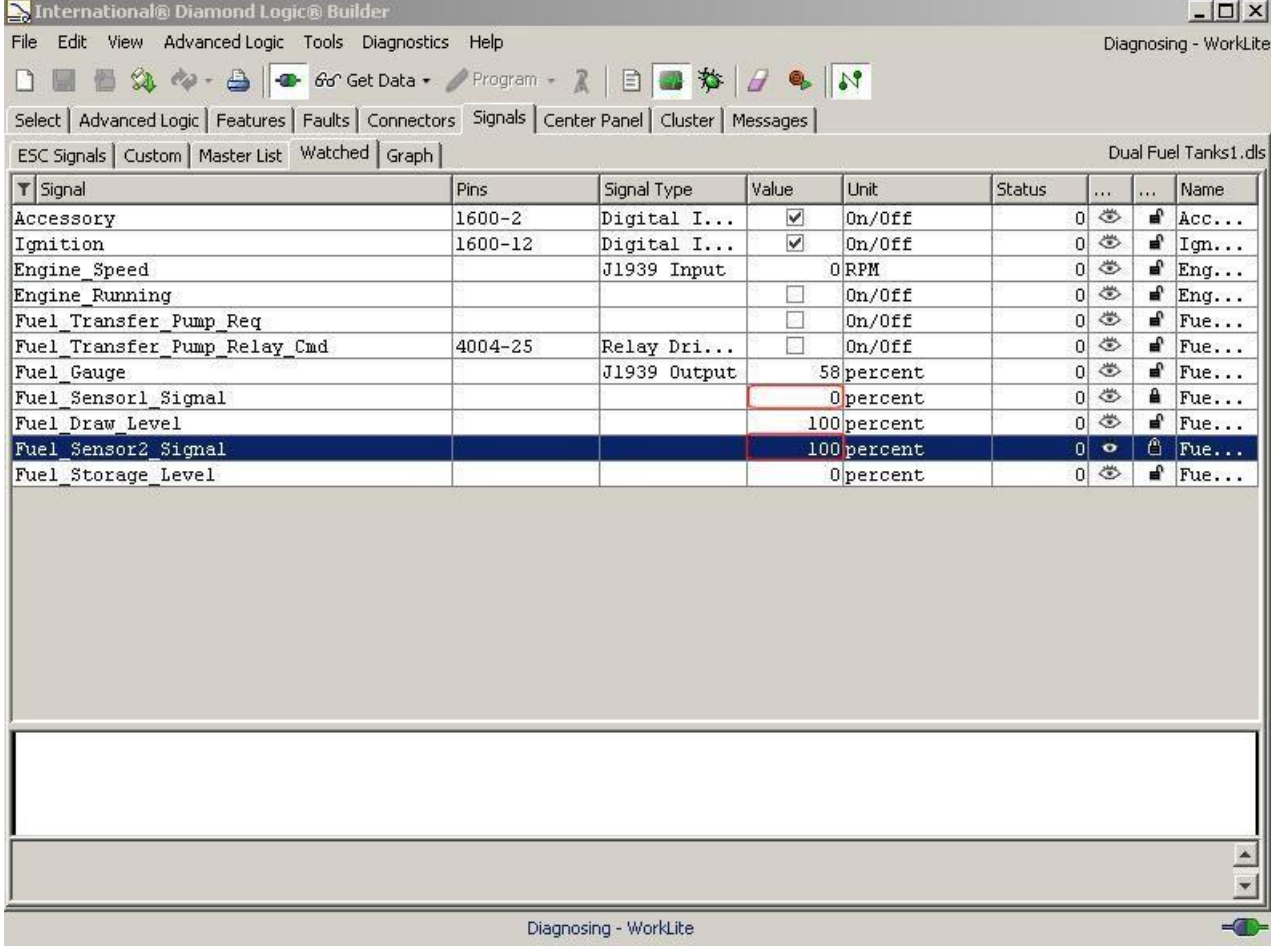

Signal	Pins	Signal Type	Value	Unit	Status	Name
Accessory	1600-2	Digital I...	<input checked="" type="checkbox"/>	On/Off	0			Acc...
Ignition	1600-12	Digital I...	<input checked="" type="checkbox"/>	On/Off	0			Ign...
Engine_Speed		J1939 Input		0 RPM	0			Eng...
Engine_Running			<input type="checkbox"/>	On/Off	0			Eng...
Fuel_Transfer_Pump_Req			<input type="checkbox"/>	On/Off	0			Fue...
Fuel_Transfer_Pump_Relay_Cmd	4004-25	Relay Dri...	<input type="checkbox"/>	On/Off	0			Fue...
Fuel_Gauge		J1939 Output		58 percent	0			Fue...
Fuel_Sensor1_Signal			0	percent	0			Fue...
Fuel_Draw_Level			100	percent	0			Fue...
Fuel_Sensor2_Signal			100	percent	0			Fue...
Fuel_Storage_Level			0	percent	0			Fue...

Figure 3

2. Start the vehicle's engine. Note that the Engine RPM should be indicated and the Engine Running value box should be checked. Within 2 minutes the "Fuel Transfer Pump Req" and the "Fuel Transfer Pump Relay Cmd" on the DLB session window should turn ON (check in Value box) as shown in Figure 4. Note that Figure 4 shows the Fuel Storage Level at 94% and the Fuel Draw Level at 0.4% which meets the parameters for pump command to turn the transfer pump on. Remember the actual ESC command to turn the pump on will occur shortly after the Fuel Draw Level Value falls below the Fuel Storage Level as the two levels are conditioned by the ESC when it interprets the Fuel Sensor 1 Signal and the Fuel Sensor 2 Signal. The ESC does not activate the transfer pump based on the Fuel Sensor signals; it reacts to the **conditioned signals only** - "Fuel Draw Level" and "Fuel Storage Level".

Signal	Pins	Signal Type	Value	Unit	Status	Name
Accessory	1600-2	Digital I...	<input checked="" type="checkbox"/>	On/Off	0			Acc...
Ignition	1600-12	Digital I...	<input checked="" type="checkbox"/>	On/Off	0			Ign...
Engine_Speed		J1939 Input	614.25	RPM	0			Eng...
Engine_Running			<input checked="" type="checkbox"/>	On/Off	0			Eng...
Fuel_Transfer_Pump_Req			<input checked="" type="checkbox"/>	On/Off	0			Fue...
Fuel_Transfer_Pump_Relay_Cmd	4004-25	Relay Dri...	<input checked="" type="checkbox"/>	On/Off	0			Fue...
Fuel_Gauge		J1939 Output	59.2	percent	0			Fue...
Fuel_Sensor1_Signal			0	percent	0			Fue...
Fuel_Draw_Level			0.4	percent	0			Fue...
Fuel_Sensor2_Signal			100	percent	0			Fue...
Fuel_Storage_Level			94	percent	0			Fue...

Figure 4.

3. When the ESC Logic and Function have been verified, turn off the engine and left click the locked padlock symbols of Fuel Sensor 1 Signal and Fuel Sensor 2 Signal. Once the padlocks symbols are opened sensor 1 and sensor 2 values should return to the actual sensor readings.

WARNING:

Do not let the transfer pump run for an extended period. When the function is verified make sure you turn the transfer pump off by performing step 3. above! Failure to heed this warning could result in overfilling the draw tank, spilling fuel, and causing a hazardous waste spill or a fire hazard.

4. Since the fuel sensors, their wiring, and the transfer pump function has been verified, if the logic test fails to turn on pin 25 of connector 4004 either the ESC is not seeing the engine RPM or the ESC is at fault.

5. If the transfer pump fails to energize in Procedure #2 above, check the cluster to see if the tech is working. The cluster uses the same tech message that the ESC uses to enable the fuel transfer pump.

6. If the ESC is seeing the engine RPM and still does not activate the transfer pump under the above conditions, check Features and make sure that the "Dumb Pump" relay drive feature 00595192 is enabled and that 00595054 is disabled.

7. If the above procedure is followed and the transfer pump will not activate, the ESC or its software are at fault.

CIRCUIT DIAGRAMS

4200-4400 DUAL TANK

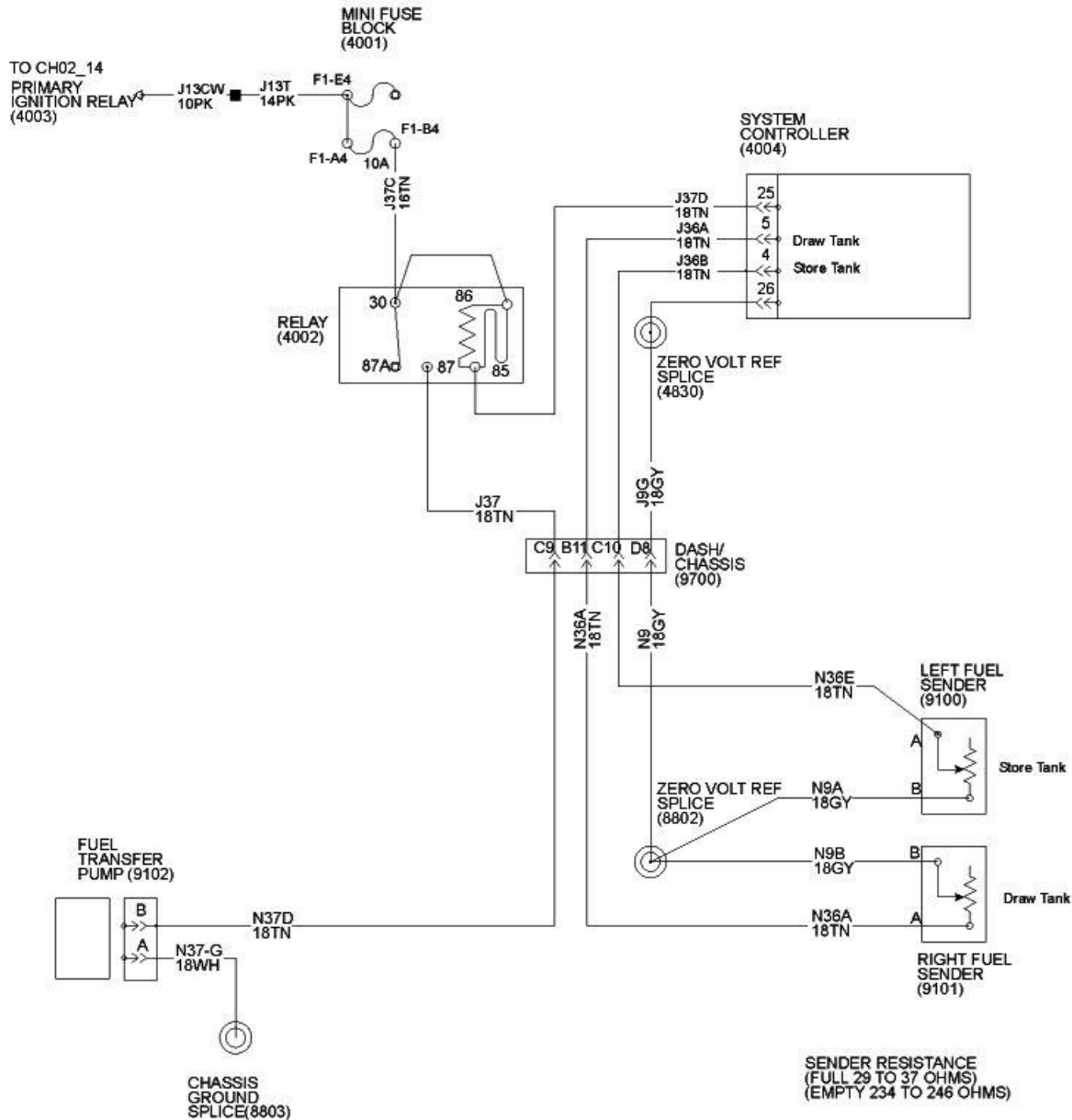

Figure 5

7300-7600, 8500 DUAL TANK POST 3/1/04

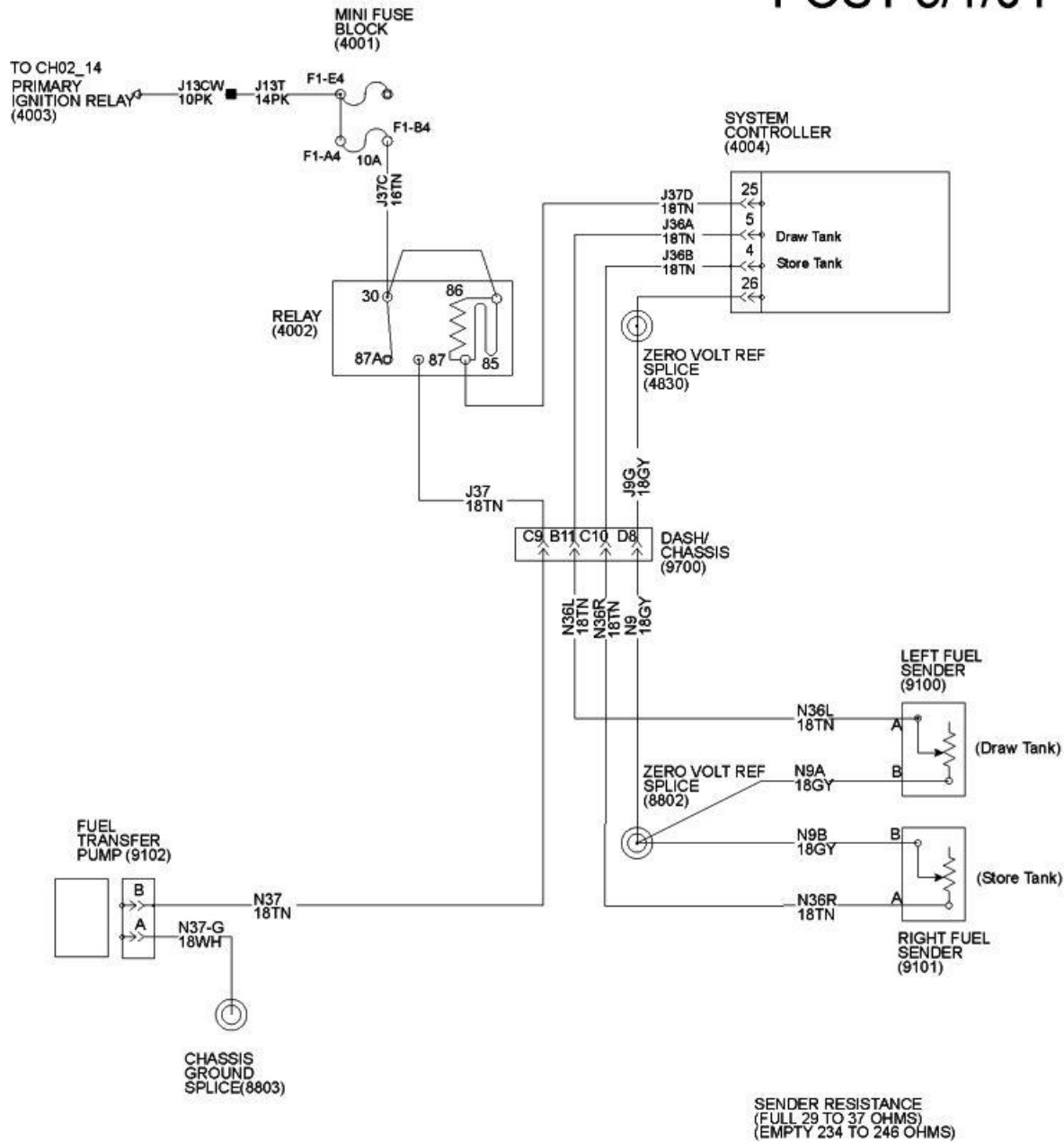

Figure 6

8600

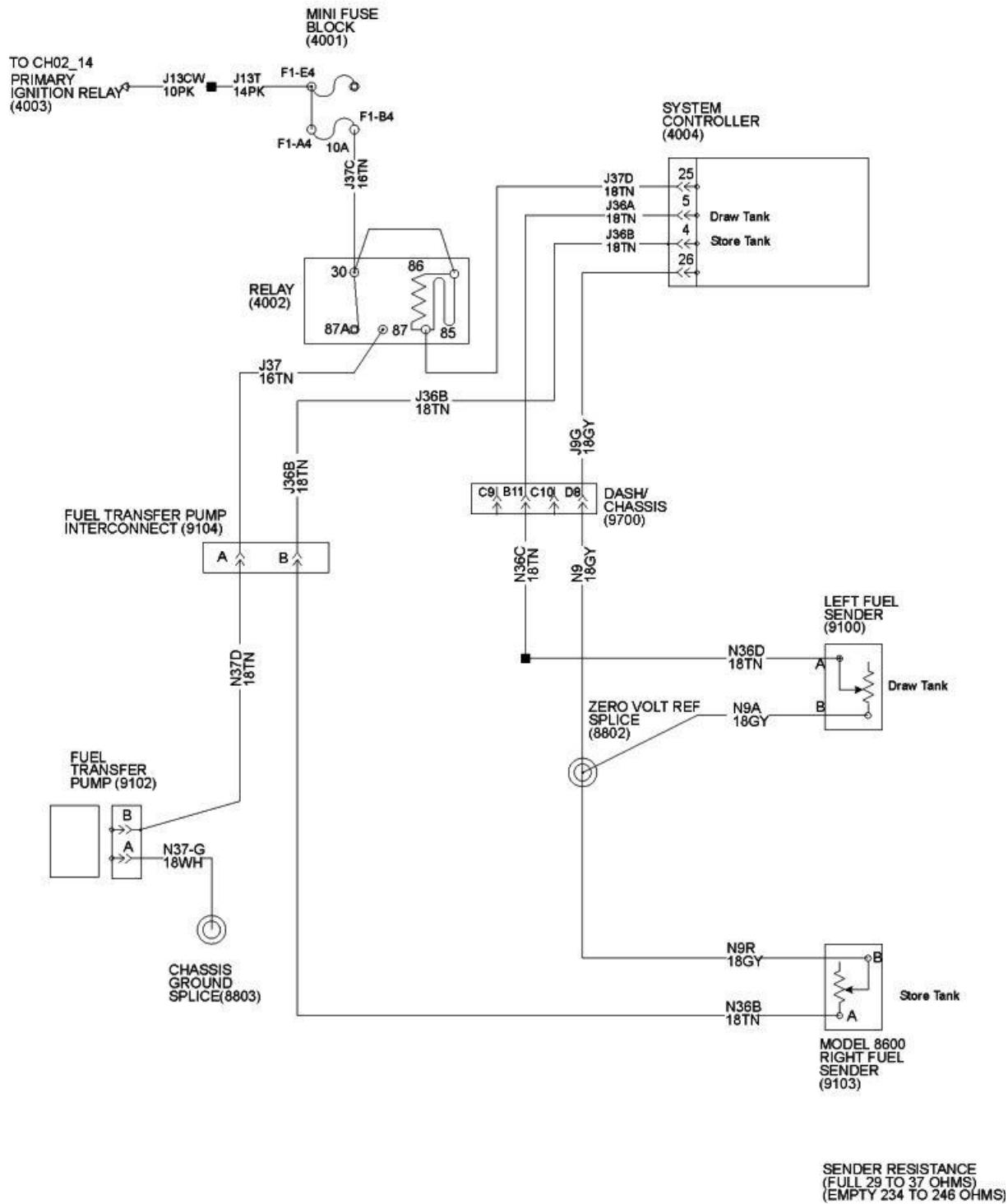

Figure 7

Hide Details

Feedback Information

Viewed: 10855
 Helpful: 2170
 Not Helpful: 2537

No Feedback Found

Copyright © 2014 Navistar, Inc.