



Countries: CANADA, UNITED STATES, PUERTO RICO **Document ID:** IK1300138
Availability: ISIS, FleetISIS **Revision:** 4
Major System: TRANSMISSION **Created:** 8/10/2013
Current Language: English **Last Modified:** 12/9/2013
Other Languages: NONE **Author:** Matthew Boyer
Viewed: 362

[Less Info](#)

Hide Details

Coding Information

Copy Link 	Copy Relative Link 	Bookmark View My Bookmarks	Add to Favorites 	Print 	Provide Feedback 	Helpful 6	Not Helpful 2
----------------------	-------------------------------	--	-----------------------------	------------------	-----------------------------	-------------------------	-----------------------------

Title: TerraStar Transfer Case Diagnostic and Operational Information

Applies To: TerraStar 4x4 Models

Description

TerraStar 4x4 model vehicles are built with a FABCO TC-28 transfer case with 4 feedback switches and 2 electric actuators. The body controller monitors the feedback switches to regulate when it grounds each one of the 4 relays that control the amperage and polarity to each of the 2 electric actuators. The transfer case has 3 modes, 4x2 high, 4x4 high, and 4x4 low.

Interlocks To Change Ranges

To shift the transfer case from 4X2 high mode to 4x4 high mode, the following interlocks must be met:

- Key is in the run position
- Engine speed is above programmable parameter 3047, Engine_Operating_Threshold. Default setting is 300 RPM
- Vehicle speed is below programmable parameter 2812, Axle_Engage_Threshold. Default setting is 24 MPH
- Axle differential speed is below programmable parameter 3052, FR2RR_Vel_Diff_ABS_Threshold. Default setting is 0.93 MPH
- Front axle switch is in the upper position and has a good status

To shift the transfer case from 4x4 high mode to 4x4 low mode, the following interlocks must be met:

- Transfer case is in 4x4 high mode
- Vehicle speed is below programmable parameter 3045, Range_Engage_Threshold. Default setting is 3 MPH
- Transmission is in the neutral range
- Service brake is depressed
- Key is in the run position
- Engine speed is above programmable parameter 3047, Engine_Operating_Threshold. Default setting is 300 RPM
- Range switch is in the lower position and has a good status

When shifting from 4x4 high to 4x4 low mode, the front axle indicator lamp in the front axle switch will flash. This is normal operation.

DLB Template

Click [HERE](#) for the DLB template for diagnosing this.

Signal Descriptions

Signal	B/C Pin	Transfer case Mode	Description
Xfer_Case_4x4_Cmd	1601-E13	N/A	This is the ground command to the 4x4 relay
Xfer_Case_4x2_Cmd	1601-E9	N/A	This is the ground command to the 4x2 relay
Xfer_Case_High_Cmd	1601-F4	N/A	This is the ground command to the high range relay
Xfer_Case_Low_Cmd	1601-F5	N/A	This is the ground command to the low range relay
Transfer_Case_Front_Axle_Disengaged	1602-F11	Front axle is not engaged when checked in DLB	This is the signal from switch SW1, indicating the transfer case position.
Transfer_Case_Front_Axle_Engaged	1602_F13	Front axle is engaged when checked in DLB	This is the signal from switch SW2, indicating the transfer case position.
Transfer_Case_Driveline_Engaged_Low	1602-F8	Transfer case is in low range when checked in DLB	This is the signal from switch SW3, indicating the transfer case position.
Transfer_Case_Driveline_Engaged_High	1602-F9	Transfer case is in high range when checked in DLB	This is the signal from switch SW4, indicating the transfer case position.

Operational Values

Transfer Case Range	SW1	SW2	SW3	SW4
4x2 High	Closed	Open	Open	Closed

4x4 High	Open	Closed	Open	Closed
4x4 Low	Open	Closed	Closed	Open

Fault Codes

Signal	B/C Pin	SPN	FMI	Description	Action
xfer_Case_4x4_cmd xfer_Case_4x2_cmd Transfer_Case_Front_Axle_Engaged Transfer_Case_Front_Axle_Disengaged	1601_E13 1601_E9 1602_F13 1602_F11	4043	6	Transfer Case Front Driveline Actuator Transfer Case Front Driveline Solenoid Short To Ground	This indicates there is a short to ground in either of the transfer case front axle mode circuits
Transfer_Case_Front_Axle_Disengaged	1602_F11	4043	3	Transfer Case Front Driveline Actuator Fault Via Transfer Case Front Axle Disengaged	Open from SW1 to the body controller, body controller expects transfer case to be in 4x2 high range
Transfer_Case_Front_Axle_Engaged	1602_F13	4043	4	Transfer Case Front Driveline Actuator Fault Via Transfer Case Front Axle Engaged	Open from SW2 to the body controller, body controller expects transfer case to be in 4x4 high range
Transfer_Case_Driveline_Engaged_Low	1602_F8	4045	3	Transfer Case Low Range Actuator Fault Via Transfer Case Driveline Engaged Low limit switch	Open from SW3 to the body controller, body controller expects transfer case to be in 4x4 high range
Transfer_Case_Driveline_Engaged_High	1602_F9	4044	3	Transfer Case High Range Actuator Fault Via Transfer Case Driveline Engaged High limit switch	Open from SW4 to the body controller, body controller expects transfer case to be in 4x4 low range
xfer_Case_Low_cmd xfer_Case_High_cmd Transfer_Case_Driveline_Engaged_Low Transfer_Case_Driveline_Engaged_High	1601_F5 1601_F4 1602_F8 1602_F9	4044	6	Transfer Case High Range Actuator Transfer Case High Range Solenoid Short To Ground	This indicates there is a short to ground in either of the transfer case range circuits
Transfer_Case_Front_Axle_Engaged Transfer_Case_Front_Axle_Disengaged Transfer_Case_Driveline_Engaged_Low Transfer_Case_Driveline_Engaged_High	1602_F13 1602_F11 1602_F8 1602_F9	3645	5	Transfer case status All Limit switches for Electronic transfer Case are open	All Limit switches for Electronic transfer Case are open
Transfer_Case_Front_Axle_Engaged Transfer_Case_Front_Axle_Disengaged	1602_F13 1602_F11	4043	7	Transfer Case Front Driveline Actuator System not responding Fault with Front axle engagement motor	The body controller is sending a command either the axle engagement or disengagement relay, but there is no status change from either SW1 or SW2
Transfer_Case_Driveline_Engaged_Low Transfer_Case_Driveline_Engaged_High	1602_F8 1602_F9	4044	7	Transfer Case High Range Actuator System not responding Fault with Driveline Range(High/Low) engagement motor	The body controller is sending a command either the low or high range relay, but there is no status change from either SW3 or SW4
ABS Module		3645	9		This is a fault code from the ABS module indicating the ABS does not know which range the transfer case is in

Switch Locations

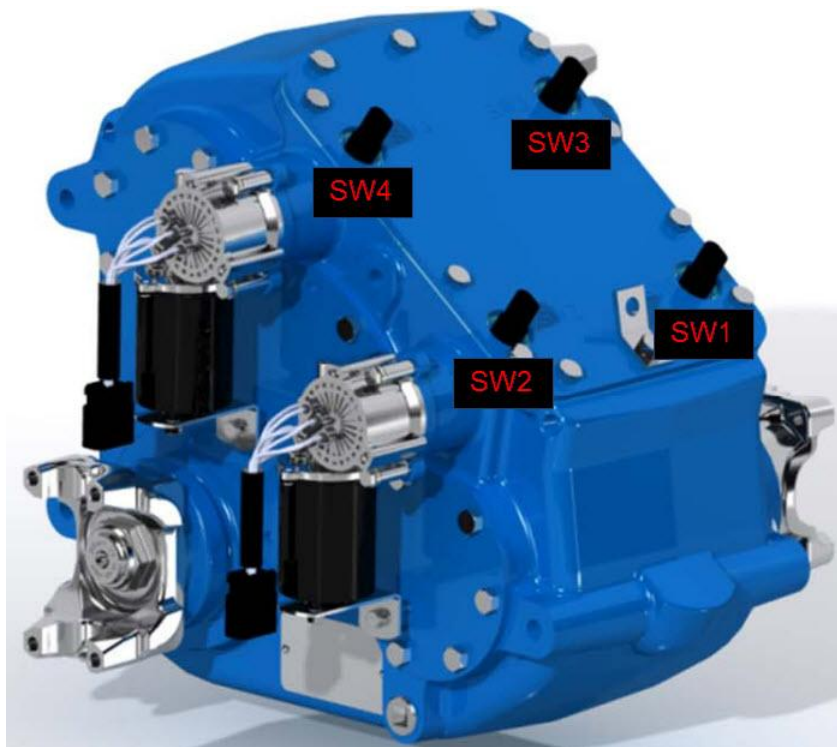

Troubleshooting

When the transfer case is in any range, the switch that corresponds with that location will be closed, completing the feedback circuit to the body controller. The high and low range switches should never both be closed at the same time. The front axle engaged and front axle disengaged switches should never both be closed at the same time either.

The first step to diagnosing the system is to understand which range the transfer case currently is in. There are two ways to figure this out. The first way is to place the vehicle in neutral with the engine off and wheels chocked, and comparing the input and output rotations of each shafts are they are being turned by hand in comparison to each other. The second is to drive the vehicle and see if the speedometer is accurate, and if the vehicle is capable of reaching highway speeds. The transfer case low range is a 2.2:1 underdrive. This means that when the transfer case is in low range, for every 2.2 turns of the output shaft from the transmission to the transfer case, the driveshafts that connect to the axles turn one time. Once the transfer case range is understood, this should be compared to the reading of the feedback switches in DLB with the key on. The table above gives signal descriptions for each range. If the feedback signals do not match the current position of the transfer case, the body controller will not send a signal for the transfer case to shift.

Circuit Diagram

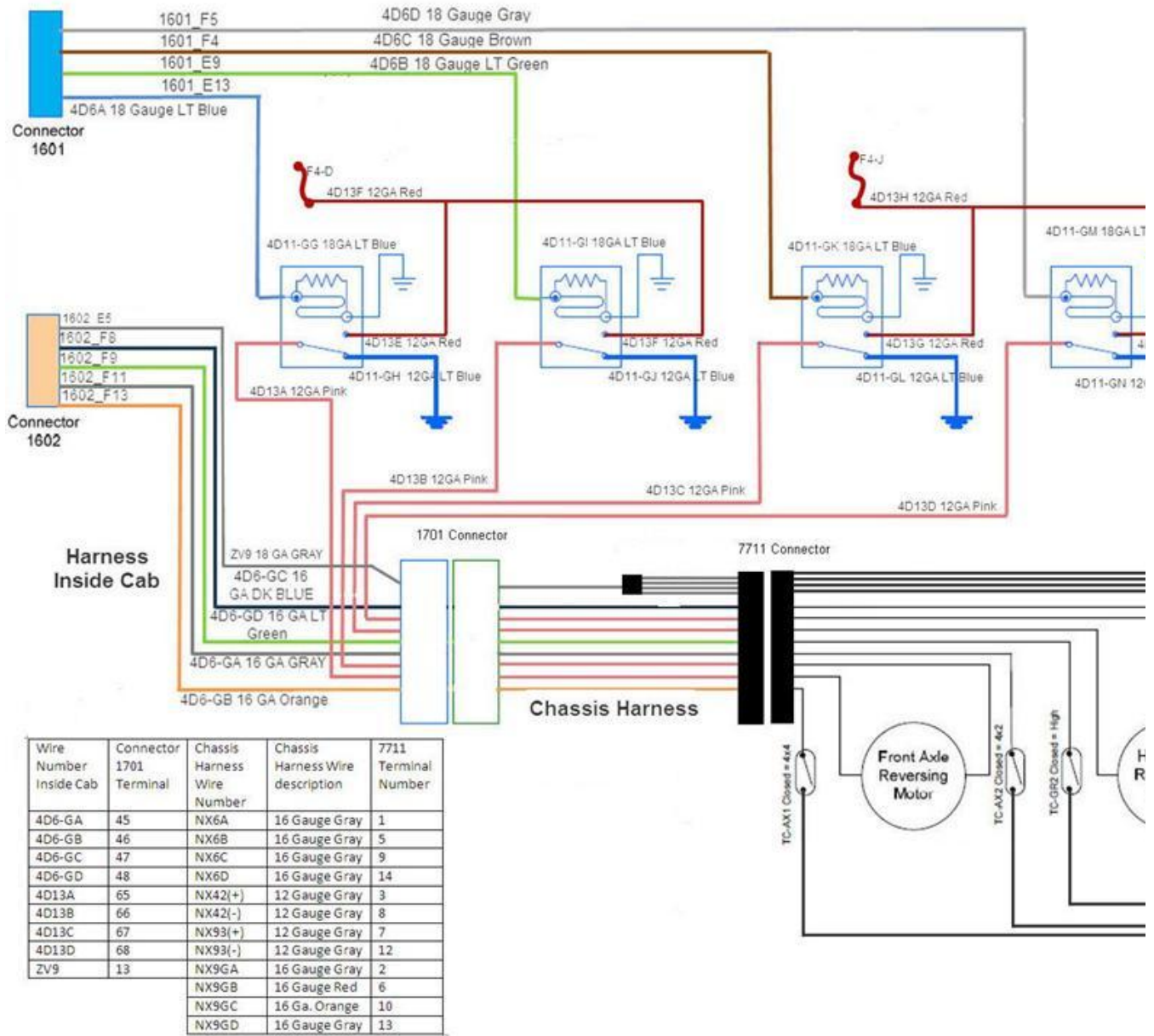

Transfer Case Mounted Wiring Harness Diagram

Click [HERE](#) for the transfer case mounted wiring diagram

Transfer Case Information

The parts and service manual for the FABCO TC-28 transfer case can be obtained by clicking [HERE](#).

Hide Details
Feedback Information

Viewed: 361
 Helpful: 6
 Not Helpful: 2

No Feedback Found