



Service Bulletin

PRELIMINARY INFORMATION

Subject: Intermittent Unwanted Trunk Opening While Vehicle is Parked

Models: 2010-2013 Buick LaCrosse
2011-2013 Buick Regal
2012-2013 Buick Verano
2011-2013 Chevrolet Cruze
2012-2013 Chevrolet Sonic (4 Door Sedan Only)
2013 Chevrolet Malibu

Condition/Concern

Some customers may comment on unwanted opening of the trunk without pressing any of the release buttons while the vehicle is parked. Although the trunk is unlatched while parked, the owner may not observe the trunk open until they begin to drive the vehicle. This may also be accompanied with a "Trunk Open" message in the DIC.

This condition may be caused by the trunk release button on the remote transmitter being pressed inadvertently while the transmitter is in their pocket or purse.

Recommendation/Instructions

Replace the KR95B Rear Compartment Lid Unlatch Relay with a "Two Shot Relay", GM P/N 19119267, using the applicable procedure below. When installed, the remote transmitter (key fob) trunk release button, the exterior rear compartment lid release switch (touch pad) or the interior rear compartment lid release switch must be pressed twice within three seconds to release the trunk.

For LaCrosse, Regal (2011 Germany Built (RPO RUE)), Verano, Cruze and Malibu

Remove the KR95B Rear Compartment Lid Unlatch Relay located in the X51A Instrument Panel Fuse Block and install the "Two Shot Relay."

For Regal (2011 Oshawa Built (RPO OSH), 2012-2013) and Sonic

The rear compartment lid unlatch relay is part of the printed circuit board in the relay/fuse block and not serviceable separately. Installation of an external relay circuit to bypass the feed to the trunk release control will be required. Install the "Two Shot Relay" adjacent to the BCM and attach a tag to the relay and mark with "Two Shot Trunk Relay per Bulletin PI0924." For future diagnosis for an inoperative trunk release, this relay installation will be identified before a BCM is replaced.

1. Label the four leads of connector, P/N 12126045 as indicated below.
2. Connect the connector to the new relay, P/N 19119267.
3. Locate circuit 6188 (trunk release control) at the BCM following service information. Cut the wire and splice the BCM and relay side of the circuit as shown below.
4. Connect wire fused, unswitched power and ground as shown below.

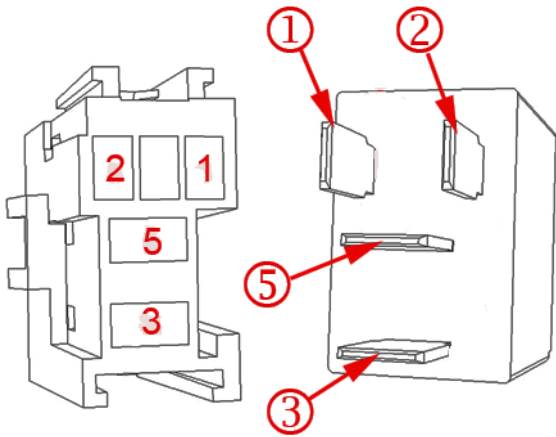
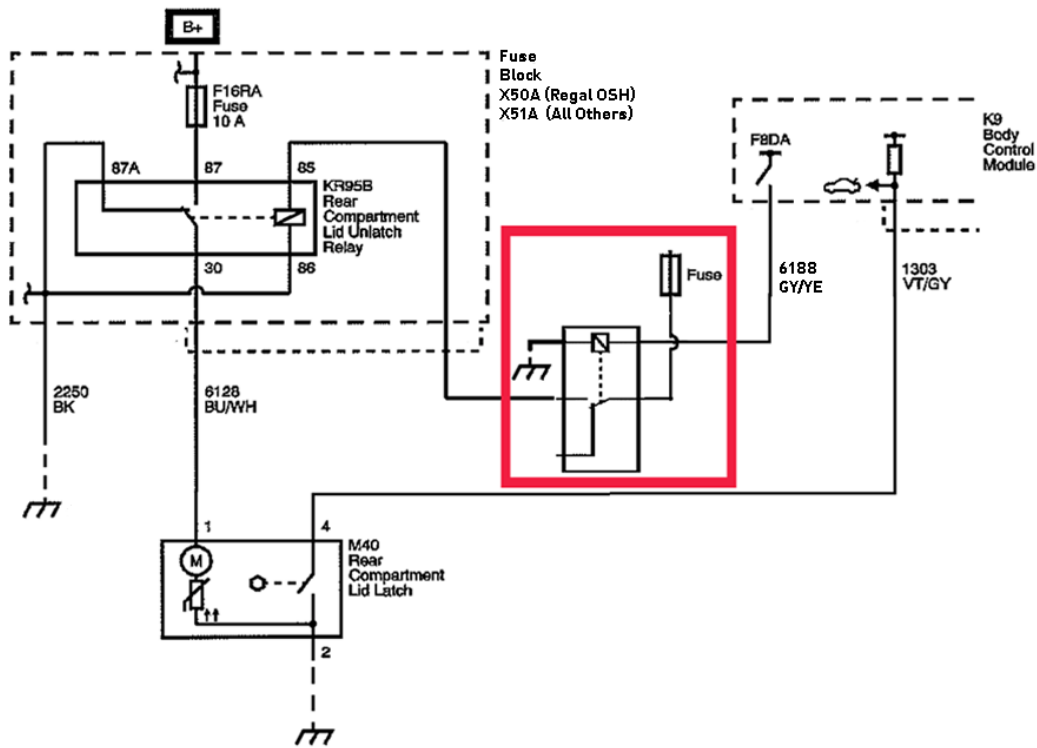

1. BCM Circuit No. 6188
2. Ground
3. Relay Circuit No. 6188
5. Fused 12V Power

Customer Information

Please communicate to the customer that once this repair is completed, the remote transmitter (key fob) trunk release button, the exterior rear compartment lid release switch (touch pad) or the interior rear compartment lid release switch must be pressed twice within three seconds to release the trunk. Please share this information with the customer, including a copy of this message.

Parts Information

Part Number	Description	Qty
19119267	Relay, Rear Compartment Lid Release (2-Shot Trunk Release Relay)	1

12126045 (Regal, Sonic Only)	Connector	1
---------------------------------	-----------	---

Warranty Information

For vehicles repaired under warranty, use:

Labor Operation	Description	Labor Time
N9702* (LaCrosse, Regal (2011 Germany Built), Verano, Cruze and Malibu)	Installation of Two Shot Trunk Release Relay	0.3 hr
N9702* (Regal (2011 Oshawa Built, 2012-2013) and Sonic)	Installation of Two Shot Trunk Release Relay	1.0 hr
*This is a unique labor operation for bulletin use only. It will not be published in the Labor Time Guide.		

GM bulletins are intended for use by professional technicians, NOT a "do-it-yourselfer". They are written to inform these technicians of conditions that may occur on some vehicles, or to provide information that could assist in the proper service of a vehicle. Properly trained technicians have the equipment, tools, safety instructions, and know-how to do a job properly and safely. If a condition is described, DO NOT assume that the bulletin applies to your vehicle, or that your vehicle will have that condition. See your GM dealer for information on whether your vehicle may benefit from the information.



WE SUPPORT VOLUNTARY TECHNICIAN CERTIFICATION