

Diagnostic Trouble Codes (DTCs), Low Oil Pressure
 D16
 VN, VT

FSB 221-011, Diagnostic Trouble Codes (DTCs), Low Oil Pressure

(November 2013)

Information

During long hard pull conditions, diagnostic trouble codes (DTCs) PID 100 FM1, SPN 100 FMI 1 or P252400 can log on certain VOLVO vehicles with D16 engines built from January 2007 to current production. If any of these DTCs occurs during the conditions described in this bulletin, with or without an engine shut down lamp, follow Guided Diagnostics for fault tracing.

Follow Guided Diagnostics fault tracing and verify the oil pressure readings with a manual gauge at various engine revolutions per minute (RPM). After verifying all checks are within specification, if the issue is still present and there are no obvious signs of oil dilution, replace the pressure reduction (relief) valve (purple) using the procedure below.

Service personnel: Please circulate, read and initial

Service Manager	Warranty Administrator	Workshop Foreman	Service Technicians						

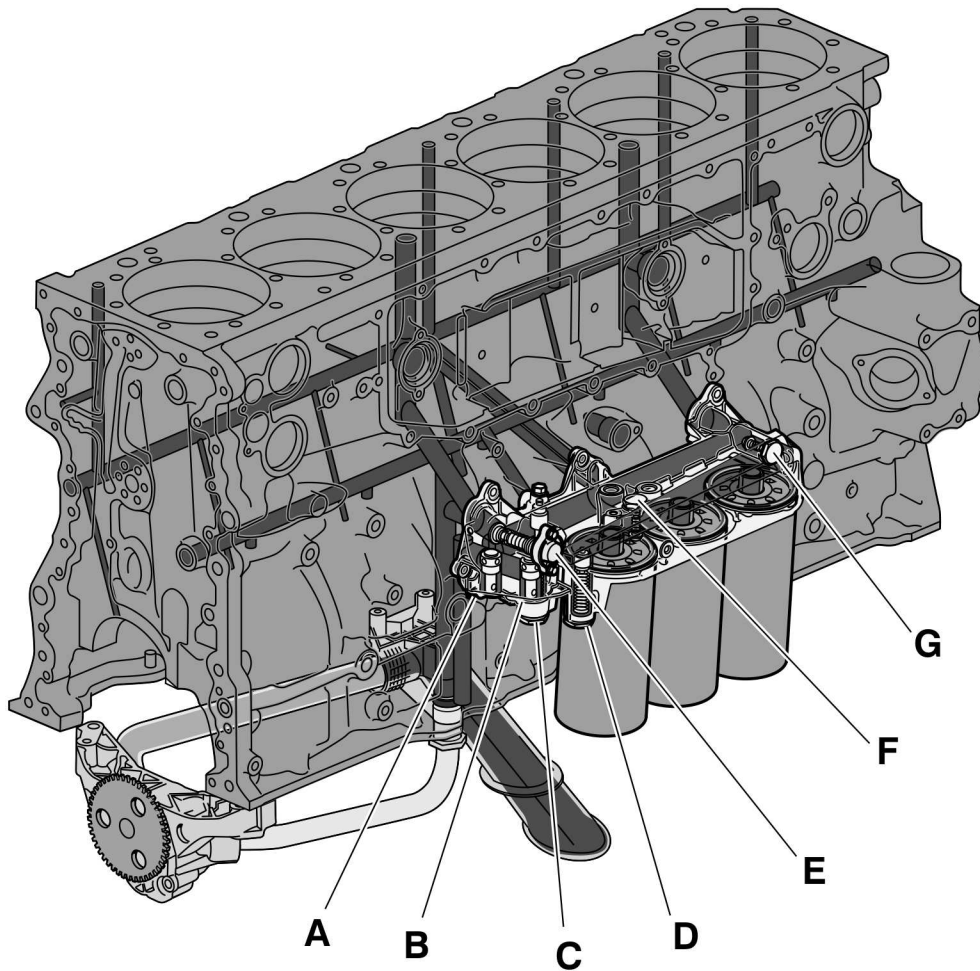

T2023373

A	Pressure Reduction (Relief) Valve, Purple
B	Regulating Valve
C	Control Valve for piston cooling
D	Opening Valve for piston cooling
E	Overflow Valve for oil cooler
F	Overflow Valve for the bypass filter
G	By-pass Valve for full-flow filter

Required Parts

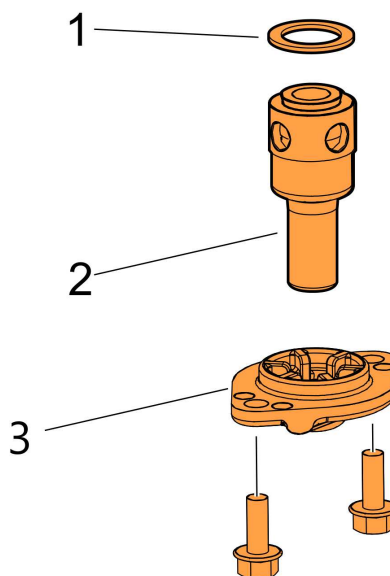

W2085522

Required Parts			
Item Number	Part Number	Description	Quantity
1	469846	O-Ring, Internal	1
2	22188378	Pressure Reduction (Relief) Valve, Purple	1
3	949659	O-Ring, Cover	1

Procedure

You must read and understand the precautions and guidelines in Service Information, Function Group 20, "Engine Safety Practices" before performing this procedure. If you are not properly trained and certified in this procedure, ask your supervisor for training before you perform it.



DANGER

Do not attempt to repair or service this vehicle without having sufficient training, the correct service literature and the proper tools. Failure to follow this could make the vehicle unsafe and lead to serious personal injury or death.

- 1 Secure the vehicle for service by parking it on a flat level surface, applying the parking brake, chocking the rear wheels, and placing the transmission in neutral.
- 2 Disconnect all battery cables from the negative (ground) battery terminals to prevent personal injury from electrical shock and prevent damage to electrical components.
- 3 Remove and replace the pressure reduction (relief) valve in the oil filter housing with part number 22188378 and replace the internal O-ring with part number 469846. Tighten cover fasteners to 10 ± 2 Nm (88 ± 17 in-lbs).

Note: During installation of the reduction valve, the cover must be flat against the oil filter housing before the bolts are installed to ensure the valve is seated flush against the sealing surface.

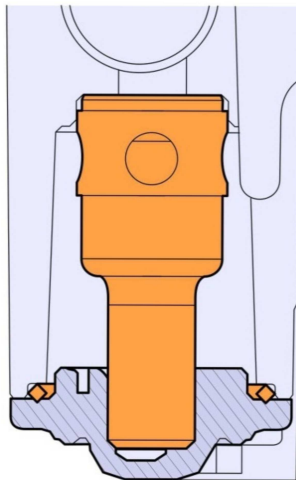

- 4 Reconnect all previously removed cables to the negative (ground) battery terminals.
- 5 Start engine, check for leaks and proper operation. Clear any DTC.

Reimbursement

This repair may be eligible for reimbursement if a product failure was experienced within time and mileage limits of the applicable Warranty coverage. Reimbursement is obtained via the normal claim handling process.	
Claim Type (used only when uploading from the Dealer Bus. Sys.)	W
Labor Code	
Primary Labor Code	22142-2-00 — 0.3 hrs.
Causal Part	3826265

VOLVO Trucks North America engages in a comprehensive program of testing and evaluating to provide the best possible product. VOLVO Trucks North America however, is not committed to, or liable for updating existing vehicles.