

Technical Service Bulletin



72 Rear center seat rattles and does not fold flat

72 13 11 2023324/3 October 21, 2013. Supersedes Technical Service Bulletin Group 72 number 13-08 dated September 10, 2013 for reasons listed below.

Model(s)	Year	VIN Range	Vehicle-Specific Equipment
Q5	2009 - 2010	All	Not Applicable

Condition

REVISION HISTORY		
Revision	Date	Purpose
3	-	Revised header data (Updated customer codes)
2	9/10/2013	Revised header data (Updated customer codes; corrected error in VIN range)
1	4/23/2010	Initial publication

- The rear center seat rattles at the backrest latching mechanism.
- The rear center seat release handle for folding the center seat backrest flat does not function.

Technical Background

The rod between the rear center backrest latch and the release lever is detached (Figure 1). After the rod detaches and the center backrest is latched to the rear backrest on the driver's side, the center backrest cannot be folded flat independent from the driver's side rear backrest.

The loose connection inside the latching mechanism can create noises from the rear center seat when the vehicle is driven over rough roads.



Figure 1. The rear center backrest latch and release lever.

Production Solution

The connection between the release rod and the release lever is optimized. The release lever is optimized.

Service

Follow the instructions below to replace both the release lever and the lock cover.

1. Manually unlatch the center backrest from the driver's side rear backrest. To do this, insert a small, flat, regular screwdriver (with an end width of 6 mm-8 mm) into the latch to release the locking mechanism (Figure 2).

The latch concept is the same as a door latch; pressing inward will release the latch.

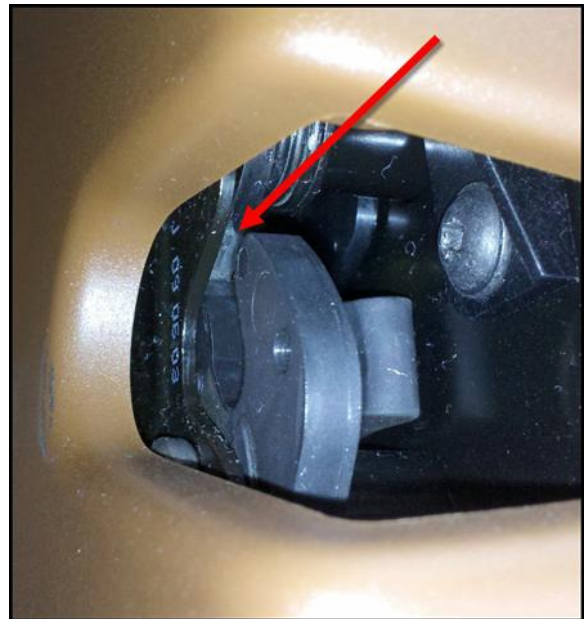

Figure 2. Arrow indicates direction to insert screwdriver. The latch is shown in the locked position.

2. Use the repair instructions in Elsa to remove and replace the release lever button and the lock cover (Figure 3 and Figure 4).

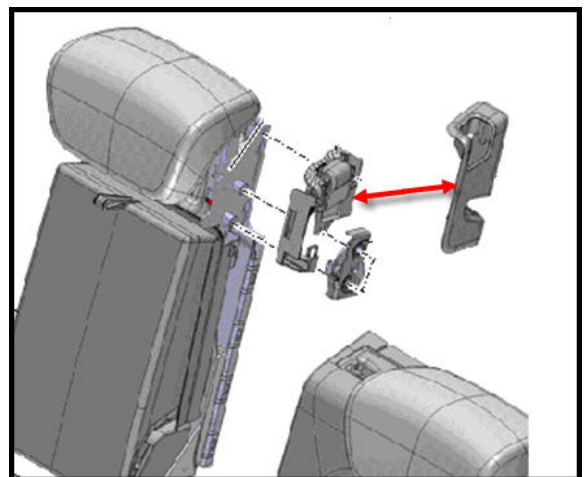

Figure 3. The release lever button and lock cover (arrows).

Technical Service Bulletin



Figure 4. The optimized connection point of the release lever and the connecting rod.

Warranty

Claim Type:	Use applicable claim type. If vehicle is outside any warranty, this Technical Service Bulletin is informational only.		
Service Number:	7263		
Damage Code:	0017		
Labor Operations:	Replace lock cover and release lever	7263 9999	30 TU
Diagnostic Time:	GFF	No allowance	0 TU
	Road test prior to service procedure	0121 0002	10 TU
	Road test after service procedure	0121 0004	10 TU
	Technical diagnosis at dealer's discretion (Refer to Section 2.2.1.2 and Audi Warranty Online for DADP allowance details)		
Claim Comment:	As per TSB #2023324/3		

All warranty claims submitted for payment must be in accordance with the *Audi Warranty Policies and Procedures Manual*. Claims are subject to review or audit by Audi Warranty.



Required Parts and Tools

Part Number	Part Description	Quantity
See ETKA	Grip for Release Lever	1
See ETKA	Lock Cover	1

Additional Information

All parts and service references provided in this TSB (2023324) are subject to change and/or removal. Always check with your Parts Department and service manuals for the latest information.