



Service Bulletin

INFORMATION

Subject: Pre-Formed and Pre-Flared Hydraulic Brake Pipe Kits Now Available for Service

Models: 2000-2006 Cadillac Escalade Models
2000-2006 Chevrolet Avalanche, Suburban, Tahoe
1999-2007 Chevrolet Silverado
2000-2006 GMC Yukon Models
1999-2007 GMC Sierra

The purpose of this bulletin is to inform dealers of an improved service strategy to aid in the replacement of hydraulic brake pipes for the above listed vehicles. Customer Care and Aftersales (CCA) has released pre-formed and pre-flared hydraulic brake pipe kits.

These kits can be used anytime replacement of the entire brake pipe assemblies is required. These kits include all the pre-formed and pre-flared brake pipes needed when replacing the entire brake pipe assembly, except the rear axle crossover pipe. If the rear axle crossover pipe requires replacement, refer to the appropriate parts catalog for ordering and the Brake Pipe Replacement procedure in SI for installation instructions. The following procedure describes how to install these kits.

Replacement Procedure (Pickup and Cab Chassis)

Removal

Warning: Brake fluid may irritate eyes and skin. In case of contact, take the following actions:

- **Eye contact—rinse thoroughly with water.**
- **Skin contact—wash with soap and water.**
- **If ingested—consult a physician immediately.**

Caution: Avoid spilling brake fluid onto painted surfaces, electrical connections, wiring, or cables. Brake fluid will damage painted surfaces and cause corrosion to electrical components. If any brake fluid comes in contact with painted surfaces, immediately flush the area with water. If any brake fluid comes in contact with electrical connections, wiring, or cables, use a clean shop cloth to wipe away the fluid.

Caution: Care should be taken to ensure that dirt, water, grease, or other contaminants do not enter the new brake pipes and threaded end fittings when the pipes are being installed into the vehicle. Use tape or other appropriate methods to cover the threaded end fittings and the ends of the pipes to prevent dirt, water, grease, or other contaminants from entering the pipes. Remove all protective measures before connecting the end fittings to the master cylinder, brake pressure proportioning valve (where equipped), brake pressure modulator valve (BPMV), or flexible brake hoses.

Caution: Cleanliness is important for the proper function of the hydraulic brake system. Clean all dirt, water, rust, etc from the areas adjacent to each brake pipe tube nut before removing the brake pipe tube nuts. Take care to ensure that no contaminants enter any hydraulic fittings or openings during removal or installation of the brake pipes.

Caution: Before removing any brake pipes from the master cylinder, ABS module (BPMV), and the brake pressure proportioning valve (where equipped) identify the port locations. On the BPMV identify the port location for each hydraulic component (e.g., Master Cylinder Primary, Master Cylinder Secondary, LF corner, RF corner, LR corner, RR corner, Rear Brake). On the brake pressure proportioning valve identify the port locations for each hydraulic component (e.g. master cylinder primary inlet, master cylinder primary outlet, master cylinder secondary inlet, master cylinder secondary outlet, pre-charge pump). When installing the replacement pipes, ensure that the replacement pipes are installed in the correct port locations on the master cylinder, BPMV, and brake pressure proportioning valve, where equipped. If the pipes are not installed in the correct port locations on all the hydraulic components, the brake system including the ABS system and/or TCS/VSES Stabilitrak system (where equipped) will not operate correctly and may result in damage to the hydraulic brake components.

Note: This procedure does not comprehend specific vehicle models or brake system configurations. The illustrations may not exactly reflect the vehicle being repaired. Some LD pickups and LD SUVs may be equipped with a brake pressure combination valve and a brake pressure modulator valve pre-charge pump.

The brake pipes attached to these components should be removed and replaced with the replacement pipes provided in the service kit.

Note: This procedure is not intended for the repair or replacement of a single damaged brake pipe. This procedure is for the replacement of the entire brake pipe assemblies with pre-formed and pre-flared components.

Note: Remove the brake pipes from the existing routing clips carefully to avoid damaging the clips as all the clips will be re-used. The new brake pipes will be reinstalled into the existing clips. After installing the new brake pipes, inspect the routing of the brake pipes to ensure that the new brake pipes do not contact or rub on any frame, body, or chassis components. Carefully bend the pipes to increase clearance as required.

Note: The brake pipes in these kits are not an exact duplicate of the pipes currently installed on the vehicle. These pipes have a nylon coating to provide better corrosion protection and may have slightly different shapes and bends and may not exactly match the brake pipes being replaced. Some original equipment pipes may use flexible hose sections near the master cylinder or brake pressure proportioning valve that attaches to the master cylinder to brake booster mounting studs. The replacement pipes in this kit will not use the flexible hose sections. The replacement pipes have been designed to fit each vehicle application. Because of the nylon coating on the outside of the brake pipes, the outside diameter of the pipe is slightly larger than the original pipes. Extra effort may be required to insert the pipes into the existing mounting clips. It is recommended to finger start all the threaded end fittings into the master cylinder, brake pressure proportioning valve, brake pressure modulation valve, and flexible brake hoses before performing the final tightening and torque of each fitting.

Note: The brake pipes in these kits may have additional large radius shipping bends to allow the pipes to fit within the cardboard box. Those pipes with additional shipping bends will have tags on either side of each shipping bend. Carefully straighten the section of pipe between the tags to remove the shipping bend. Take care not to kink or damage the brake pipes. If a brake pipe becomes kinked or damaged while removing the shipping bends, it must be repaired or replaced before installation into the vehicle. Take care not to cut, nick, abrade or otherwise damage the nylon coating on the brake pipes during installation.

Note: For Chassis Cab models, due to the installation and mounting of the aftermarket equipment/body on the rear of the chassis (i.e. flatbed, stake bed, box van, dump body, etc) by the second stage manufacturer or vehicle upfitter, it may be difficult or prohibitive to remove the aftermarket body to enable replacement of the OEM rear brake pipe. Each vehicle will need to be assessed individually, however, it may be preferable to hand bend a service replacement brake pipe using GM P/N 88936298 PIPE, BRK (STEEL) (1/4" X 16 FT ROLL) nylon coated bulk tubing available separately from GM dealers, using GM P/N 15103241 Fitting, BRK PIPE (1/2-20-2A THD) (1/4 TUBE STL) to attach to the ABS module (BPMV) and GM P/N 11609443 Tube Nut (7/16-24 UNS-2A THD) to attach to the rear axle jounce hose. These tube nuts are designed to properly fit over the nylon coated brake tubing. The tube nuts can also be removed from the replacement rear pipe included in the brake pipe service kit and installed on the hand bent service replacement pipe. Route the hand bent service replacement pipe from the ABS module (BPMV) to the rear axle jounce hose ensuring adequate clearance is maintained between the pipe and surrounding components to ensure that the pipe is not damaged in service. Attach the hand bent service replacement brake pipe securely to the chassis using brake pipe clips, rubber coated P-clips, or other suitable methods. The maximum distance between attachment points or clips should not exceed 457 mm (18"). If a brake pipe has a directional change (bend) of 30 degrees or more, a clip needs to be located as close as possible to the bend.

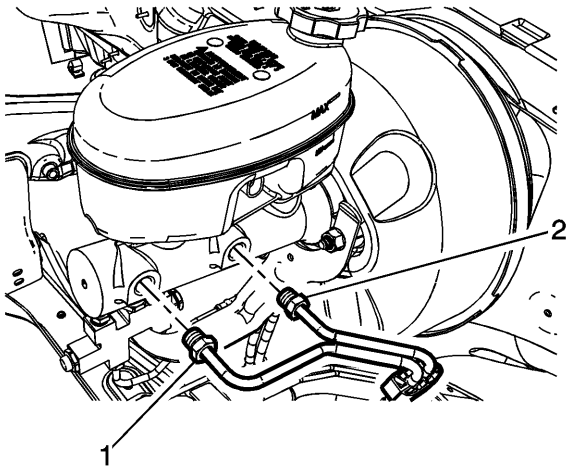

1. Disconnect the master cylinder secondary (1) and primary (2) brake pipe fittings from the master cylinder.
2. Plug the master cylinder outlet ports to prevent brake fluid loss and contamination.

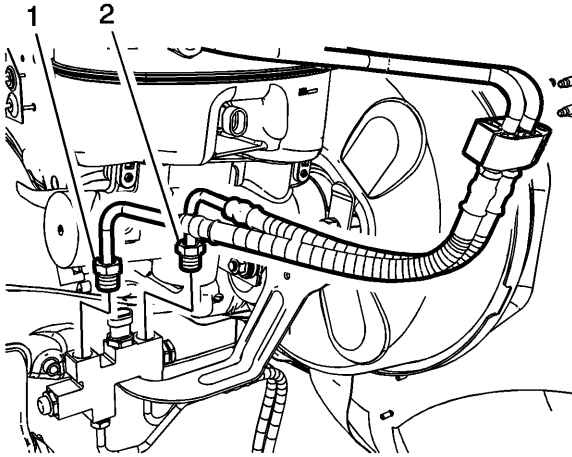

3. For vehicles equipped with a combination valve, disconnect the master cylinder secondary (1) and primary (2) brake pipe fittings from the combination valve.
4. Plug the combination valve inlet ports to prevent brake fluid loss and contamination.

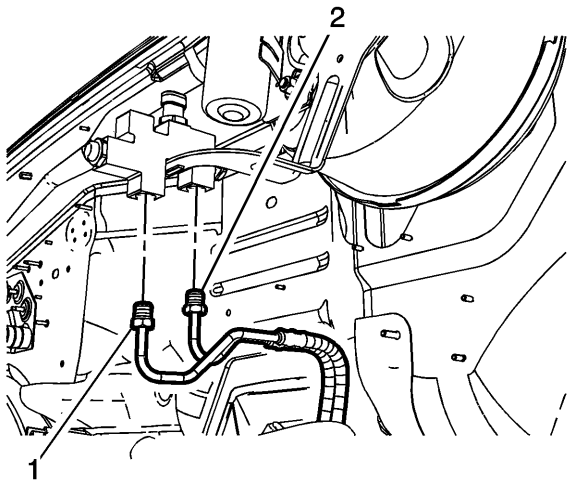

5. For vehicles equipped with a combination valve, disconnect the secondary (1) and primary (2) brake pipe fittings from the combination valve.
6. Raise and support the vehicle. Refer to Lifting and Jacking the Vehicle in SI.
7. Remove the front and rear tire and wheel assemblies. Refer to Tire and Wheel Removal and Installation in SI.
8. Apply ACDelco Rust Penetrant and Inhibitor 10-4020 (GM P/N 88862628) or equivalent penetrating lubricant to the bleeder screws of the following components:
 - Front brake calipers
 - Rear brake calipers
9. Apply ACDelco Rust Penetrant and Inhibitor 10-4020 (GM P/N 88862628) or equivalent penetrating lubricant to the brake pipe fitting tube nuts at the following locations:
 - Front brake hoses
 - Brake pressure modulator valve (BPMV)
 - Rear brake hose(s)
10. Remove the left and right front wheelhouse panels. Refer to Wheelhouse Panel Replacement in SI.
11. Remove the engine protection shield, if equipped. Refer to Engine Protection Shield Replacement in SI.

12. Reference mark the parking brake front cable adjuster nut at the equalizer and disconnect the parking brake front cable. Refer to Parking Brake Front Cable Replacement in SI.
13. Disconnect any wiring ground harnesses from the body to the frame. Refer to Power and Grounding Component Views in SI
14. Remove the 3 left side body mount bolts and the core support mount bolt. Refer to Drivetrain and Front Suspension Frame Insulator Replacement in SI.
Note: Only raise the body enough to gain hand access to the brake pipe routing clips. Pay careful attention to avoid stressing hoses and wiring harnesses.
15. Carefully raise the left side of the body from inboard of the frame rails approximately 51 mm (2 in).
Note: Place the support blocks inboard of the frame rails and as close to the body mounting points as possible to evenly distribute the weight of the vehicle body.
16. Place blocks or supports inboard of the frame side rails to support the body in at least 3 locations.
17. Remove the left side pickup box bolts and loosen, but do not remove, the right side pickup box bolts. Refer to Pickup Box Replacement in SI.
Note: Only raise the pickup box enough to gain hand access to the brake pipe routing clips. Pay careful attention to avoid stressing hoses and wiring harnesses.
18. Carefully raise the left side of the pickup box approximately 51 mm (2 in).
Note: Place the support blocks as close to the pickup box mounting points as possible to evenly distribute the weight of the vehicle body.
19. Place blocks or supports inboard of the frame side rails to support the pickup box in at least 3 locations.
20. Release the body wiring harness conduit from the brake pipe retainers on the left side of the vehicle.
21. Position and secure the wiring harness aside.

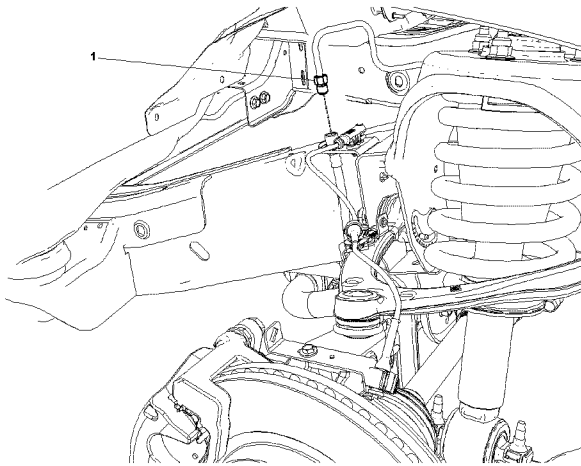

22. Using side cutters, cut the right front brake pipe as close as possible to the brake pipe fitting (1) at the brake hose.
23. Using a 6 point socket, remove and discard the right front brake pipe fitting tube nut.
24. Disconnect the left front wheel speed sensor electrical connector and remove the sensor harness retaining clips from the top of the left frame rail.

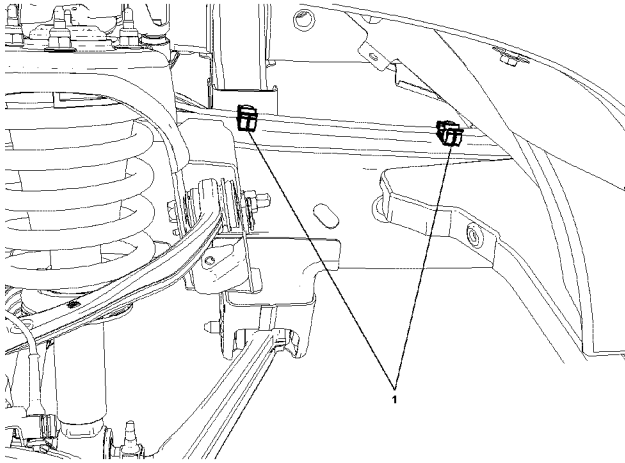

25. Release the right front brake pipe from the clips (1) on the right frame rail.

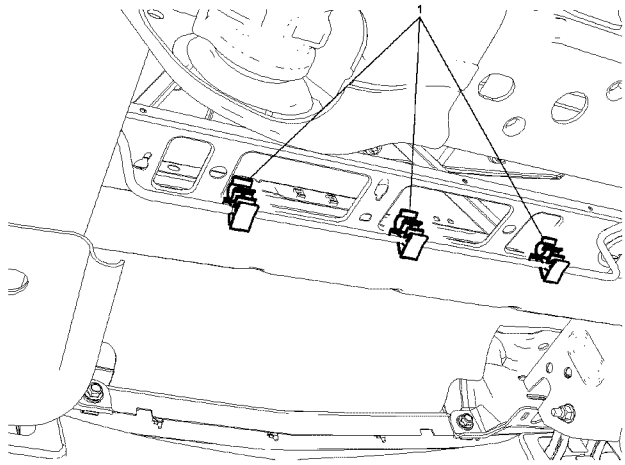

26. Release the right front brake pipe from the front frame crossmember clips (1).

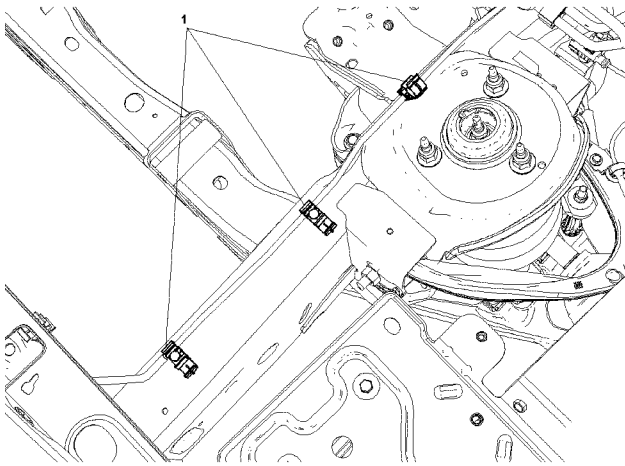

27. Release the right front brake pipe from the left front frame rail clips (1).

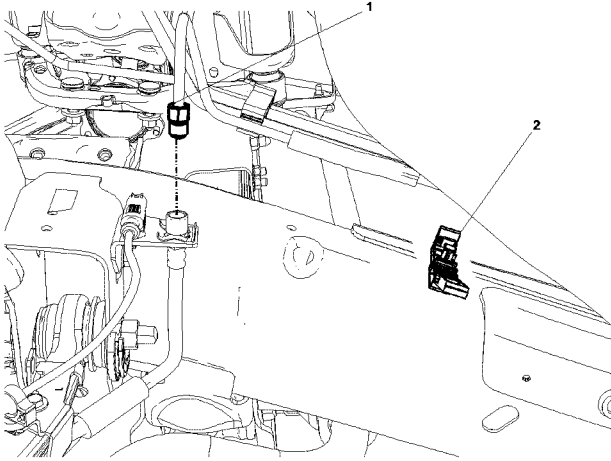

28. Using side cutters, cut the left front brake pipe as close as possible to the brake pipe fitting (1) at the brake hose.
29. Using a 6 point socket, remove and discard the left front brake pipe fitting tube nut.
30. Release the front brake pipes assembly from the left frame rail clip (2).

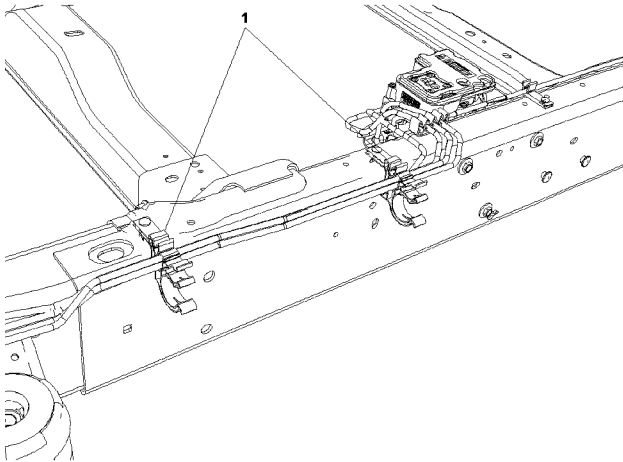

31. Release the front brake pipes assembly from the left frame rail clips (1).
32. Clean the area surrounding the brake pipe fittings on the BPMV thoroughly to remove all dirt and debris.

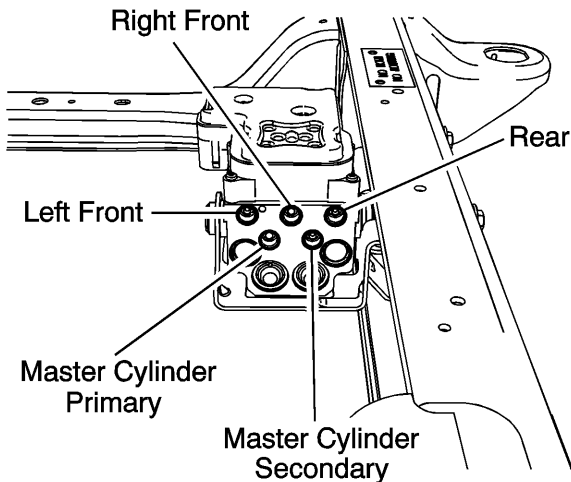

Note: Due to the similarity of the brake pipe fitting tube nuts, it is imperative to identify the individual brake pipe locations on the BPMV to ensure correct assembly.

33. Identify the brake pipe port locations at the BPMV prior to disconnecting the brake pipe fittings.

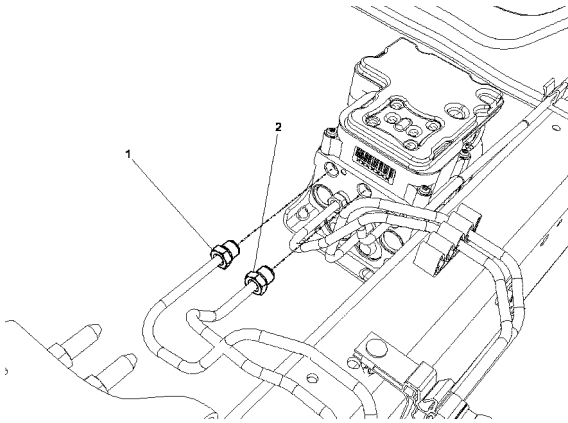

34. Using side cutters, cut the left front (1) and right front (2) brake pipes as close as possible to the brake pipe fittings at the BPMV.
35. Using a 6 point socket, remove and discard the front brake pipe fitting tube nuts.

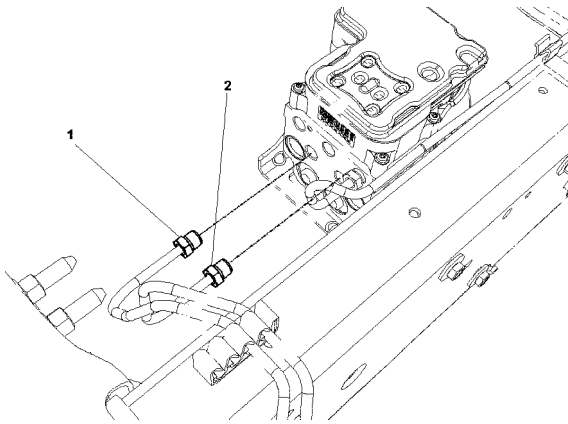

36. Using side cutters, cut the master cylinder primary (1) and secondary (2) brake pipes as close as possible to the brake pipe fitting at the BPMV.
37. Using a 6 point socket, remove and discard the brake pipe fitting tube nuts.
38. Carefully remove the brake pipe routing clips from the front brake pipe assembly.
39. Maneuver the front brake pipes one at a time and remove the brake pipes from the vehicle.

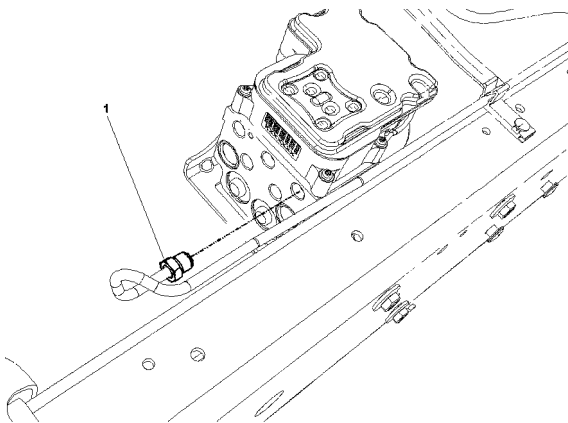

40. Using side cutters, cut the rear brake pipe (1) as close as possible to the brake pipe fitting at the BPMV.

41. Using a 6 point socket, remove and discard the brake pipe fitting tube nut.

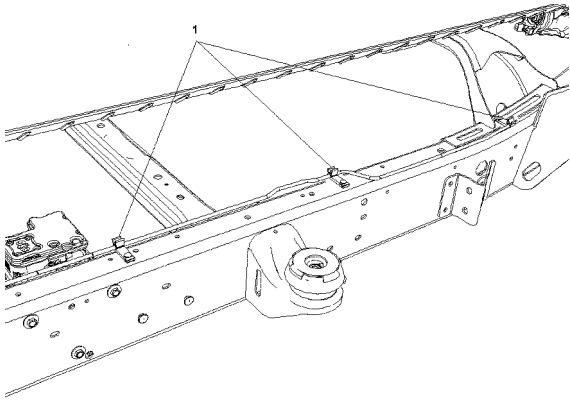

42. Release the rear brake pipe from the left frame rail clips (1).

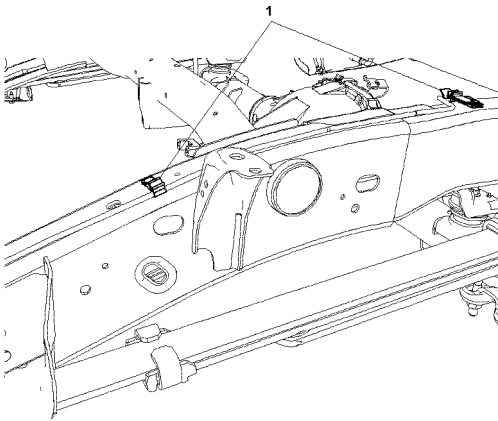

43. Release the rear brake pipe from the left frame rail clips (1).

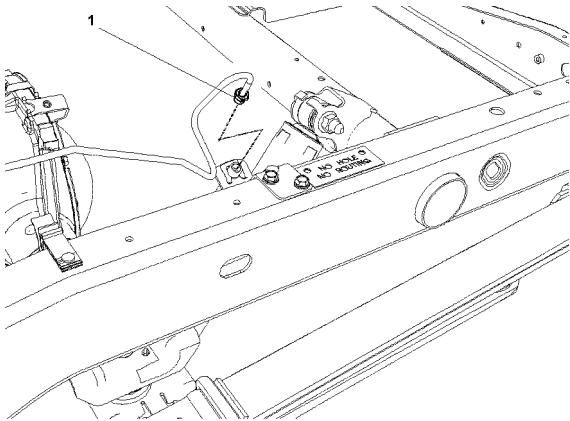

44. Using side cutters, cut the rear brake pipe (1) as close as possible to the brake pipe fitting at the rear brake hose.
45. Using a 6 point socket, remove and discard the rear brake pipe fitting tube nut.
46. Remove the rear brake pipe from the vehicle.

Installation

Caution: Use the correct fastener in the correct location. Replacement fasteners must be the correct part number for that application. Do not use paints, lubricants, or corrosion inhibitors on fasteners, or fastener joint surfaces, unless specified. These coatings affect fastener torque and joint clamping force and may damage the fastener. Use the correct tightening sequence and specifications when installing fasteners in order to avoid damage to parts and systems. When using fasteners that are threaded directly into plastic, use extreme care not to strip the mating plastic part(s). Use hand tools only, and do not use any

kind of impact or power tools. Fastener should be hand tightened, fully seated, and not stripped.

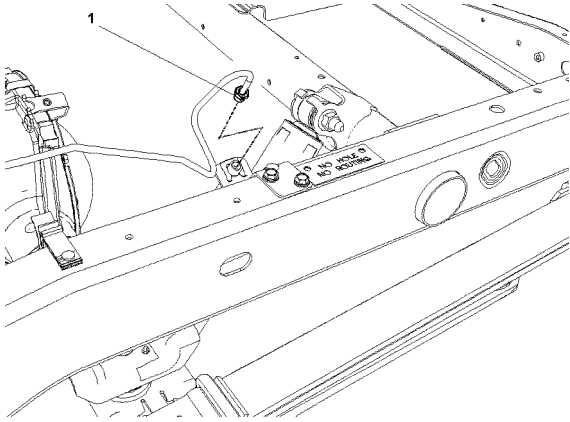

1. Install the rear brake pipe.
 2. Install the rear brake pipe fitting tube nut (1).
- Tighten:** Tighten the nut to 25 Y (18 lb ft)

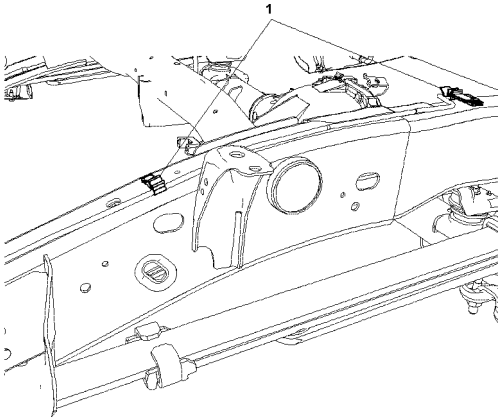

3. Install the rear brake pipe to the left frame rail clips (1).

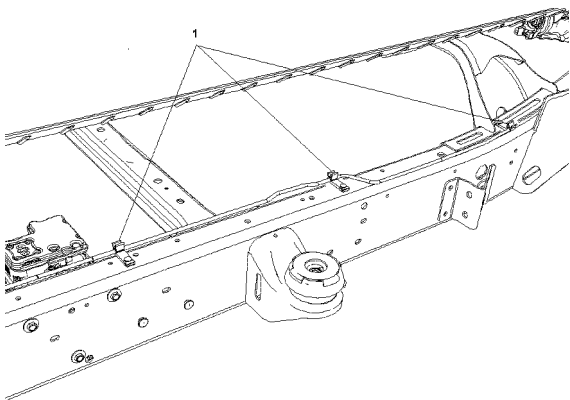

4. Install the rear brake pipe to the left frame rail clips (1).

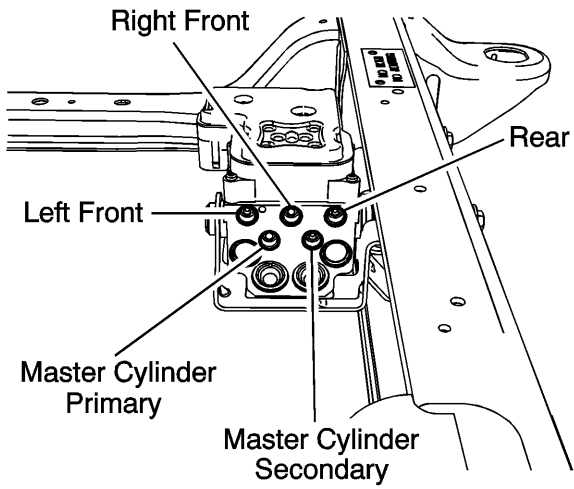

Note: Due to the similarity of the brake pipe fitting tube nuts, it is imperative to identify the individual brake pipe locations on the BPMV to ensure correct assembly.

5. Connect the brake pipe fittings to the BPMV port locations identified during removal.

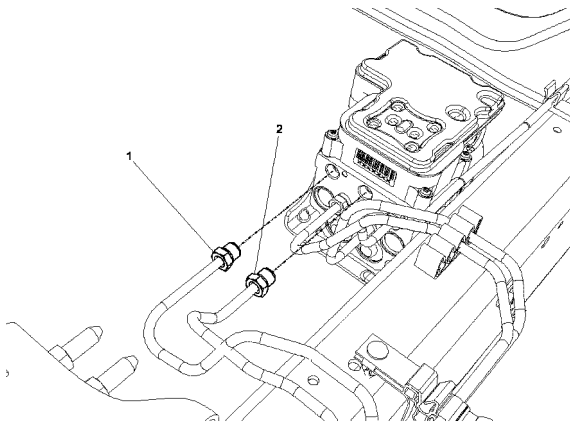

6. Install the right front brake pipe fitting tube nut (2).
Tighten: Tighten the nut to 25 Y (18 lb ft)
7. Install the left front brake pipe fitting tube nut (1).
Tighten: Tighten the nut to 25 Y (18 lb ft)

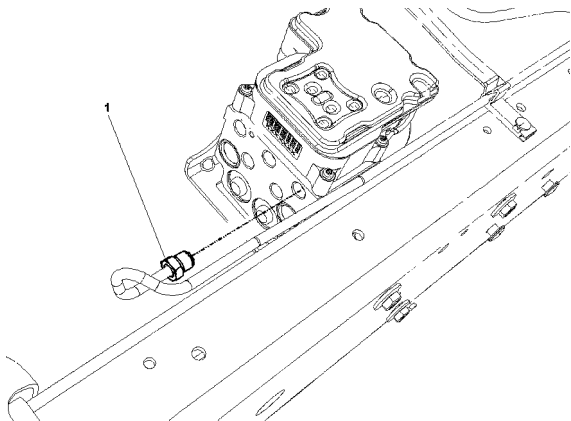

8. Install the rear brake pipe fitting tube nut (1).

Tighten: Tighten the nut to 25 Y (18 lb ft)

Note: Install the brake pipes to the routing clips and retaining clips after all the brake pipes are fitted to the vehicle.

9. Install the master cylinder primary and secondary brake pipe assembly to the vehicle.

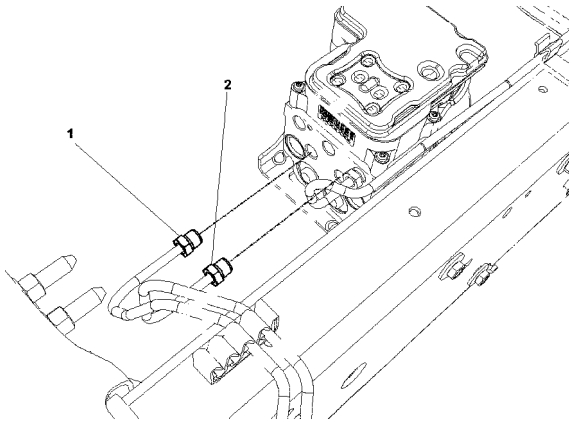

10. Install the master cylinder primary brake pipe fitting tube nut (1).

Tighten: Tighten the nut to 25 Y (18 lb ft)

11. Install the master cylinder secondary brake pipe fitting tube nut (2).

Tighten: Tighten the nut to 25 Y (18 lb ft)

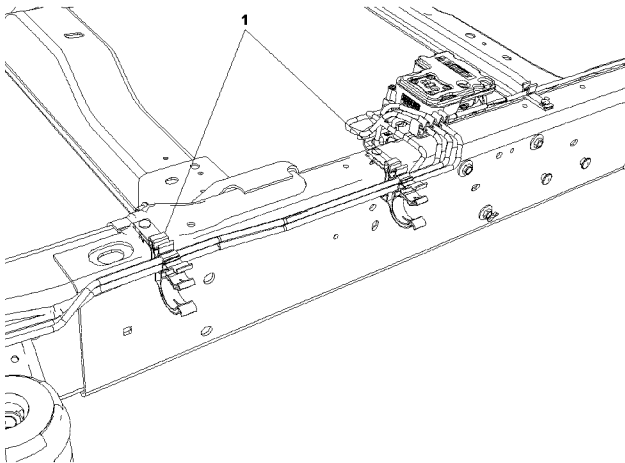

12. Install the front brake pipes assembly to the left frame rail clips (1).

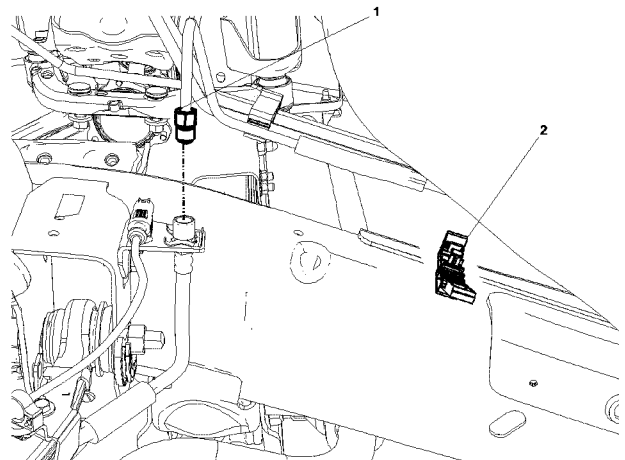

13. Install the left front brake pipe fitting tube nut (1).

Tighten: Tighten the nut to 25 Y (18 lb ft)

14. Install the front brake pipes assembly to the left frame rail clip (2).

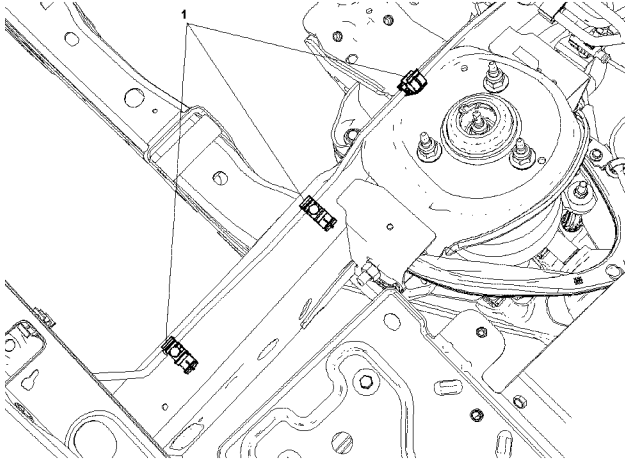

15. Install the right front brake pipe to the left front frame rail clips (1).

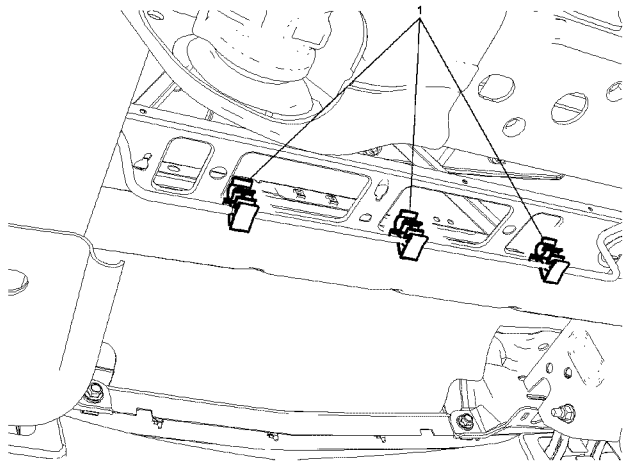

16. Install the right front brake pipe to the front frame crossmember clips (1).

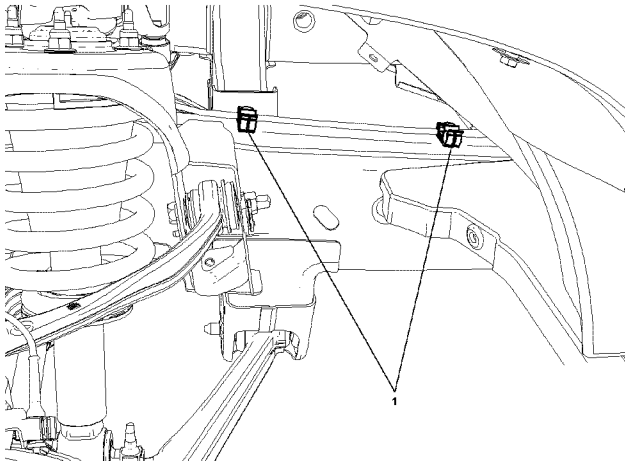

17. Install the right front brake pipe to the clips (1) on the right frame rail.

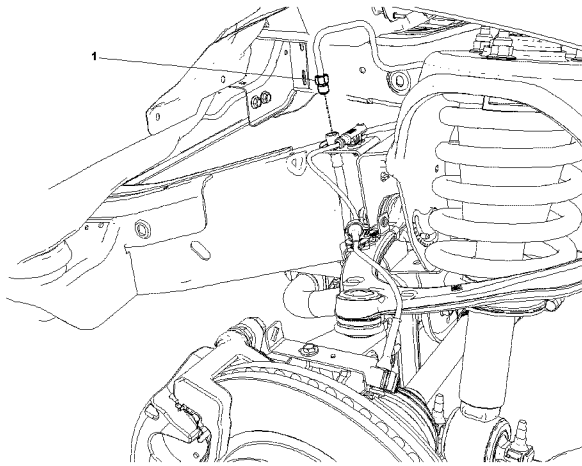

18. Install the right front brake pipe fitting tube nut (1).

Tighten: Tighten the nut to 25 Y (18 lb ft)

19. Reposition the body wiring harness into the brake pipe retaining clips.
20. Remove the blocks, lower the body and install the 3 left side body mount bolts. Refer to Drivetrain and Front Suspension Frame Insulator Replacement in SI.
21. Remove the blocks, lower the pickup box and install the pickup box bolts. Refer to Pickup Box Replacement in SI.
22. Inspect the pickup box for correct alignment.
23. Connect any wiring ground harnesses from the body to the frame. Refer to Power and Grounding Component Views in SI.
24. Connect the parking brake front cable. Refer to Parking Brake Front Cable Replacement in SI.
25. Connect the left front wheel speed sensor electrical connector and install the sensor harness retaining clips to the top of the left frame rail.
26. Install the engine protection shield, if equipped. Refer to Engine Protection Shield Replacement in SI.
27. Install the left and right front wheelhouse panels. Refer to Wheelhouse Panel Replacement in SI.
28. Lower the vehicle enough to access the combination valve and master cylinder brake pipe fittings.

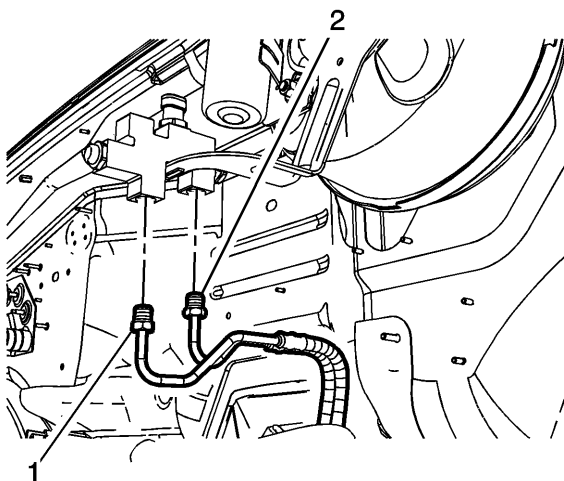

29. For vehicles equipped with a combination valve, connect the secondary (1) and primary (2) brake pipe fittings to the combination valve.

Tighten: Tighten the brake pipe fittings to 25 Y (18 lb ft).

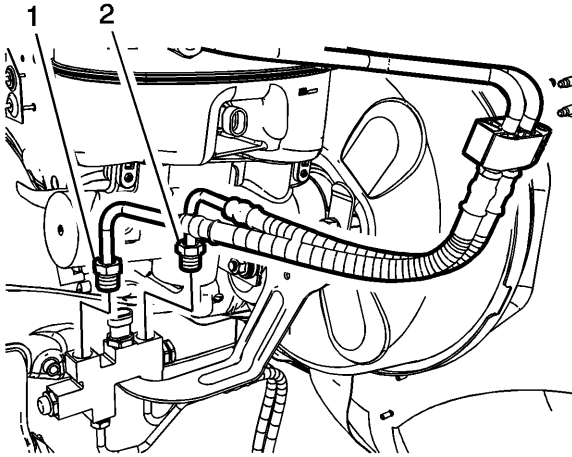

30. For vehicles equipped with a combination valve, connect the master cylinder secondary (1) and primary (2) brake pipe fittings to the combination valve.

Tighten: Tighten the brake pipe fittings to 25 Y (18 lb ft).

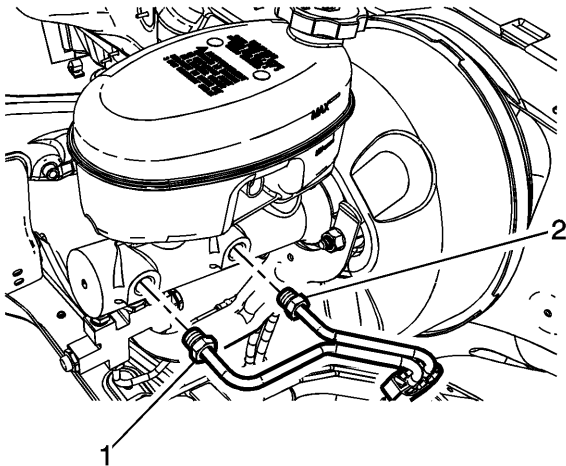

31. Connect the master cylinder secondary (1) and primary (2) brake pipe fittings to the master cylinder.

Tighten: Tighten the nut to 25 Y (18 lb ft)

32. Bleed the hydraulic brake system. Refer to Hydraulic Brake System Bleeding in SI.

33. Install the front and rear tire and wheel assemblies. Refer to Tire and Wheel Removal and Installation in SI.

Replacement Procedure (Utilities)

Removal

Warning: Brake fluid may irritate eyes and skin. In case of contact, take the following actions:

- **Eye contact—rinse thoroughly with water.**
- **Skin contact—wash with soap and water.**
- **If ingested—consult a physician immediately.**

Caution: Avoid spilling brake fluid onto painted surfaces, electrical connections, wiring, or cables. Brake fluid will damage painted surfaces and cause corrosion to electrical components. If any brake fluid comes in contact with painted surfaces, immediately flush the area with water. If any brake fluid comes in contact with electrical connections, wiring, or cables, use a clean shop cloth to wipe away the fluid.

Caution: Care should be taken to ensure that dirt, water, grease, or other contaminants do not enter the new brake pipes and threaded end fittings when the pipes are being installed into the vehicle. Use tape or other appropriate methods to cover the threaded end fittings and the ends of the pipes to prevent dirt,

water, grease, or other contaminants from entering the pipes. Remove all protective measures before connecting the end fittings to the master cylinder, brake pressure proportioning valve (where equipped), brake pressure modulator valve (BPMV), or flexible brake hoses.

Caution: Cleanliness is important for the proper function of the hydraulic brake system. Clean all dirt, water, rust, etc from the areas adjacent to each brake pipe tube nut before removing the brake pipe tube nuts. Take care to ensure that no contaminants enter any hydraulic fittings or openings during removal or installation of the brake pipes.

Caution: Before removing any brake pipes from the master cylinder, ABS module (BPMV), and the brake pressure proportioning valve (where equipped) identify the port locations. On the BPMV identify the port location for each hydraulic component (e.g., Master Cylinder Primary, Master Cylinder Secondary, LF corner, RF corner, LR corner, RR corner, Rear Brake). On the brake pressure proportioning valve identify the port locations for each hydraulic component (e.g. master cylinder primary inlet, master cylinder primary outlet, master cylinder secondary inlet, master cylinder secondary outlet, pre-charge pump). When installing the replacement pipes, ensure that the replacement pipes are installed in the correct port locations on the master cylinder, BPMV, and brake pressure proportioning valve, where equipped. If the pipes are not installed in the correct port locations on all the hydraulic components, the brake system including the ABS system and/or TCS/VSES Stabiltrak system (where equipped) will not operate correctly and may result in damage to the hydraulic brake components.

Note: This procedure does not comprehend specific vehicle models or brake system configurations. The illustrations may not exactly reflect the vehicle being repaired. Some LD pickups and LD SUVs may be equipped with a brake pressure combination valve and a brake pressure modulator valve pre-charge pump. The brake pipes attached to these components should be removed and replaced with the replacement pipes provided in the service kit.

Note: This procedure is not intended for the repair or replacement of a single damaged brake pipe. This procedure is for the replacement of the entire brake pipe assemblies with pre-formed and pre-flared components.

Note: Remove the brake pipes from the existing routing clips carefully to avoid damaging the clips as all the clips will be re-used. The new brake pipes will be reinstalled into the existing clips. After installing the new brake pipes, inspect the routing of the brake pipes to ensure that the new brake pipes do not contact or rub on any frame, body, or chassis components. Carefully bend the pipes to increase clearance as required.

Note: The brake pipes in these kits are not an exact duplicate of the pipes currently installed on the vehicle. These pipes have a nylon coating to provide better corrosion protection and may have slightly different shapes and bends and may not exactly match the brake pipes being replaced. Some original equipment pipes may use flexible hose sections near the master cylinder or brake pressure proportioning valve that attaches to the master cylinder to brake booster mounting studs. The replacement pipes in this kit will not use the flexible hose sections. The replacement pipes have been designed to fit each vehicle application. Because of the nylon coating on the outside of the brake pipes, the outside diameter of the pipe is slightly larger than the original pipes, Extra effort may be required to insert the pipes into the existing mounting clips. It is recommended to finger start all the threaded end fittings into the master cylinder, brake pressure proportioning valve, brake pressure modulation valve, and flexible brake hoses before performing the final tightening and torque of each fitting.

Note: The brake pipes in these kits may have additional large radius shipping bends to allow the pipes to fit within the cardboard box. Those pipes with additional shipping bends will have tags on either side of each shipping bend. Carefully straighten the section of pipe between the tags to remove the shipping bend. Take care not to kink or damage the brake pipes. If a brake pipe becomes kinked or damaged while removing the shipping bends, it must be repaired or replaced before installation into the vehicle. Take care not to cut, nick, abrade or otherwise damage the nylon coating on the brake pipes during installation.

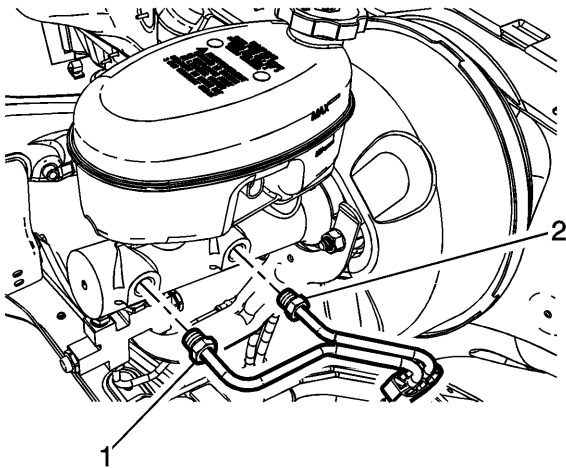

1. Disconnect the master cylinder secondary (1) and primary (2) brake pipe fittings from the master cylinder.
2. Plug the master cylinder outlet ports to prevent brake fluid loss and contamination.

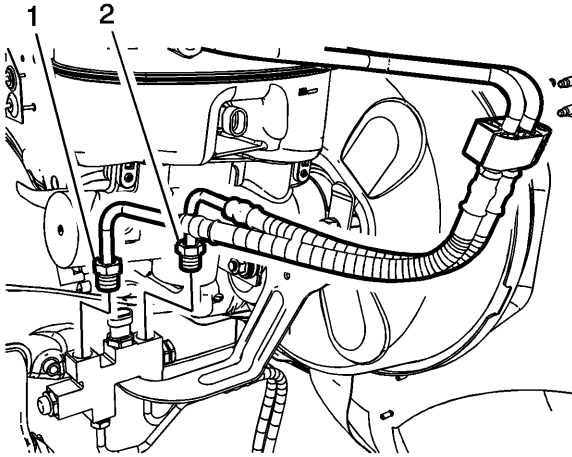

3. Disconnect the master cylinder secondary (1) and primary (2) brake pipe fittings from the combination valve.
4. Plug the combination valve inlet ports to prevent brake fluid loss and contamination.

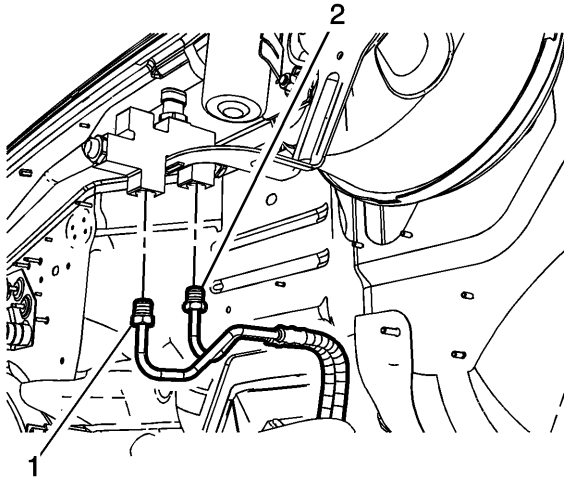

5. Disconnect the secondary (1) and primary (2) brake pipe fittings from the combination valve.
6. Plug the combination valve outlet ports to prevent brake fluid loss and contamination.

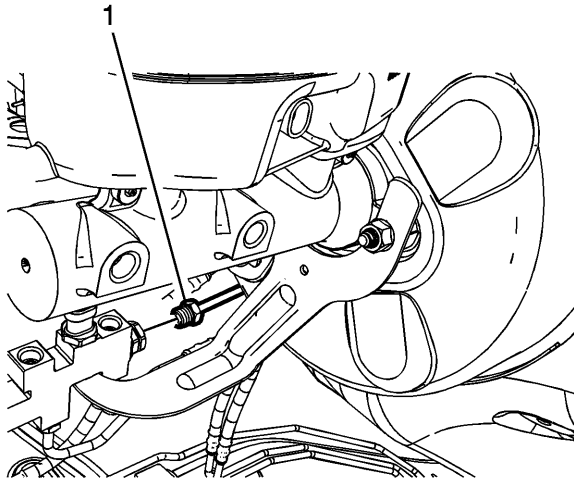

7. If equipped, disconnect the BPMV front brake pipe fitting (1) from the combination valve.
8. Plug the combination valve port to prevent brake fluid loss and contamination.

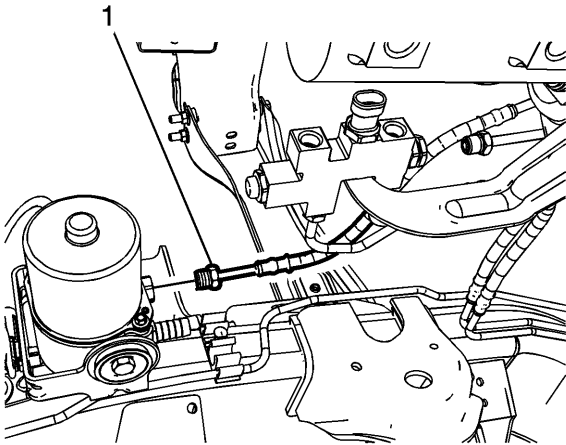

9. If equipped, disconnect the BPMV front brake pipe fitting (1) from the brake pressure modulator valve (BPMV) pre-charge pump.
10. Plug the BPMV pre-charge pump port to prevent brake fluid loss and contamination.
11. Lower the spare tire and wheel assembly.
12. Raise and support the vehicle. Refer to Lifting and Jacking the Vehicle in SI.
13. Remove the front and rear tire and wheel assemblies. Refer to Tire and Wheel Removal and Installation in SI.
14. Apply ACDelco Rust Penetrant and Inhibitor 10-4020 (GM P/N 88862628) or equivalent penetrating lubricant to the bleeder screws of the following components:
 - Front brake calipers
 - Rear brake calipers
15. Apply ACDelco Rust Penetrant and Inhibitor 10-4020 (GM P/N 88862628) or equivalent penetrating lubricant to the brake pipe fitting tube nuts at the following locations:
 - Front brake hoses
 - Brake pressure modulator valve (BPMV)
 - Rear brake hose(s)
16. Remove the left and right front wheelhouse panels. Refer to Wheelhouse Panel Replacement in SI.

17. Remove the engine shield, if equipped. Refer to Engine Shield Replacement in SI.
18. Reference mark the parking brake front cable adjuster nut at the equalizer and disconnect the parking brake front cable. Refer to Parking Brake Front Cable Replacement in SI.
19. Disconnect any wiring ground harnesses from the body to the frame. Refer to Power and Grounding Component Views in SI.
20. Remove the 6 left side body mount bolts and the core support mount bolt. Refer to Drivetrain and Front Suspension Frame Insulator Replacement in SI.

Note: Only raise the body enough to gain hand access to the brake pipe routing clips. Pay careful attention to avoid stressing hoses and wiring harnesses.
21. Carefully raise the left side of the body from inboard of the frame rails approximately 51 mm (2 in).

Note: Place the support blocks inboard of the frame rails and as close to the body mounting points as possible to evenly distribute the weight of the vehicle body.
22. Place blocks or supports inboard of the frame side rails to support the body in at least 3 locations.
23. Release the body wiring harness conduit from the brake pipe retainers on the left side of the vehicle.
24. Position and secure the wiring harness aside.

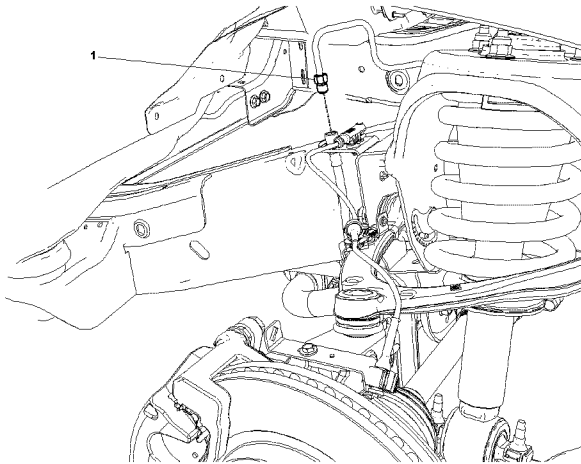

25. Using side cutters, cut the right front brake pipe as close as possible to the brake pipe fitting (1) at the brake hose.
26. Using a 6 point socket, remove and discard the right front brake pipe fitting tube nut.
27. Disconnect the left front wheel speed sensor electrical connector and remove the sensor harness retaining clips from the top of the left frame rail.

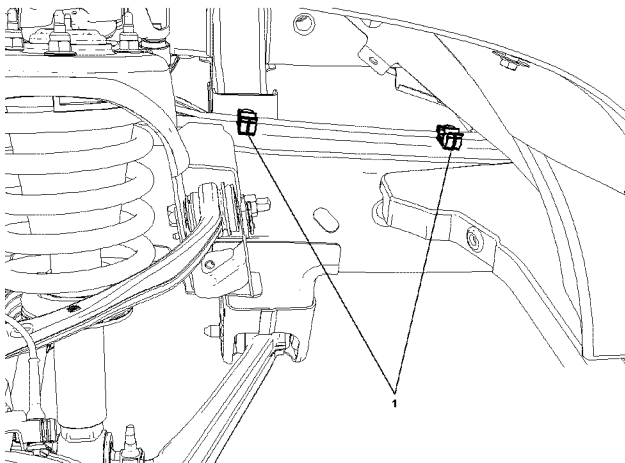

28. Release the right front brake pipe from the clips (1) on the right frame rail.

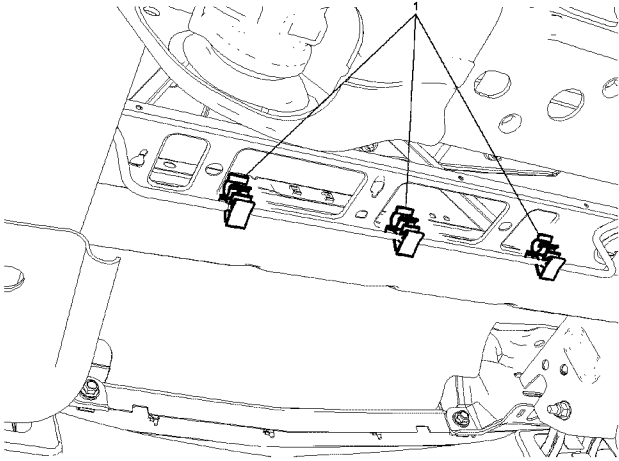

29. Release the right front brake pipe from the front frame crossmember clips (1).

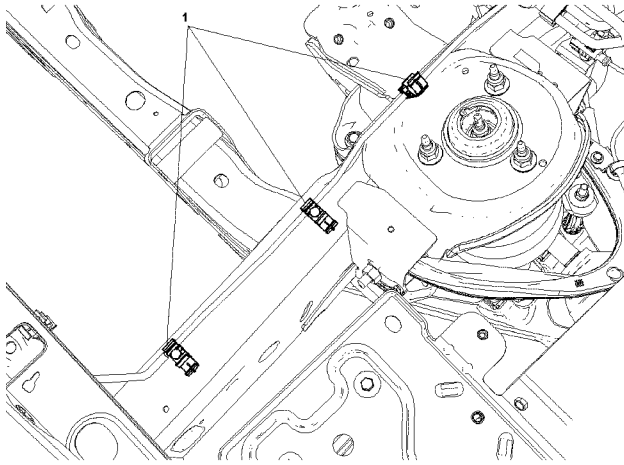

30. Release the right front brake pipe from the left front frame rail clips (1).

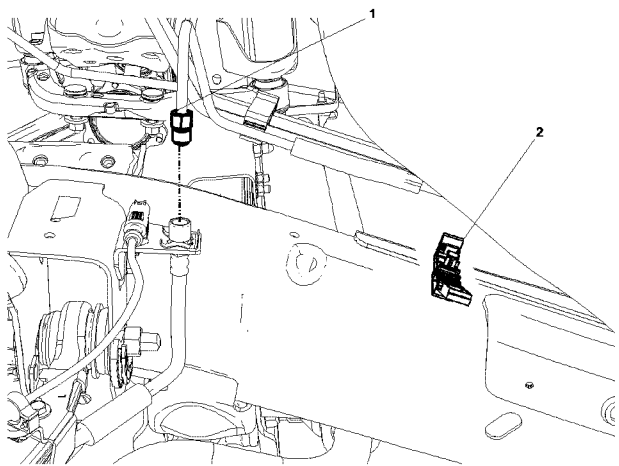

31. Using side cutters, cut the left front brake pipe as close as possible to the brake pipe fitting (1) at the brake hose.

32. Using a 6 point socket, remove and discard the left front brake pipe fitting tube nut.

33. Release the front brake pipes assembly from the left frame rail clip (2).

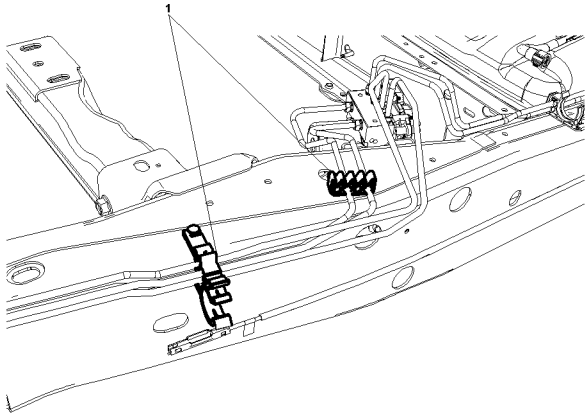

34. Release the front brake pipes assembly from the left frame rail clips (1).
35. Clean the area surrounding the brake pipe fittings on the BPMV thoroughly to remove all dirt and debris.

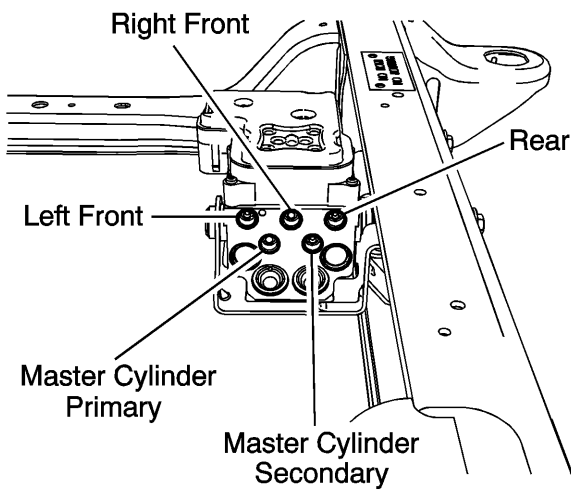

Note: Due to the similarity of the brake pipe fitting tube nuts, it is imperative to identify the individual brake pipe locations on the BPMV to ensure correct assembly.

36. For vehicles not equipped with RPO JL4, identify the brake pipe port locations at the BPMV prior to disconnecting the brake pipe fittings.

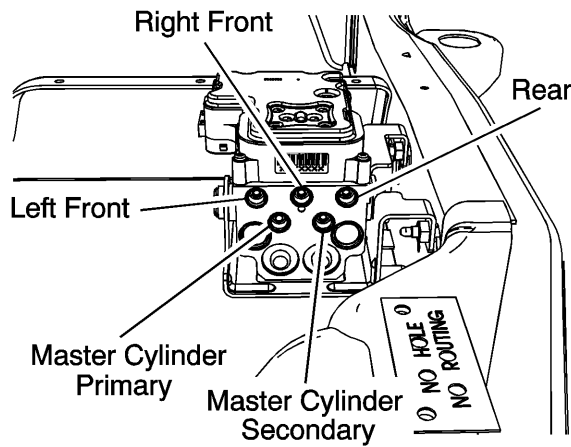

Note: Due to the similarity of the brake pipe fitting tube nuts, it is imperative to identify the individual brake pipe locations on the BPMV to ensure correct assembly.

37. For model year 2002 vehicles equipped with RPO JL4, identify the brake pipe port locations at the BPMV prior to disconnecting the brake pipe fittings.

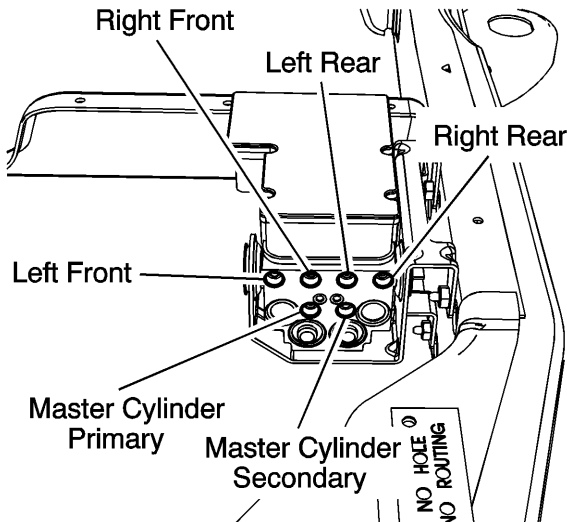

Note: Due to the similarity of the brake pipe fitting tube nuts, it is imperative to identify the individual brake pipe locations on the BPMV to ensure correct assembly.

38. For model year 2003-2008 vehicles equipped with RPO JL4, identify the brake pipe port locations at the BPMV prior to disconnecting the brake pipe fittings.

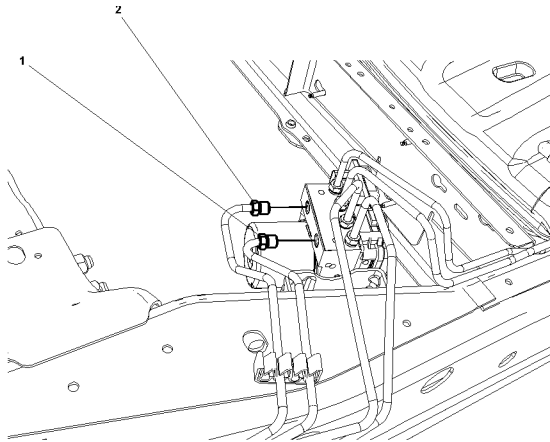

39. Using side cutters, cut the master cylinder primary (1) and secondary (2) brake pipes as close as possible to the brake pipe fitting at the BPMV.
 40. Using a 6 point socket, remove and discard the brake pipe fitting tube nuts.

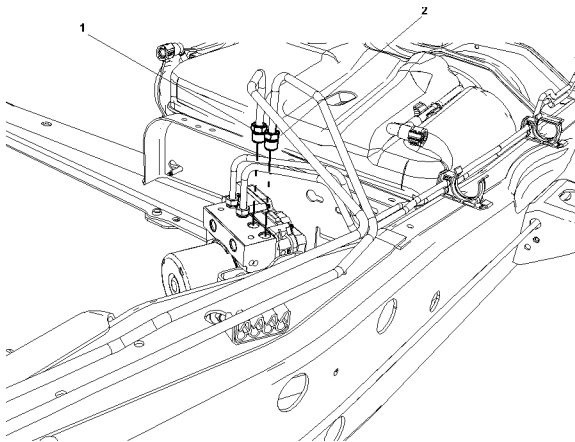

41. Using side cutters, cut the right front (1) and left front (2) brake pipes as close as possible to the brake pipe fittings at the BPMV.
 42. Using a 6 point socket, remove and discard the front brake pipe fitting tube nuts.
 43. Carefully remove the brake pipe routing clips from the front brake pipe assembly.

44. Maneuver the front brake pipes one at a time and remove the brake pipes from the vehicle.

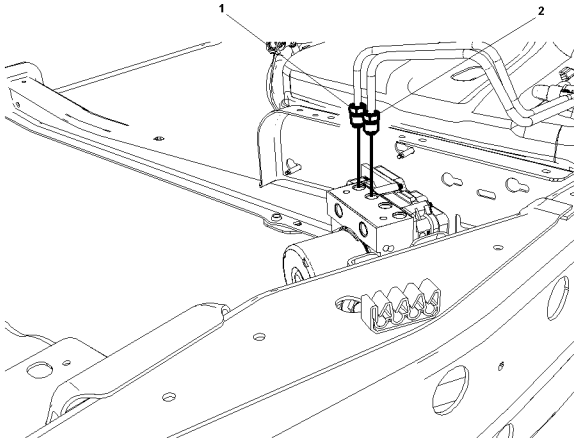

45. Using side cutters, cut the left rear (1) and right rear (2) brake front pipes as close as possible to the brake pipe fittings at the BPMV.
46. Using a 6 point socket, remove and discard the brake pipe fitting tube nuts.

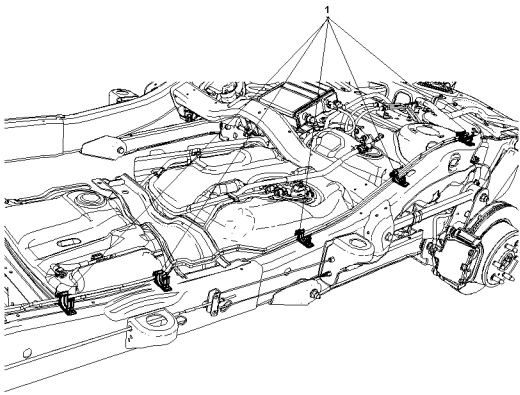

47. Release the rear brake pipes from the left frame rail clips (1).

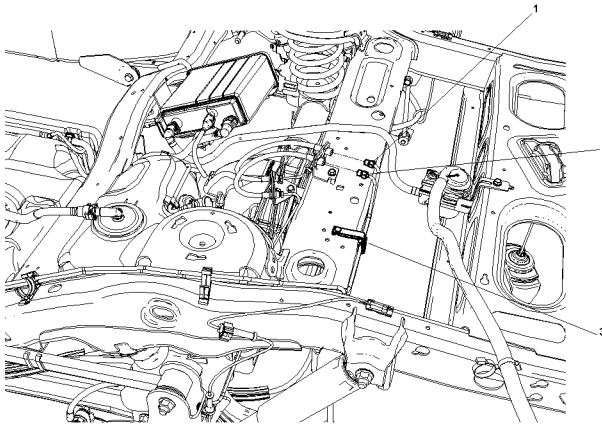

48. Using side cutters, cut the right rear (1) and left rear (2) brake pipes as close as possible to the brake pipe fittings at the rear brake frame to axle hose.
49. Release the rear brake pipes from the frame crossmember clip (3).
50. Using a 6 point socket, remove and discard the brake pipe fitting tube nuts.
51. Remove the rear brake pipes from the vehicle.

Installation

Caution: Use the correct fastener in the correct location. Replacement fasteners must be the correct part number for that application. Do not use paints, lubricants, or corrosion inhibitors on fasteners, or fastener joint surfaces, unless specified. These coatings affect fastener torque and joint clamping force and may damage the fastener. Use the correct tightening sequence and specifications when installing fasteners in order to avoid damage to parts and systems. When using fasteners that are threaded directly into plastic, use extreme care not to strip the mating plastic part(s). Use hand tools only, and do not use any kind of impact or power tools. Fastener should be hand tightened, fully seated, and not stripped.

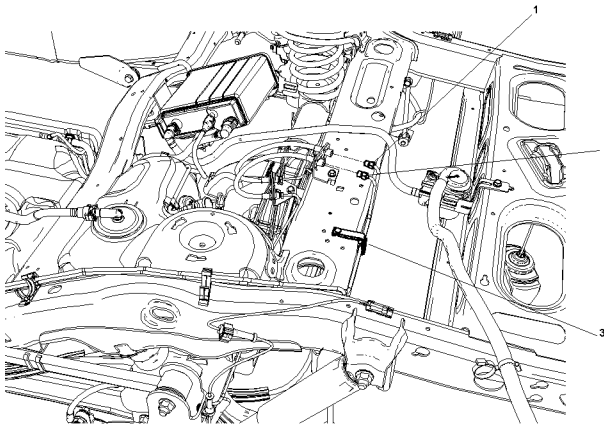

1. Install the rear brake pipes to the vehicle.
2. Install the right rear brake pipe fitting tube nut (1) to the rear brake frame to axle hose.
Tighten: Tighten the nut to 25 Y (18 lb ft)
3. Install the left rear brake pipe fitting tube nut (2) to the rear brake frame to axle hose.
Tighten: Tighten the nut to 25 Y (18 lb ft)
4. Install the rear brake pipes to the frame crossmember clip (3).

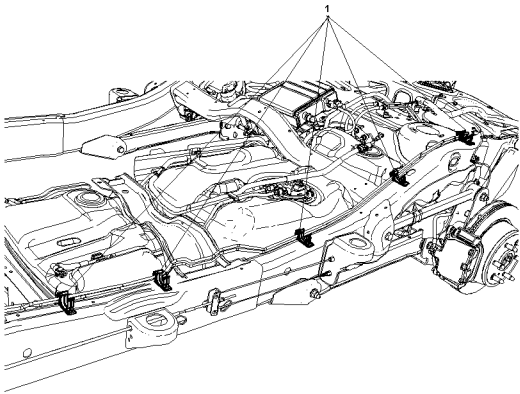

5. Install the rear brake pipes to the left frame rail clips (1).

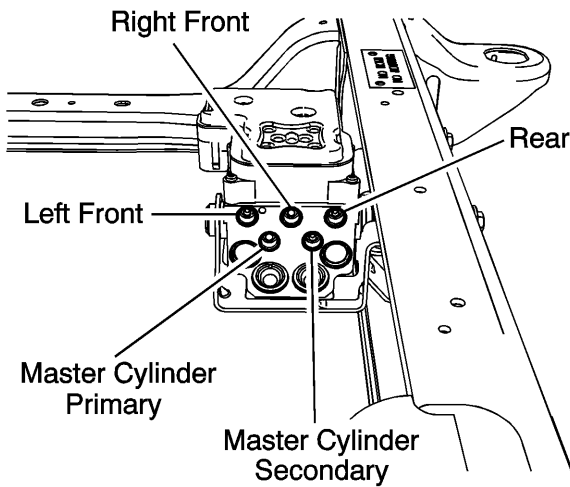

Note: Due to the similarity of the brake pipe fitting tube nuts, it is imperative to identify the individual brake pipe locations on the BPMV to ensure correct assembly.

6. For vehicles not equipped with RPO JL4, connect the brake pipe fittings to the BPMV port locations identified during removal.

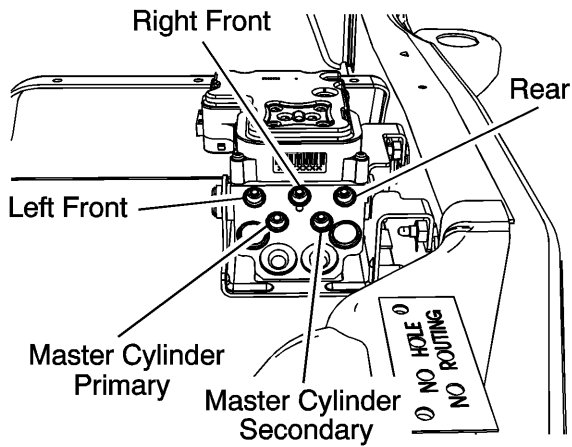

Note: Due to the similarity of the brake pipe fitting tube nuts, it is imperative to identify the individual brake pipe locations on the BPMV to ensure correct assembly.

- For model year 2002 vehicles equipped with RPO JL4, connect the brake pipe fittings to the BPMV port locations identified during removal.

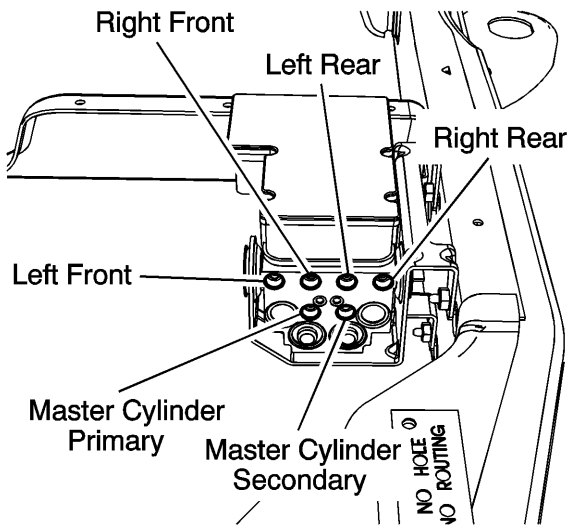

Note: Due to the similarity of the brake pipe fitting tube nuts, it is imperative to identify the individual brake pipe locations on the BPMV to ensure correct assembly.

- For model year 2003-2006 vehicles equipped with RPO JL4, connect the brake pipe fittings to the BPMV port locations identified during removal.

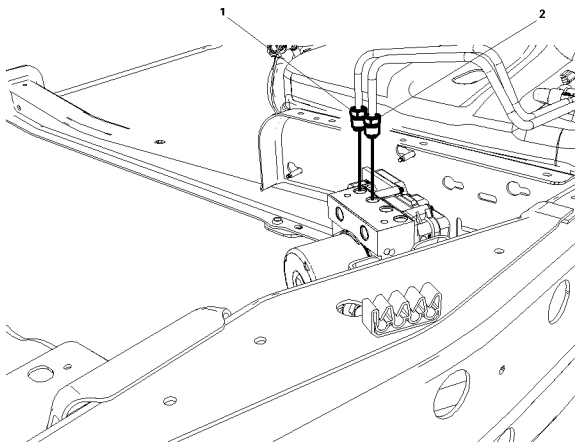

- Install the left rear brake pipe fitting tube nut (1) to the BPMV.

Tighten: Tighten the nut to 25 Y (18 lb ft)

10. Install the right rear brake pipe fitting tube nut (2) to the BPMV.

Tighten: Tighten the nut to 25 Y (18 lb ft)

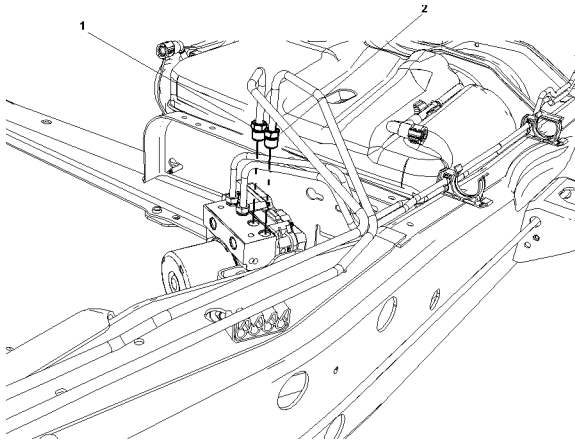

Note: Install the brake pipes to the routing clips and retaining clips after all the brake pipes are fitted to the vehicle.

11. Install the front brake pipes to the vehicle.
12. Install the left front brake pipe fitting tube nut (1) to the BPMV.
13. Install the right front brake pipe fitting tube nut (2) to the BPMV.

Tighten: Tighten the nut to 25 Y (18 lb ft)

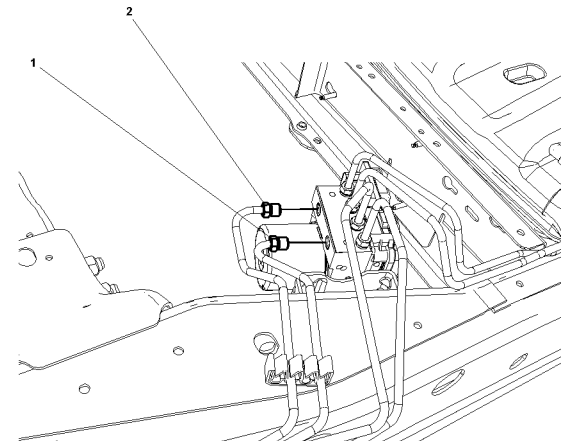

14. Install the master cylinder primary and secondary brake pipe assembly to the vehicle.
15. Install the master cylinder primary brake pipe fitting tube nut (1) to the BPMV.
16. Install the master cylinder secondary brake pipe fitting tube nut (2) to the BPMV.

Tighten: Tighten the nut to 25 Y (18 lb ft)

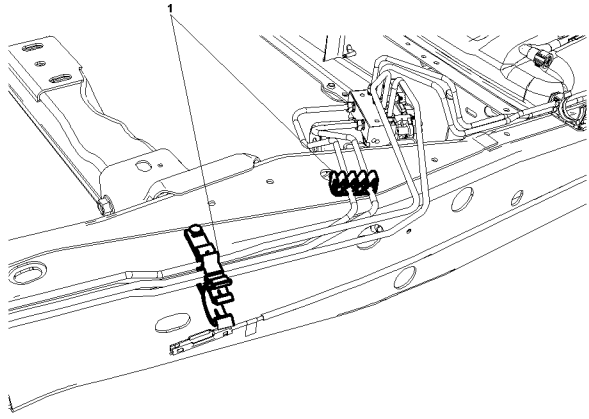

17. Install the front brake pipes assembly to the left frame rail clips (1).

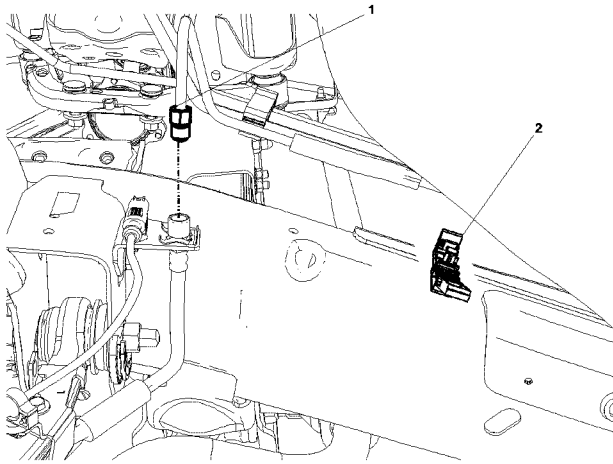

18. Install the left front brake pipe fitting tube nut (1).

Tighten: Tighten the nut to 25 Y (18 lb ft)

19. Install the front brake pipes assembly to the left frame rail clip (2).

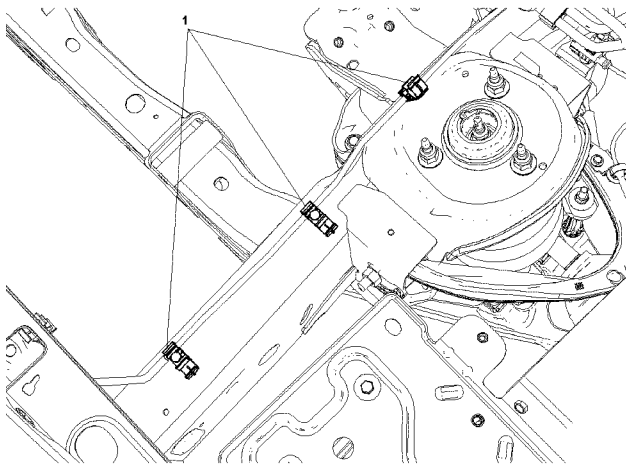

20. Install the right front brake pipe to the left front frame rail clips (1).

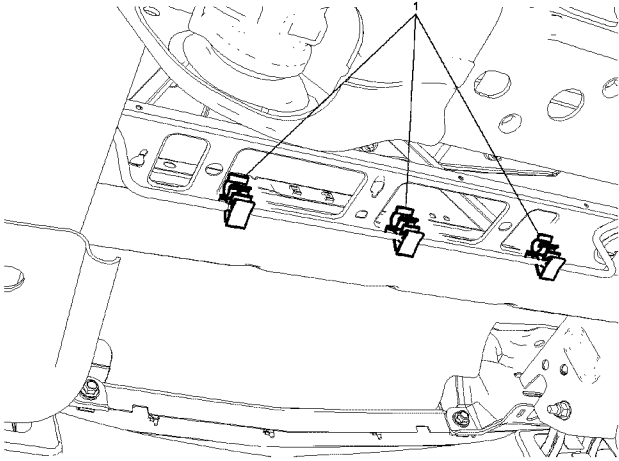

21. Install the right front brake pipe to the front frame crossmember clips (1).

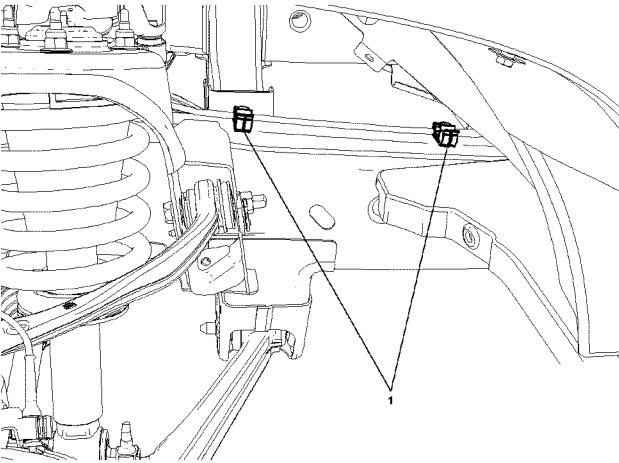

22. Install the right front brake pipe to the clips (1) on the right frame rail.

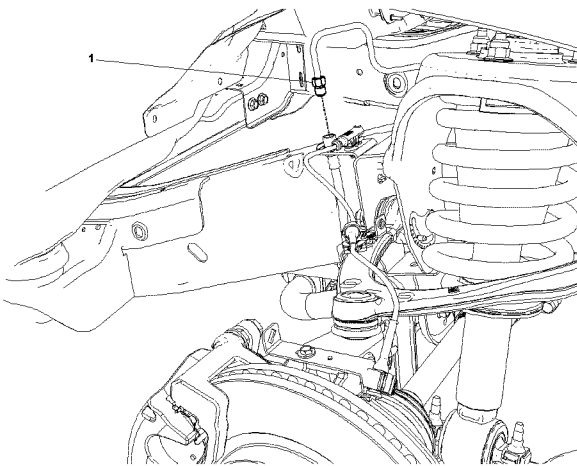

23. Install the right front brake pipe fitting tube nut (1).

Tighten: Tighten the nut to 25 Y (18 lb ft)

24. Reposition the body wiring harness into the brake pipe retaining clips.

25. Remove the blocks, lower the body and install the 6 left side body mount bolts. Refer to Drivetrain and Front Suspension Frame Insulator Replacement in SI.

26. Connect any wiring ground harnesses from the body to the frame. Refer to Power and Grounding Component Views in SI.
27. Connect the parking brake front cable. Refer to Parking Brake Front Cable Replacement in SI.
28. Connect the left front wheel speed sensor electrical connector and install the sensor harness retaining clips to the top of the left frame rail.
29. Install the engine protection shield, if equipped. Refer to Engine Protection Shield Replacement in SI.
30. Install the left and right front wheelhouse panels. Refer to Wheelhouse Panel Replacement in SI.
31. Lower the vehicle enough to access the combination valve and master cylinder brake pipe fittings.

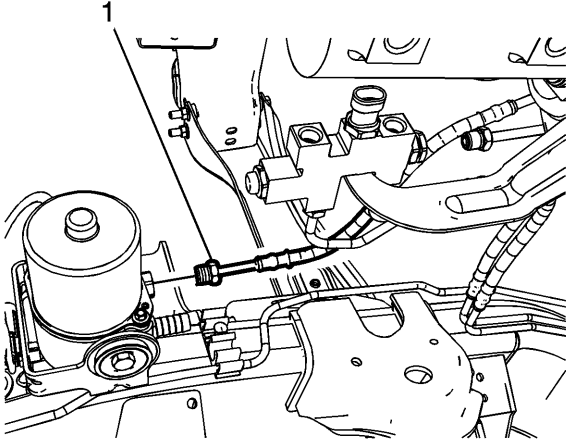

32. If equipped, connect the BPMV front brake pipe fitting (1) to the BPMV pre-charge pump.

Tighten: Tighten the brake pipe fitting to 25 Y (18 lb ft).

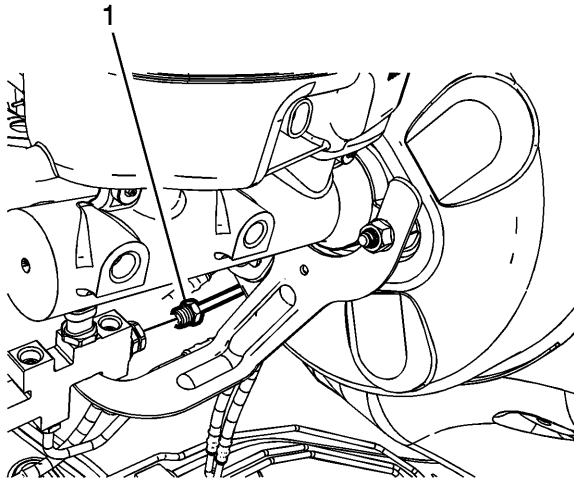

33. If equipped, connect the BPMV front brake pipe fitting (1) the combination valve.

Tighten: Tighten the brake pipe fitting to 25 Y (18 lb ft).

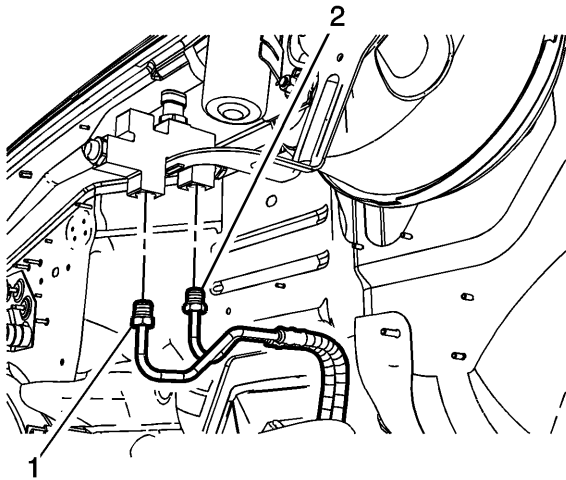

34. Connect the secondary (1) and primary (2) brake pipe fittings to the combination valve.

Tighten: Tighten the brake pipe fittings to 25 Y (18 lb ft).

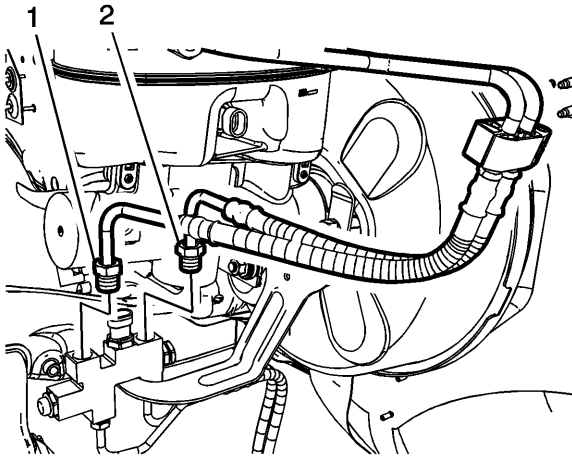

35. Connect the master cylinder secondary (1) and primary (2) brake pipe fittings to the combination valve.

Tighten: Tighten the brake pipe fittings to 25 Y (18 lb ft).

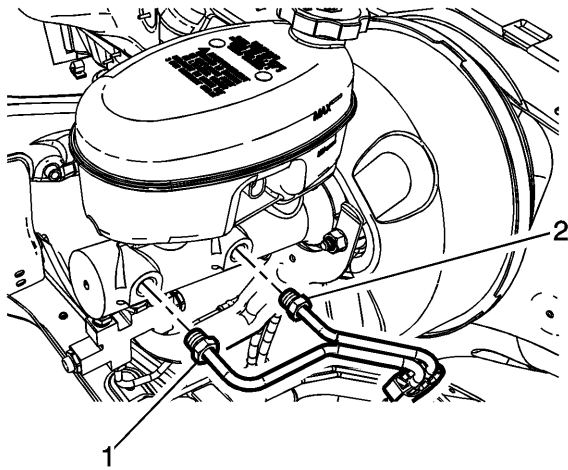

36. Connect the master cylinder secondary (1) and primary (2) brake pipe fittings to the master cylinder.

Tighten: Tighten the nut to 25 Y (18 lb ft)

37. Bleed the hydraulic brake system. Refer to Hydraulic Brake System Bleeding in SI

38. Install the front and rear tire and wheel assemblies. Refer to Tire and Wheel Removal and Installation in SI.

39. Raise the spare tire and wheel assembly into the stowed position.

Parts Information

Item	Model Years	C/K	Model	Option Usage	Front Suspension	Part Number
1	1999-2002	C	15703	&JC5	Coil Spring	22933207
2	2003-2004	C	15703	&JC3-JVA	Coil Spring	22932583
3	2005-2007	C	15703	&JF7	Coil Spring	22932609
4	1999-2002	C	15753	&JC5	Coil Spring	22933210
5	2003-2007	C	15753	&JC3/JC4/JH1-B2E/B4V	Coil Spring	23158907
6	2004	C	15753	&JC4&B2E/B4V	Torsion Bar	22932587
7	2003-2007	K	15753	&JC3/JC4/JH1	Torsion Bar	22932587
8	2005-2007	C	15753	&JF3/JF7-B2E/B4V/NHT	Coil Spring	22932601
9	2005-2007	C	15753	&B2E/B4V/NHT	Torsion Bar	22932596
10	2005-2007	K	15753	&JF3/JF7	Torsion Bar	22932596
11	1999-2002	C	15903	&JC5	Coil Spring	22933212
12	2003-2004	C	15903	&JC3	Coil Spring	22932584
13	2005-2007	C	15903	&JF7	Coil Spring	22932603

14	1999-2002	C	15953	&JC5	Coil Spring	22933214
15	2003-2004	C	15953	&JC3	Coil Spring	22932585
16	2005-2007	C	15953	&JF3/JF7	Coil Spring	22932604
17	2005-2007	C	15543	&JF3&B2E/B4V/BTN/NHT	Torsion Bar	22932597
18	2005-2007	K	15543	&JF3	Torsion Bar	22932597
19	2005-2007	C	15543	&JF3-B2E/B4V/BTN/NHT	Coil Spring	22932602
20	2006-2007	C	15553	&JF7	Torsion Bar	22932600
21	2006-2007	K	15553	&JF7	Torsion Bar	22932600
22	2004	C	15543	&JC4	Coil Spring	22936596
23	1999-2002	K	15703	&JC5	Torsion Bar	22933208
24	2003-2004	K	15703	&JC3	Torsion Bar	22932586
25	2005-2007	K	15703	&JF7	Torsion Bar	22932595
26	1999-2002	K	15753	&JC5	Torsion Bar	22933211
27	1999-2002	K	15903	&JC5	Torsion Bar	22933213
28	2003-2004	K	15903	&JC3	Torsion Bar	22932588
29	2005-2007	K	15903	&JF7	Torsion Bar	22932598
30	1999-2002	K	15953	&JC5	Torsion Bar	22933215
31	2003-2004	K	15953	&JC3	Torsion Bar	22932589
32	2005-2007	K	15953	&JF3/JF7	Torsion Bar	22932599
33	2004-2007	K	15543	&JC4	Torsion Bar	22932590
34	2001-2002	C	15743	&JH6	Torsion Bar	22933209
35	2001-2002	K	15743	&JH6	Torsion Bar	22933209
36	2003, 2005-2007	C	15743	&JH6	Torsion Bar	22932605
37	2003, 2005-2007	K	15743	&JH6	Torsion Bar	22932605
38	2004	C	25743	&JH6-HVY	Torsion Bar	22932605
39	2004	K	25743	&JH6-HVY	Torsion Bar	22932605
40	1999-2000	C	25753	&JH6	Coil Spring	22933202

41	1999-2000	C	25903	&JH6	Coil Spring	22933203
42	2001-2002	C	25903	&JH6-HVY	Torsion Bar	22933194
43	2003-2004	C	25903	&JH6-HVY	Torsion Bar	22932579
44	1999-2000	C	25953	&JH6	Coil Spring	22933204
45	1999-2002	K	25753	&JH6-HVY	Torsion Bar	22933193
46	1999-2000	K	25903	&JH6	Torsion Bar	22933194
47	2003-2004	K	25753	&JH6-HVY	Torsion Bar	22932578
48	1999-2000	K	25953	&JH6	Torsion Bar	22933205
49	2001-2002	C	25753	&JH6&HVY	Torsion Bar	22933188
50	2001-2002	K	25753	&JH6&HVY	Torsion Bar	22933188
51	2003-2007	C	25753	&JH6&HVY	Torsion Bar	22932574
52	2003-2007	K	25753	&JH6&HVY	Torsion Bar	22932574
53	2001-2002	C	25743	&JH6&HVY	Torsion Bar	22933187
54	2001-2002	K	25743	&JH6&HVY	Torsion Bar	22933187
55	2003-2007	C	25743	&JH6&HVY	Torsion Bar	22932565
56	2003-2007	K	25743	&JH6&HVY	Torsion Bar	22932565
57	2001-2002	C	25903	&JH6&HVY	Torsion Bar	22933189
58	2001-2002	K	25903	&JH6&HVY	Torsion Bar	22933189
59	2001-2002	C	35903	&JH6/JH7&HVY	Torsion Bar	22933189
60	2001-2002	K	35903	&JH6/JH7&HVY	Torsion Bar	22933189
61	2003-2007	C	25903	&JH6&HVY	Torsion Bar	22932567
62	2003-2007	K	25903	&JH6&HVY	Torsion Bar	22932567
63	2003-2007	C	35903	&JH6/JH7&HVY	Torsion Bar	22932567
64	2003-2007	K	35903	&JH6/JH7&HVY	Torsion Bar	22932567
65	2001-2002	C	25953	&JH6&HVY	Torsion Bar	22933191
66	2001-2002	K	25953	&JH6&HVY	Torsion Bar	22933191
67	2001-2002	C	35953	&JH6/JH7&HVY	Torsion Bar	22933191

68	2001-2002	K	35953	&JH6/JH7&HVY	Torsion Bar	22933191
69	2003-2007	C	25953	&JH6&HVY	Torsion Bar	22932569
70	2003-2007	K	25953	&JH6&HVY	Torsion Bar	22932569
71	2003-2007	C	35953	&JH6/JH7&HVY	Torsion Bar	22932569
72	2003-2007	K	35953	&JH6/JH7&HVY	Torsion Bar	22932569
73	2001-2002	C	25943	&JH6&HVY	Torsion Bar	22933190
74	2001-2002	K	25943	&JH6&HVY	Torsion Bar	22933190
75	2001-2002	C	35943	&JH6/JH7&HVY	Torsion Bar	22933190
76	2001-2002	K	35943	&JH6/JH7&HVY	Torsion Bar	22933190
77	2003-2007	C	25943	&JH6&HVY	Torsion Bar	22932568
78	2003-2007	K	25943	&JH6&HVY	Torsion Bar	22932568
79	2003-2007	C	35943	&JH6/JH7&HVY	Torsion Bar	22932568
80	2003-2007	K	35943	&JH6/JH7&HVY	Torsion Bar	22932568
81	2001-2002	C	36003	&JH7&HVY-JVA	Torsion Bar	22933198
82	2001-2002	K	36003	&JH7&HVY	Torsion Bar	22933198
83	2003-2007	C	36003	&JH7&HVY	Torsion Bar	22932570
84	2003-2007	K	36003	&JH7&HVY	Torsion Bar	22932570
85	2001-2002	C	36053	&JH7&HVY	Torsion Bar	22933199
86	2001-2002	K	36053	&JH7&HVY	Torsion Bar	22933199
87	2001-2002	C	36453	&JH7&HVY	Torsion Bar	22933199 Note (1)
88	2001-2002	K	36453	&JH7&HVY	Torsion Bar	22933199 Note (1)
89	2003-2007	C	36053	&JH7&HVY	Torsion Bar	22932571
90	2005-2006	C	36403	&JH7&HVY&WBZ	Torsion Bar	22932571 Note (2)
91	2003-2007	K	36053	&JH7&HVY	Torsion Bar	22932571

92	2005-2006	K	36403	&JH7&HVY&WBZ	Torsion Bar	22932571 Note (2)
93	2001-2002	C	36403	&JH7&HVY	Torsion Bar	22933200
94	2001-2002	K	36403	&JH7&HVY	Torsion Bar	22933200
95	2003-2005	C	36403	&JH7&HVY-WBZ	Torsion Bar	22932576
96	2003-2005	K	36403	&JH7&HVY-WBZ	Torsion Bar	22932576
97	2006-2007	C	36403	&JH7&HVY-WBZ	Torsion Bar	22932576
98	2006-2007	K	36403	&JH7&HVY-WBZ	Torsion Bar	22932576
99	2000-2002	C	15706	&JC5-JL4	Torsion Bar	22933217
100	2000-2002	K	15706	&JC5-JL4	Torsion Bar	22933217
101	2003-2006	C	15706	&JC4/JH2-JL4	Torsion Bar	22932593
102	2003-2006	K	15706	&JC4/JH2-JL4	Torsion Bar	22932593
103	2003-2006	C	15706	&JC4/JH2&JL4	Torsion Bar	22932591
104	2002	K	15706	&JH5&JL4	Torsion Bar	22933216
105	2003-2006	K	15706	&JC4/JH2&JL4	Torsion Bar	22932591
106	2000-2002	C	15906	&JC5-JL4	Torsion Bar	22933219
107	2000-2002	C	15936	&JC5-JL4	Torsion Bar	22933219
108	2000-2002	K	15906	&JC5-JL4	Torsion Bar	22933219
109	2000-2002	K	15936	&JC5-JL4	Torsion Bar	22933219
110	2003-2006	C	15906	&JC4/JH2-JL4	Torsion Bar	22932594
111	2003-2006	C	15936	&JC4/JH2-JL4	Torsion Bar	22932594
112	2003-2006	K	15906	&JC4/JH2-JL4	Torsion Bar	22932594
113	2003-2006	K	15936	&JC4/JH2-JL4	Torsion Bar	22932594
114	2002	K	15936	&JH5&JL4	Torsion Bar	22933218
115	2003-2006	C	15906	&JC4/JH2&JL4	Torsion Bar	22932592
116	2003-2006	C	15936	&JC4/JH2&JL4	Torsion Bar	22932592
117	2003-2006	K	15906	&JC4/JH2&JL4	Torsion Bar	22932592

118	2003-2006	K	15936	&JC4/JH2&JL4	Torsion Bar	22932592
119	2000	C	25906	&JH6	Coil Spring	22933206
120	2001-2002	C	25906	&JH6	Torsion Bar	22933197
121	2002	C	25936	&JH6	Torsion Bar	22933197
122	2000-2002	K	25906	&JH6	Torsion Bar	22933197
123	2002	K	25936	&JH6	Torsion Bar	22933197
124	2003-2006	C	25906	&JH6	Torsion Bar	22932582
125	2003-2006	K	25906	&JH6	Torsion Bar	22932582
126	2003-2006	C	25936	&JH6	Torsion Bar	22932582
127	2003-2006	K	25936	&JH6	Torsion Bar	22932582

Note (1): **22933199** kit will service the master cylinder to ABS module pipes, ABS to LF corner pipe, and ABS to RF corner pipe. The brake pipe from the ABS module to the rear axle jounce hose is designed for a 36053 model and will need to be cut in the straight section forward of the rear axle jounce hose fitting, the install P/N 11518522 tube nut and flare the end. Hand bend a section of GM P/N 88936298 nylon coated bulk pipe to match the original brake pipe rearward of the cut on the replacement brake pipe. Use the tube nut from the end of the replacement pipe for the attachment to the rear axle jounce hose fitting and use P/N 11518522 tube nut on the opposite (forward) end. Use P/N 11518687 Union to join the two brake pipe sections together. Torque Tube Nut P/N 11518522 to 25 N-m (18 lb-ft). The M12x1.0 Tube Nut (GM P/N 11518522, qty. 2), M12x1.0 Union (GM P/N 11518687, qty. 1), and GM P/N 88936298 PIPE, BRK (STEEL) (1/4" X 16 FT ROLL) bulk tubing are available separately through GM dealers.

Note (2): **22932571** kit will service the master cylinder to ABS module pipes, ABS to LF corner pipe, and ABS to RF corner pipe. The brake pipe from the ABS module to the rear axle jounce hose is designed for a 36053 model and will need to be cut in the straight section forward of the rear axle jounce hose fitting, the install P/N 11518522 tube nut and flare the end. Hand bend a section of GM P/N 88936298 nylon coated bulk pipe to match the original brake pipe rearward of the cut on the replacement brake pipe. Use the tube nut from the end of the replacement pipe for the attachment to the rear axle jounce hose fitting and use P/N 11518522 tube nut on the opposite (forward) end. Use P/N 11518687 Union to join the two brake pipe sections together. Torque Tube Nut P/N 11518522 to 25 N-m (18 lb-ft). The M12x1.0 Tube Nut (GM P/N 11518522, qty. 2), M12x1.0 Union (GM P/N 11518687, qty. 1), and GM P/N 88936298 PIPE, BRK (STEEL) (1/4" X 16 FT ROLL) bulk tubing are available separately through GM dealers.

2001–2002 C/K 36453&JH7&HVY (Brake Pipe Kit P/N 22933199)

Rear pipe modifications using rear pipe from Brake Pipe Kit, P/N 22933199:

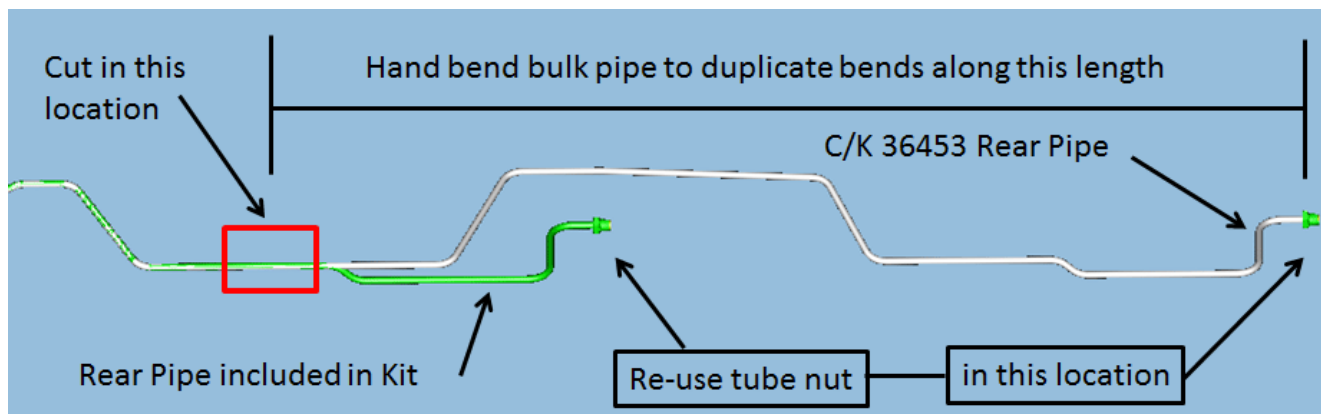

1. Cut rear pipe in approximate location as shown by red box
2. Install M12x1.0 tube nut 11518522 & flare end (double inverted)
3. Install union 11518687 onto tube nut
4. Hand bend bulk pipe GM P/N 88936298 to duplicate bends from the pipe removed from the vehicle from the union back to the rear axle jounce hose.

5. Install M12x1.0 tube nut 11518522 on end adjacent to union.
6. Re-use tube nut from section of removed pipe on end that attaches to rear axle jounce hose.
7. Torque tube nuts to 25 Y (18 lb ft).

2005–2006 C/K 36403&JH7&WBZ&HVY (Brake Pipe Kit P/N 22932571)

Rear pipe modifications using rear pipe from Brake Pipe Kit, P/N 22932571:

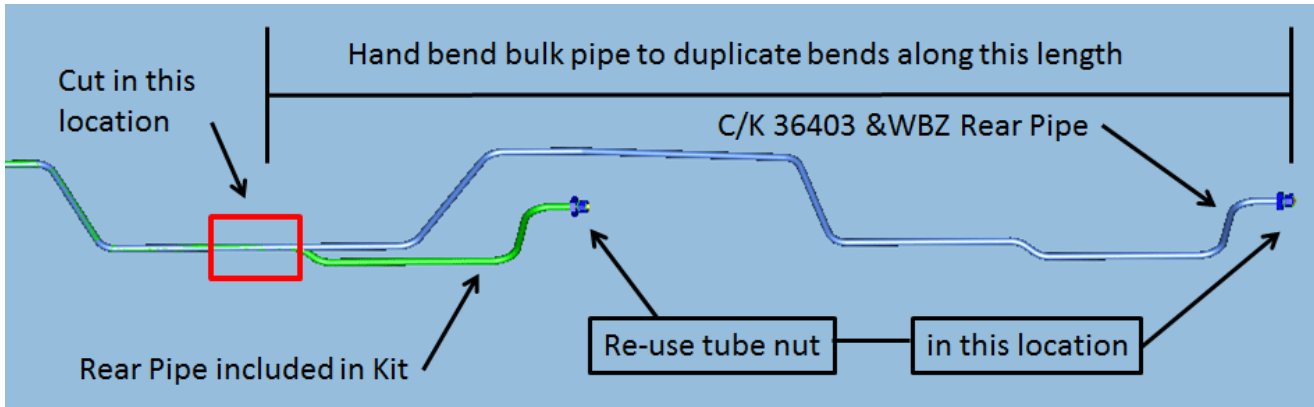

1. Cut rear pipe in approximate location as shown by red box
2. Install M12x1.0 tube nut 11518522 & flare end (double inverted)
3. Install union 11518687 onto tube nut
4. Hand bend bulk pipe GM P/N 88936298 to duplicate bends from the pipe removed from the vehicle from the union back to the rear axle jounce hose.
5. Install M12x1.0 tube nut 11518522 on end adjacent to union.
6. Re-use tube nut from section of removed pipe on end that attaches to rear axle jounce hose.
7. Torque tube nuts to 25 Y (18 lb ft).

GM bulletins are intended for use by professional technicians, NOT a "do-it-yourselfer". They are written to inform these technicians of conditions that may occur on some vehicles, or to provide information that could assist in the proper service of a vehicle. Properly trained technicians have the equipment, tools, safety instructions, and know-how to do a job properly and safely. If a condition is described, DO NOT assume that the bulletin applies to your vehicle, or that your vehicle will have that condition. See your GM dealer for information on whether your vehicle may benefit from the information.



WE SUPPORT VOLUNTARY TECHNICIAN CERTIFICATION