



# Service Bulletin

## PRELIMINARY INFORMATION

**Subject:** Transmission Fluid Leak at Auxiliary Pump Seal

**Models:** 2014 Chevrolet Malibu  
Equipped with 6T40 Automatic Transmission (RPO MNH)

*This PI has been revised to add the two important statements. Please discard PI1071.*

### Condition/Concern

Some customers may comment on a transmission leak.

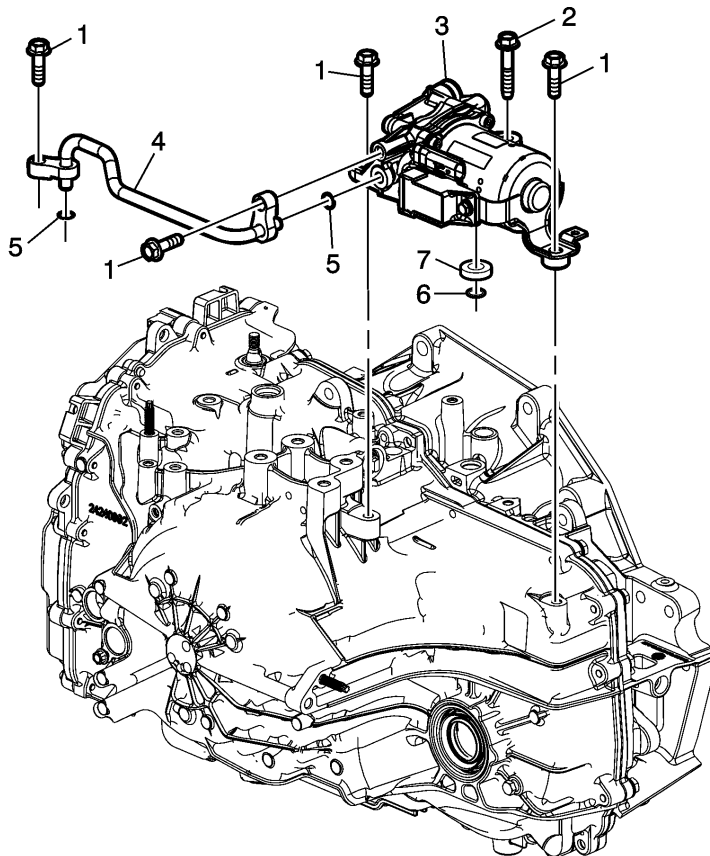

Investigation of the leak may show that the fluid is leaking on top of the transmission at the auxiliary fluid pump seal (6).

### Recommendation/Instructions

If leak diagnosis determines that the leak source is the auxiliary fluid pump seal, it should be replaced.

**Important:** To prevent damage to the replacement seal, be sure to lubricate the seal with transmission fluid before installing the auxiliary pump.

For replacement of the seal, refer to the Auxiliary Fluid Pump Replacement procedure in SI.

**Important:** The auxiliary pump seal should be checked for leaks after installation using the following steps.

1. Start the engine.
2. With the transmission in Park and the park brake applied, raise the engine speed to 4,000 RPM for at least 30 seconds.
3. After 30 seconds, shut off the engine and inspect the transmission for leaks in the area of the auxiliary pump.

### Parts Information

The seal can be obtained from the Warranty Parts Center (WPC). Please use the form at the end of this bulletin to order the part.

Part Number	Description	Qty
WPC# 735	Auxiliary Fluid Pump Seal	1

### Warranty Information

For vehicles repaired under warranty, use:

Labor Operation	Description	Labor Time
8463490	Auxiliary Fluid Pump Replacement	Use Published Labor Operation Time

**IMPORTANT NOTE WHEN PRINTING THIS FORM:** If the form prints out on two pages, make certain you fax BOTH pages so that the WPC receives all the needed information. Missing information will delay or prevent the part from being shipped.

<b>Parts Request Form – Warranty Parts Center</b>
---

**Use this form ONLY for U.S., Canadian and Mexico Dealers. Export markets located outside of North America must contact their regional Technical Assistance Center for assistance.**

To: Warranty Parts Center

e-mail: warrantypartscenterUSA@gm.com

or WPC Fax: 248-371-0192

Attn: Amina Winfrey

Part Being Requested: WPC #735 Auxiliary Fluid Pump Seal

Dealer BAC (U.S.) /Dealer Code (Canada)/Dealer Number (Mexico):

Dealer Name:

Dealer Address:

Dealer Contact Person:

Dealer Phone Number:

Repair Order Number:

Vehicle VIN:

**Important:** If you do not receive the part within 2 business days after e-mailing or faxing your part request to the Warranty Parts Center, please call WPC Customer Assistance at 248-371-9901/9902.

GM bulletins are intended for use by professional technicians, NOT a "do-it-yourselfer". They are written to inform these technicians of conditions that may occur on some vehicles, or to provide information that could assist in the proper service of a vehicle. Properly trained technicians have the equipment, tools, safety instructions, and know-how to do a job properly and safely. If a condition is described, DO NOT assume that the bulletin applies to your vehicle, or that your vehicle will have that condition. See your GM dealer for information on whether your vehicle may benefit from the information.



WE SUPPORT VOLUNTARY TECHNICIAN CERTIFICATION