

REFERENCE:	Nova Bus Manuals
SECTION:	09: Engine and cooling
RS N°:	MQR 7621-346
EFFECTIVE IN PROD.:	L647 (2012MR)

APPLICATION DEADLINE:	–
-----------------------	---

SUBJECT:	Radiator Assembly anchorage, surge tank cap and supply tank inlet connector
JUSTIFICATION:	New procedure for the radiator assembly anchorage levelling to optimize the filling of the coolant and surge tank cap N36242 replaced by N65114

LEVEL	DESCRIPTION	DIRECT CHARGES		TIME
		LABOUR	MATERIAL	
1	Leveling of the radiator assembly, replace surge tank cap and modify supply tank	Client	Client	7h15
2	–	–	–	–

MATERIAL

QTY	PART N°	REV.	DESCRIPTION	REPLACES PART N°
LEVEL 1				
1	N65114	–	Surge tank cap	N36242
1	N66783	–	Support LH Radiator Assembly	N43209-1
1	N66782	–	Support RH Radiator Assembly	N43209-2
4	N37749	–	Dual Clamp Tie	–
2	N66397	–	3/8" Spacer	–
8	N16891	–	Bolt	–
4	N66725	–	Spacer	–
2 ⁽¹⁾	N36496	–	Washer	–
4	N43343	–	Radiator Mount	–
1	0444620	–	Threaded Plug	–
1	N31906	–	45° Fitting	–
1 ⁽²⁾	–	–	Leveling Jig ⁽²⁾	–
1	N8900477	–	Supply Tank Gasket	–
1	N8900432	–	Half Coupling	–
⁽¹⁾ Quantity is an estimation. Quantity will be determined according to radiator supports leveling requirements.				
⁽²⁾ Contact your After-Sales Representative for part details and availability.				
LEVEL 2				
–	–	–	–	–

Materials will be available within 84 days. To order, please contact Prevost Parts by phone at 1-800-771-6682, by fax at 1-888-668-2555 or by email at prevostparts.commandes@volvo.com. Specify document number, quantity of parts required and shipping address.

REVISION HISTORY

REV.	DATE	CHANGE DESCRIPTION	WRITTEN BY
NR	2013MA17	Initial release	Luc Carignan

CLIENT	ORDER	ROAD NUMBER		VIN (2NVY/4RKY...)		QTY
		FROM	TO	FROM	TO	
Arrow Coach Line - Arkansas	L494	—	—	L82U793000397	L82U793000397	1
BC Transit - BCT - British Columbia	L463	9319	9333	L82U093000273	L82U093000287	15
BC Transit - BCT - British Columbia	L481	9334	9353	L82U794000004	L82U094000023	20
BC Transit - BCT - British Columbia	L484	9370	9403	L82U494000090	L82U494000123	34
BC Transit - BCT - British Columbia	L486	9354	9369	L82U294000024	L82U494000039	16
BC Transit - BCT - British Columbia	L487	9404	9433	L82U094000149	L82U794000178	30
Belleville Transit - Ontario	L542	—	—	L82UXA3000088	L82U8A3000090	3
Brampton - Ontario	L501	0917	0921	L82U893000506	L82UX93000510	5
Brampton - Ontario	L501	0922	0926	L82U693000519	L82U893000523	5
CMBC (TransLink) - British Columbia	L532	9543	9551	L82U093000497	L82U693000505	9
CMBC (TransLink) - British Columbia	L533	9552	9559	L82U193000511	L82U493000518	8
CMBC (TransLink) - British Columbia	L533	9560	9573	L82U093000524	L82U093000537	14
CMBC (TransLink) - British Columbia	L534	9574	9589	L82U694000124	L82U894000139	16
CMBC (West Vancouver) - British Columbia	L539	901	909	L82U494000140	L82U994000148	9
Demo - Articulated Bus	L433	—	—	S92UX93000029	S92UX93000029	1
Demo - Plateforme 2010 (ATQ)	L456	—	—	L82U893000019	L82U893000019	1
Grand River Transit - GRT - Ontario	L464	20901	20913	L82U193000296	L82U493000308	13
Grand River Transit - GRT - Ontario	L560	21001	21009	L82U2A3000246	L82U1A3000254	9
Greater Toronto Airports Authority - GTAA - Ontario	L432	432-1	432-1	L82U793000061	L82U793000061	1
Greater Toronto Airports Authority - GTAA - Ontario	L477	L477-1	L477-1	L82U194000001	L82U194000001	1
Honolulu - Hawaii	L559	201	224	L82U6A4000113	L82U7A4000136	24
Lethbridge - Alberta	L489	165	169	L82U493000454	L82U193000458	5
New York City Transit - New York	L536	1200	1201	S92U793000490	S92U993000491	2
New York City Transit - New York	L545	1202	1203	S92U5A4000001	S92U7A4000002	2
New York City Transit - New York	L545	1204	1289	S92U1A4000013	S92U0A4000098	86
Niagara Falls - Ontario	L499	2986	2989	L82U093000564	L82U693000567	4
Peterborough - Ontario	L490	—	—	L82UX93000345	L82U593000348	4
Regina - Saskatchewan	L476	625	628	L82U893000313	L82U393000316	4
Regina - Saskatchewan	L561	631	638	L82U8B4000003	L82U5B4000010	8

CLIENT	ORDER	ROAD NUMBER		VIN (2NVY/4RKY...)		QTY
		FROM	TO	FROM	TO	
Regina - Saskatchewan	L561	639	644	L82U4B4000013	L82UXB4000018	6
Saskatoon - Saskatchewan	L551	1005	1007	S92UXA3000178	S92U8A3000180	3
St. John's - Newfoundland	L503	1066	1066	L82U4A3000071	L82U4A3000071	1
Stratford - Ontario	L493	—	—	L82U2A3000019	L82U2A3000019	1
Strathcona County Transit - Alberta	L523	2010	2010	L82U693000603	L82U693000603	1
Sudbury - Ontario	L465	791	795	L82U593000317	L82U793000321	5
Sudbury - Ontario	L552	801	808	L82U3A3000238	L82U0A3000245	8
Thunder Bay - Ontario	L488	—	—	L82U193000332	L82U593000334	3
Timmins - Ontario	L475	—	—	L82U493000311	L82U693000312	2
Timmins - Ontario	L550	—	—	L82U8A3000171	L82UXA3000172	2
University of Alabama - Alabama	L479	479-1	479-1	L82U394000002	L82U394000002	1
University of Alabama - Alabama	L480	480-1	480-1	L82U594000003	L82U594000003	1
University of Alabama - Alabama	L573	—	—	L82U9A4000137	L82U0A4000138	2
University of Colorado - Colorado	L427	—	—	S92U693000027	S92U693000027	1
University of Colorado - Colorado	L428	—	—	S92U893000028	S92U893000028	1
Walt Disney World - Florida	L535	1204	1213	L82UXA4000003	L82U0A4000012	10
Whitehorse - Yukon	L563	38	41	L82U3A3000255	L82U9A3000258	4
Woodstock - Ontario	L460	—	—	L82U693000309	L82U693000309	1
Woodstock - Ontario	L492	—	—	L82U4A3000040	L82U6A3000041	2

**WARNING**

Follow your internal safety procedures.

PROCEDURE

1.1. Remove the radiator access door. Retain the hardware. See Figure 1.

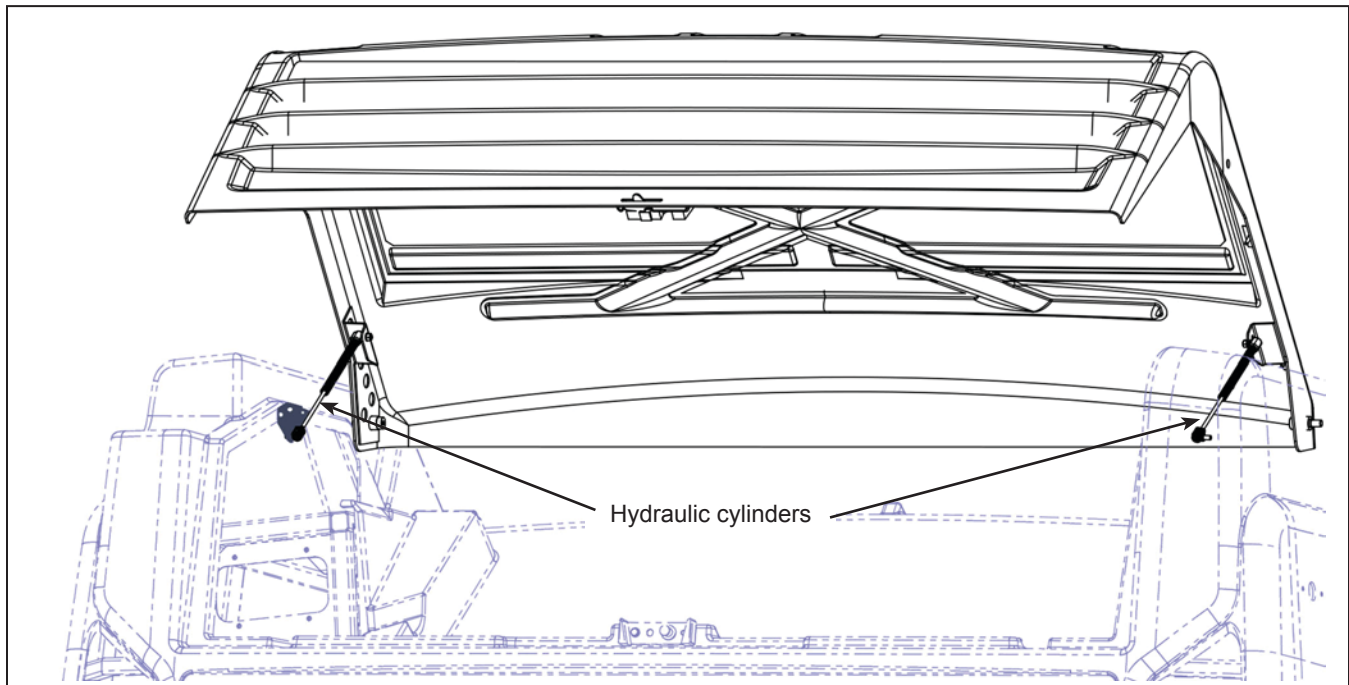

Figure 1 - Typical Anchorage for the Radiator Access Door

**WARNING**

Before starting any work on the radiator, make sure the vehicle is completely stationary. Isolate the engine starting circuit from the control box located at the rear of the vehicle.

Cleanliness is vital when working on the hydraulic system.

- 1.2. Remove the surge tank cap.
- 1.3. Install the new cap N65114 on the surge tank.
- 1.4. Open the engine access door.
- 1.5. Fill the cooling system according to filling procedure of section 09-302: **ENGINE COOLING** of the Nova Bus Maintenance Manual.
- 1.6. Close the stop valve to isolate the engine and heating cooling circuit.
- 1.7. Connect a regulator valve equipped with a pressure gauge on the quick connect fitting.

- 1.8. Adjust the pressure to 15 psi and close air pressure inlet. Make sure the pressure remains constant for 5 minutes.
- 1.9. If the pressure does not remain constant verify if liquid and/or air is leaking from the overflow hose.
 - 1.9.1. If liquid and/or air leaks from the overflow hose, perform steps 1.35 to 1.38 for the replacement of the surge tank and order a new surge tank N56950.
 - 1.9.2. If there is no liquid and/or air leaking from the overflow hose, proceed with the proper correction to repair the engine cooling.
- 1.10. Drain the various fluids from the hydraulic and cooling circuit, disconnect the piping to the radiator, and remove the radiator assembly according to the drain and removal procedures of sections 09-304: **HYDRAULIC SYSTEM** and 09-302: **ENGINE COOLING** of the Nova Bus Maintenance Manual.
- 1.11. Place the radiator assembly in a secure and accessible area.
- 1.12. Remove the isolators from the support. Retain the hardware. See Figure 2

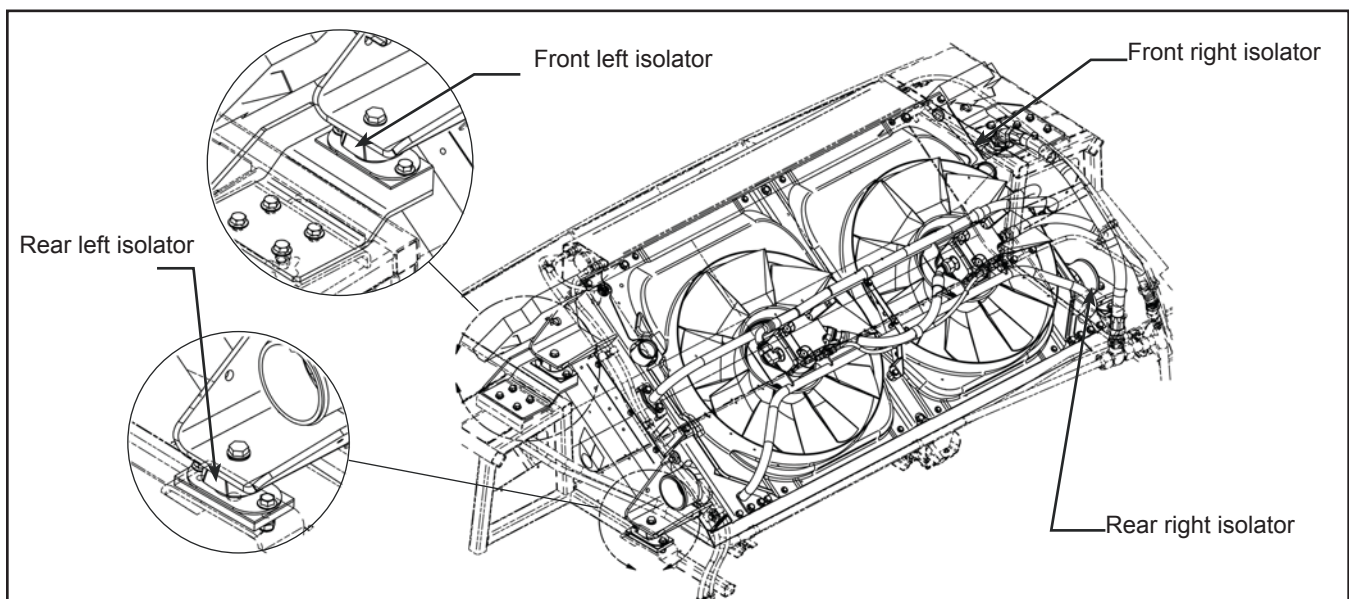

Figure 2 - Isolators Identification

- 1.13. Move the cooling fluid pipe located on the left side of the vehicle in order to avoid contact with the leveling jig. It is recommended to remove the rear light panels located on each side of the rear shell to gain access to the piping anchor points.

- 1.14. Replace the front supports with new upper supports N66783 (left support) and N66782 (right support) using the retained mounting bolts. Apply Loctite 242 thread locker or the equivalent to the bolts . See Figure 3.

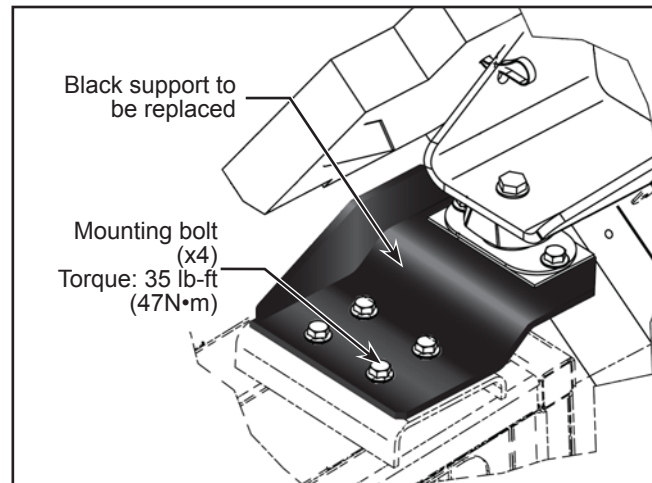

Figure 3 - Upper Black Support (Left Side Shown/ Right Side Similar)

- 1.15. Make sure that the hydraulic pipe brackets, located in rear portion of the radiator compartments are still bonded to the rear shell. See Figure 4.

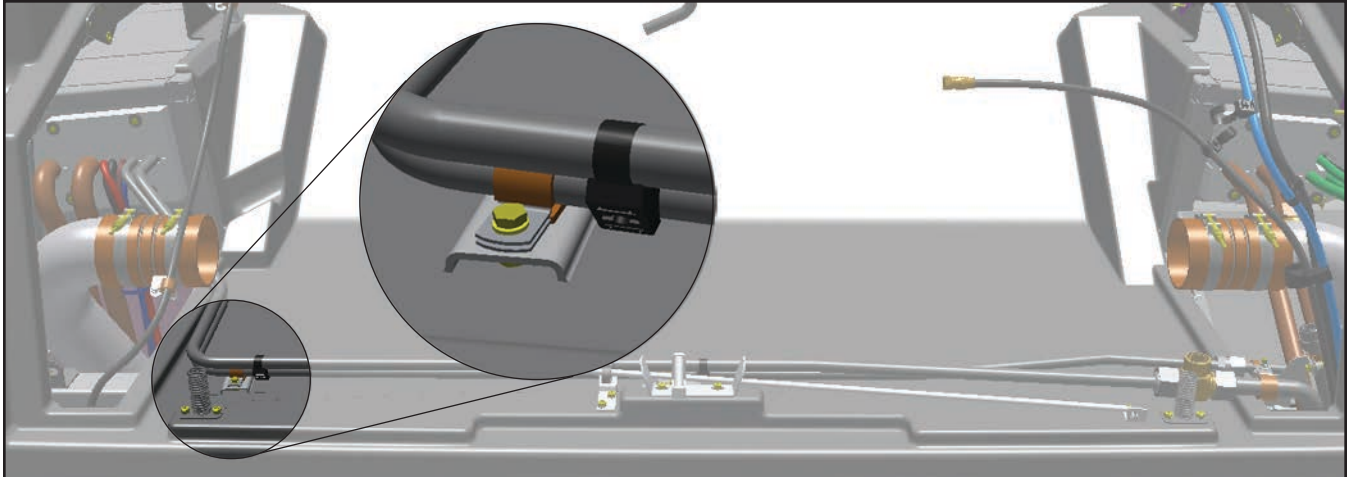

Figure 4 - Hydraulic Pipe Brackets

- 1.16. Wipe clean the fiberglass surface located beneath the radiator and if needed under the hydraulic pipe bracket, then inspect the surface for any wear or damage caused by the radiator rubber guard and the hydraulic piping support . The fiberglass or gelcoat surface might be damaged, grooved or perforated.
 - 1.16.1. If the surface is lightly damaged apply epoxy resin to repair in such a way to obtain a smooth and uniform surface. Refer to section 01 : **BODY** of the Nova Bus LFS maintenance manual for fiberglass and gelcoat repair instructions. See Figure 5.
 - 1.16.2. If the surface is grooved or perforated, install a thin plate of stainless steel to cover the damaged fiberglass or gelcoat. Refer to section 01 : **BODY** of the Nova Bus LFS maintenance manual for fiberglass and gelcoat repair instructions. See Figure 6.

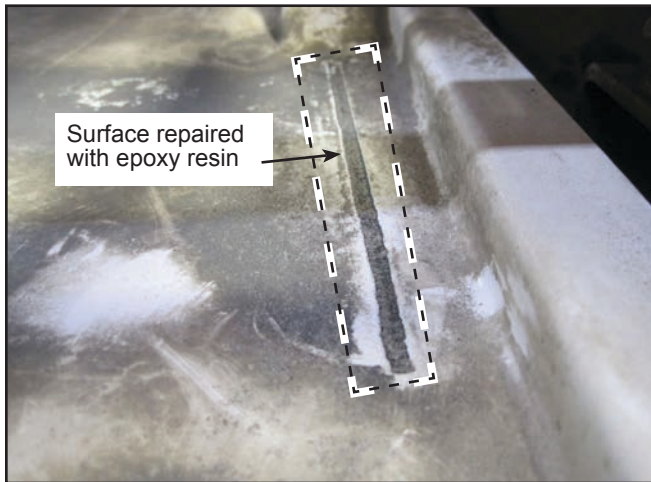

Figure 5 - Surface Damage Repaired with Epoxy Resin



Figure 6 - Severe Damages Repaired with a Stainless Steel Plate.

- 1.17. Using Sikaflex 252, bond the hydraulic pipe brackets to the fiberglass surface. If needed, apply a thicker coat of Sikaflex 252 to fill the gap between the bracket and repaired surface. Refer to section 01-000: **BODY** of the Nova Bus maintenance manual for fiberglass surface repair instructions.
- 1.18. Secure the hydraulic pipes to the brackets. If there is contact between the two pipes, separate them with double-ring tiewraps N37749.

- 1.19. Install a 3/8" spacer, N66397 and new isolator N43343 using N16891 bolts and retained hardware on both rear supports of the structure. Apply Loctite 242 thread locker or the equivalent on the bolts. Do not tighten the bolts. See Figure 7.

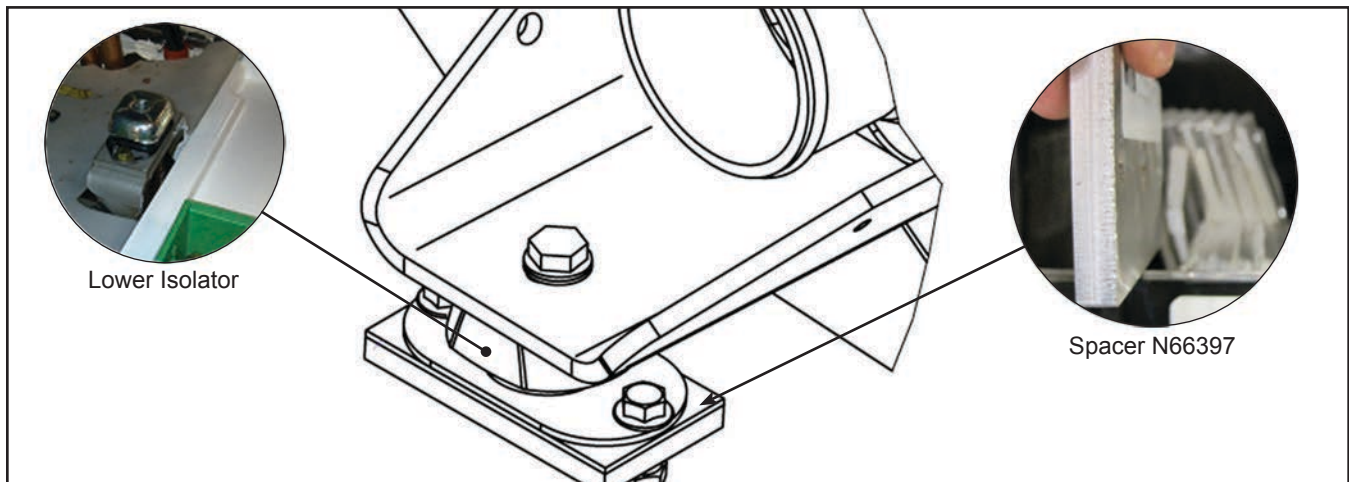

Figure 7 - Installation of Spacers N66397 on the Lower Supports

- 1.20. Install new isolator N43343 on the front support. Apply Loctite 242 thread locker or the equivalent on the bolts. Do not tighten the bolts.
- 1.21. Install the leveling jig onto the isolators. Secure the jig to the isolators with the centering pins. See Figure 8.



Figure 8 - Leveling Jig

- 1.22. Ensure the jig is level and sits properly on both lower isolators. If there is a gap between the jig and the upper isolators, insert one or a few thin spacers (N66725) or a combination of thin and thick spacers (N66397) in order to fill the gap.
- 1.23. Remove the leveling jig and place in a secure area.
- 1.24. Remove the bolts and isolators which require leveling.
- 1.25. Place the spacers measured with the leveling jig between the support and the isolator. The retained bolts might be too short due to the new spacer. If needed use N16891 bolts in a way to obtain two thread beyond the nuts.
- 1.26. Ensure proper installation by mounting the leveling jig onto the isolators. The jig should sit properly on all four isolators. If needed add or remove spacers to readjust.
- 1.27. Begin tightening the bolts according to the following sequence:
 - 1.27.1. Tighten the rear bolt of the upper left isolator.
 - 1.27.2. Tighten the rear bolt of the lower right isolator.
 - 1.27.3. Tighten the rear bolt of the lower left isolator.
 - 1.27.4. Tighten the rear bolt of the upper right isolator.
 - 1.27.5. Repeat the sequence for the front bolt of all four isolators.
- 1.28. Remove the levelling jig and set aside in a secure area.
- 1.29. Repeat the tightening sequence of step 1.27 by applying a tightening torque of 35 ft-lb (47N•m) on the isolator bolts. See Figure 13.
- 1.30. Remove the radiator spider assembly and the shroud from the radiator. See Figure 9.

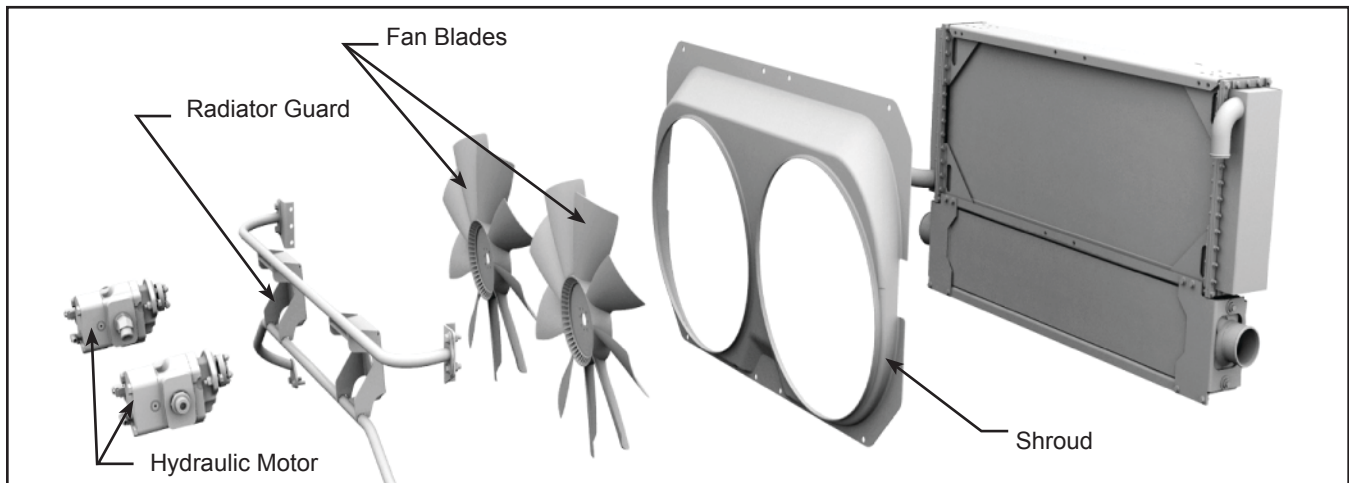

Figure 9 - Radiator Assembly

- 1.31. Remove the left support from the radiator. Retain the support and the hardware.
- 1.32. Disconnect the inlet hose from the radiator inlet reservoir. See Figure 10.
- 1.33. Number the position of the radiator inlet reservoir bolts located on radiator left side to ease the installation of the inlet reservoir after its modification. See Figure 10.
- 1.34. Remove the inlet reservoir from the radiator and remove the gasket. Retain the hardware. See Figure 10.

**NOTE**

Steps 1.35 to 1.38 should be performed only if the pressure test in step 1.9 shows a leak on the surge tank.

- 1.35. Remove the surge tank from the radiator. Retain the hardware and the new cap N65114. See Figure 10.
- 1.36. Remove all the parts installed on the removed surge tank.
- 1.37. Install the parts removed from the old surge tank on the new surge tank. Respect the original orientation of the parts.
- 1.38. Install the new surge tank equipped with cap N65114 on the radiator using the retained hardware. See Figure 10.

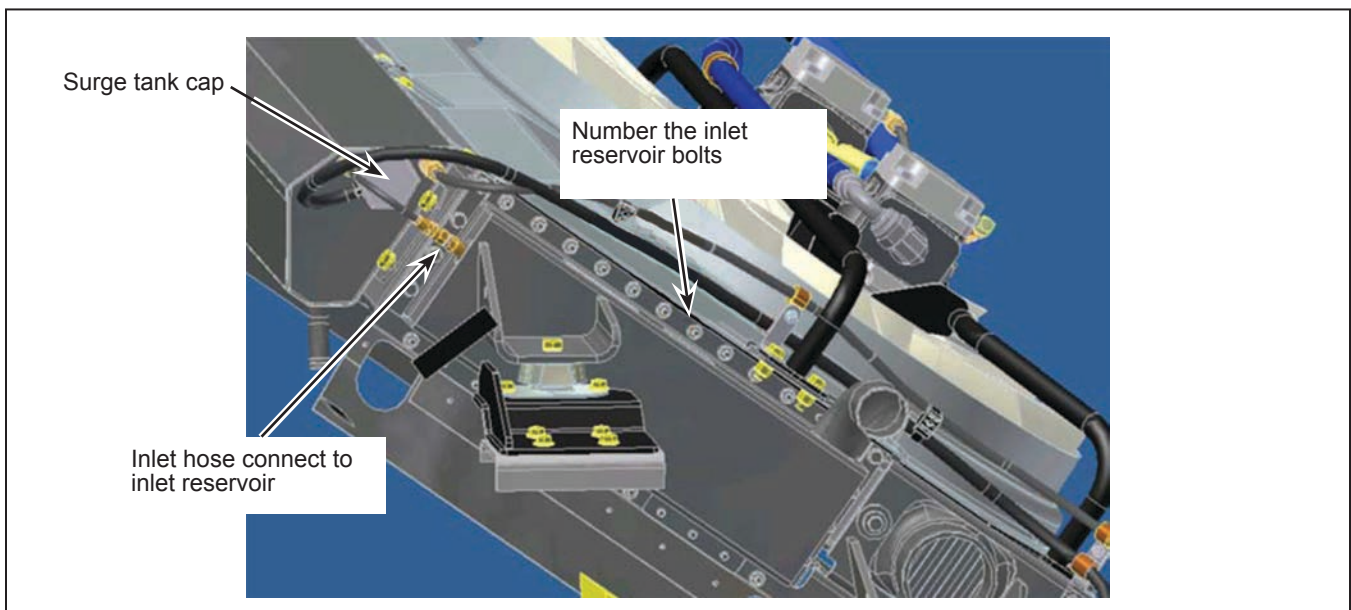

Figure 10 - Inlet Reservoir Installed on the Radiator

- 1.39. Drill a 1/2 in. (13 mm) diameter hole on the inlet reservoir. See Figure 11 for the location of the hole to drill.
- 1.40. Center the half coupling N8900432 on the drilled hole of the inlet reservoir and weld the entire contour.
- 1.41. Install the modified inlet reservoir and gasket N8900477 on the radiator using the retained hardware. Tighten the bolts from the center of the inlet reservoir to the extremity respecting bolts position as per their numbering.
- 1.42. Install the left support on the radiator using the retained hardware.
- 1.43. Apply a thin coat of thread sealant on the 45° fitting N31906 and the threaded plug 0444620.
- 1.44. Install the 45° fitting N31906 on the half coupling N8900432. See Figure 11.
- 1.45. Connect the inlet hose to the 45° fitting N31906. See Figure 11.
- 1.46. Replace the old inlet fitting with the threaded fitting 0444620. See Figure 11.

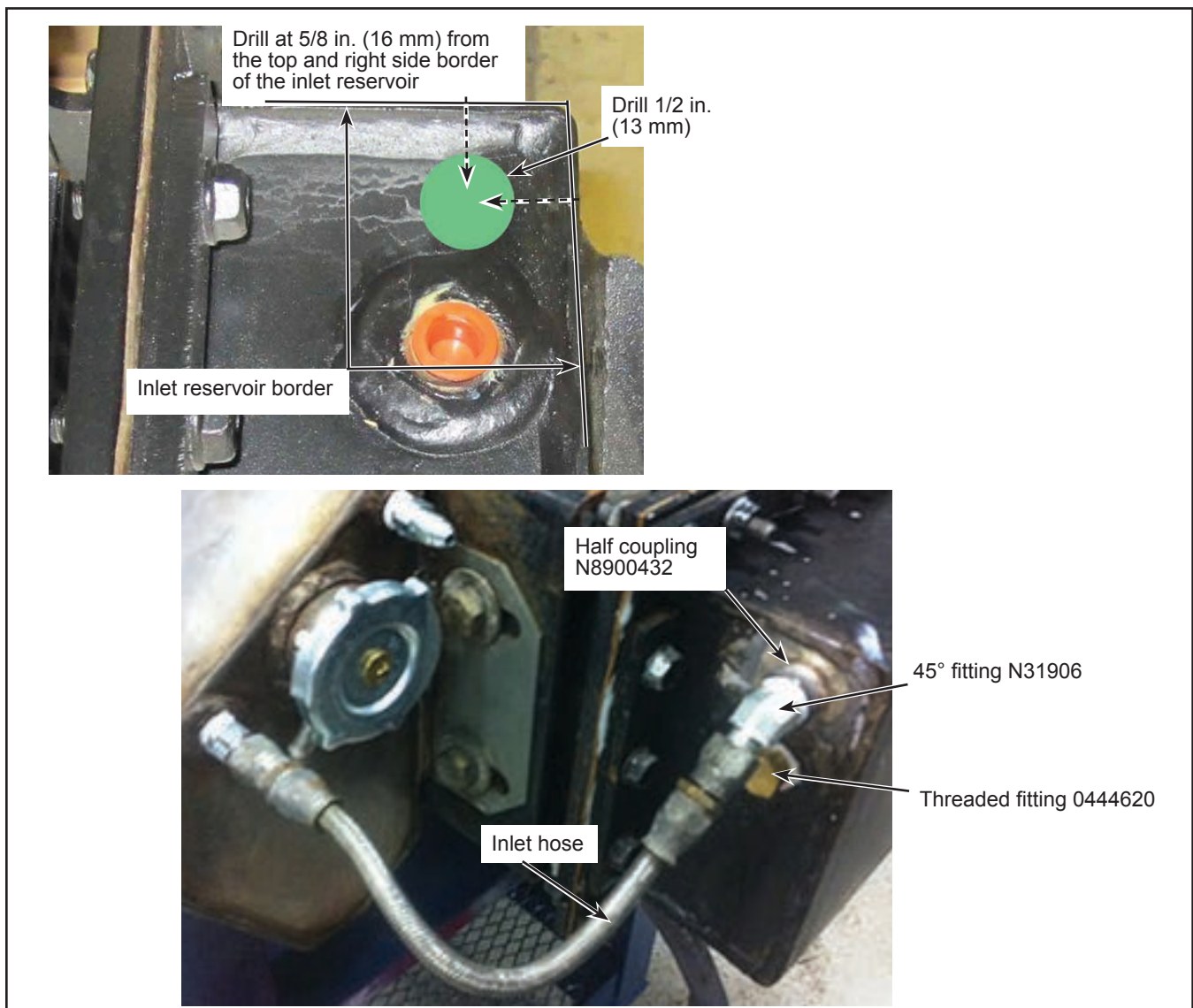

Figure 11 - Inlet Reservoir

- 1.47. Install the spider and the shroud on the radiator. Adjust the spacing between the internal contour of the shroud and the fan blades in such a way to obtain 3/16 in. (5 mm) clearance. Tighten the shroud bolts once the spacing is adjusted and torque the spider anchor bolts. See Figure 12.

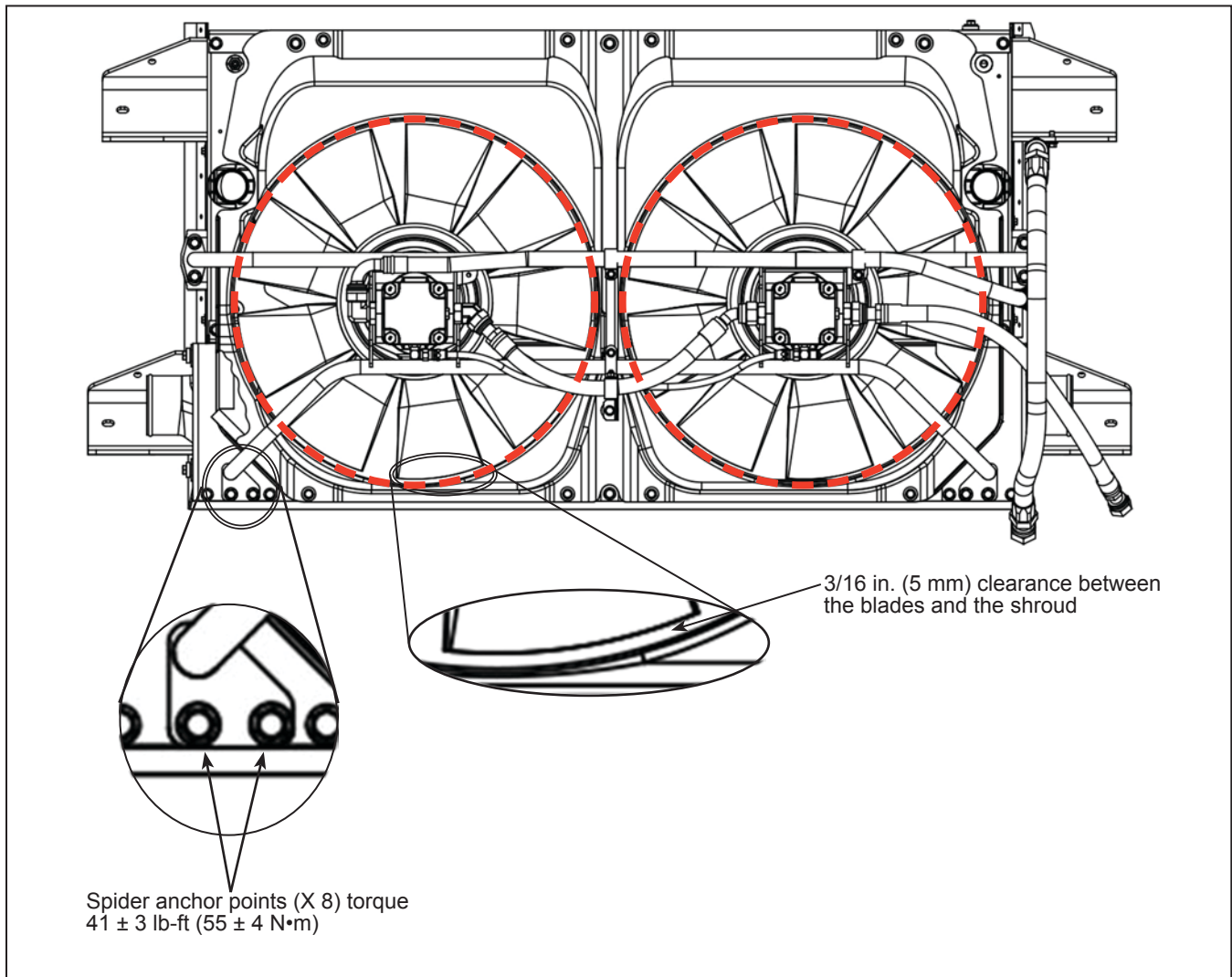

Figure 12 - Torque of the Spider and Spacing Between the Shroud and the Blades

- 1.48. Install the radiator on the new isolator.
- 1.49. Make sure the radiator supports rest correctly on the new isolator. The radiator frame might be slightly twisted or the radiator support might be a bit uneven. If that is the case, fill the gap between the isolator and the radiator support with washers N36496.

**NOTE**

Radiator mounting support holes and isolators might not align correctly. To obtain proper alignment, loosen the isolator anchor bolts and move the isolator in such a way to line up with the mounting support holes. Torque the isolator anchor bolts to 35 ± 3 lb-ft (47 ± 4 N•m). See Figure 13.

- 1.50. Apply Loctite 242 thread locker or the equivalent on the radiator's anchor bolts.
- 1.51. Place the anchor bolts and pre-tighten.
- 1.52. Apply the torque specified in Figure 13.

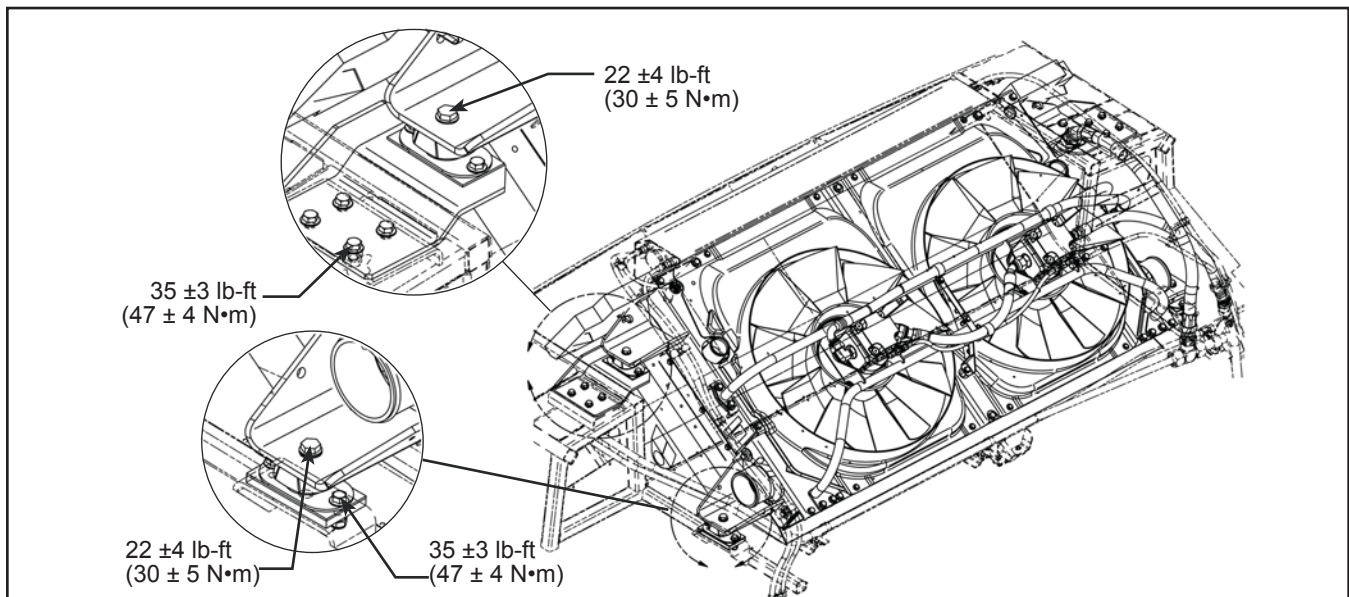

Figure 13 - Radiator Installation and Torque Value

- 1.53. Connect all the hoses and accessories on the radiator.

**NOTE**

Install and tighten the piping according to the procedure indicated in section 99 : GENERAL PRACTICES of the Nova Bus LFS maintenance manual and as indicated in Figures 14 to 16.

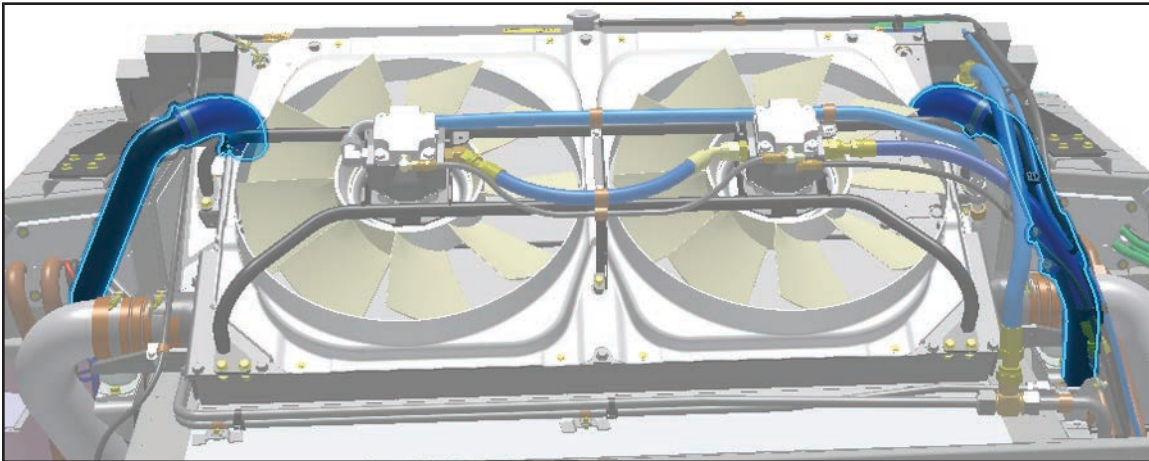

Figure 14 - Cooling System Piping

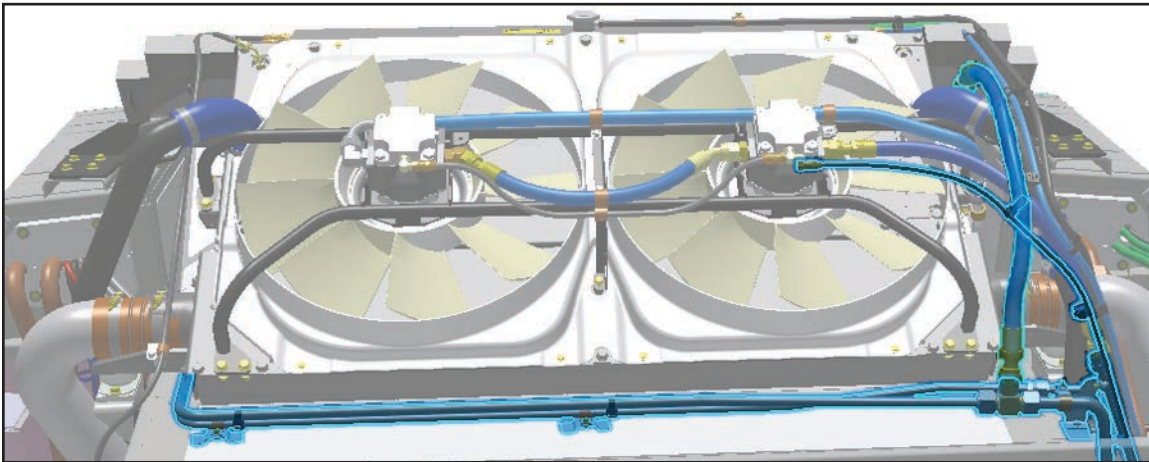

Figure 15 - Hydraulic System Lines

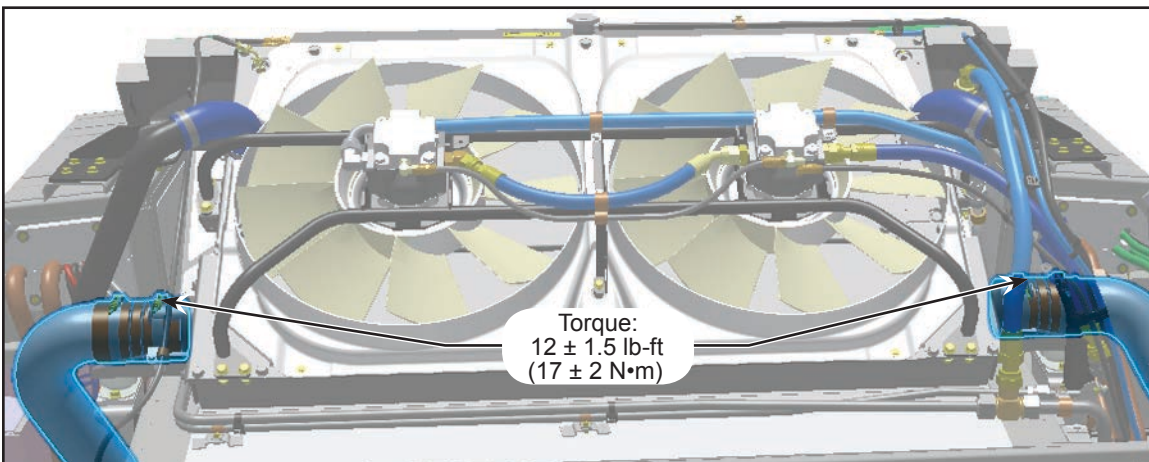

Figure 16 - Air Cooling System Lines

- 1.54. Fill of the system affected by the removal of the radiator as indicated in section 09-302 : **ENGINE COOLING, T-DRIVE** and 09-304 **HYDRAULIC SYSTEM, T-DRIVE** of the Nova Bus LFS maintenance manual.
- 1.55. Check all connections for any potential leaks. Repair if necessary.
- 1.56. Open the stop valve of the engine and heating system.

**WARNING**

Failure to repair any leaking component of the cooling system, such as a pump, valve, tube or the motor could result in a fire.

- 1.57. Close the engine door.
- 1.58. Install the radiator access door using the retained hardware. See Figure 1. ❖