

VOLUNTARY CAMPAIGN BULLETIN

SUBJECT:	Diesel Particulate Regeneration (DPR) Igniter Plugs
DATE:	03/01/2013
BULLETIN NO:	RCB-001-13
CAMPAIGN NO:	A8560
AFFECTED MODELS:	Certain 2011 through 2013 model year NE8J, NJ8J, NV8J models equipped with a J08 engine.

IMPORTANT: Verify on the Hino DCS Warranty System that the vehicle needs to have this work performed.

CONDITION:

When soot accumulates on the igniter surface, the burner ignition may perform improperly, which may cause the MIL (Malfunction Indicator Lamp) in the instrument cluster of the vehicle to turn "ON". To promote improved ignition during high soot conditions, the gap between igniter plugs was reduced. This was achieved through the inspection and/or replacement of the igniter plugs

SUBJECT VEHICLES:

Certain 2011 through 2013 model year NE8J, NJ8J, NV8J Conventional Hino Trucks equipped with a J08 engine series and assembled at the Williamstown, WV assembly plant.

BEFORE YOU BEGIN:

Read and understand all instructions and procedures before you begin. Read and observe all Notes, Cautions and Warning safety alerts that precede these instructions while following these procedures. The alerts help to avoid damage to components, serious personal injury, or both.

!!! WARNING !!!

- Park the vehicle on a level and solid surface
- Place the gear shift lever in "Neutral" or "Park" and apply the parking brake.
- Confirm the engine is stopped, the starter switch is in the off (LOCK) position, and the key is removed.
- Wear safety glasses to prevent eye injuries.
- Place wheel chocks in front of and behind all wheels.
- Prior to performing this campaign, allow the engine and exhaust to cool down to prevent any accidental burns.
- Wear insulating gloves to avoid electric shock when the battery cable is disconnected.

VOLUNTARY CAMPAIGN BULLETIN

Once Recall Is Completed

Complete a recall sticker and affix to the left door jam above the V.I.N. decal.

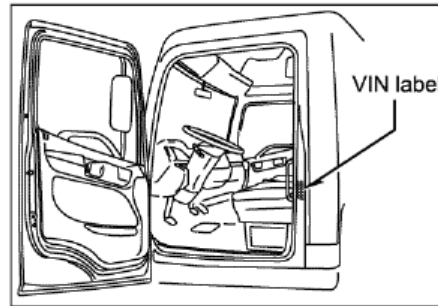

PARTS:

PART NUMBER	DESCRIPTION	QUANTITY
19200E0030	Blue Ceramic Igniter Plug	2
52030	Silkon 1000 Dielectric Grease	1
23631E0010	Nozzle Washer	1

REQUIRED SPECIAL TOOL:

SPECIAL SERVICE TOOL (SST) NUMBER	DESCRIPTION
US09992001	Igniter Plug Feeler Gauge

VEHICLE PREPARATION:

1. Park the vehicle on level ground.

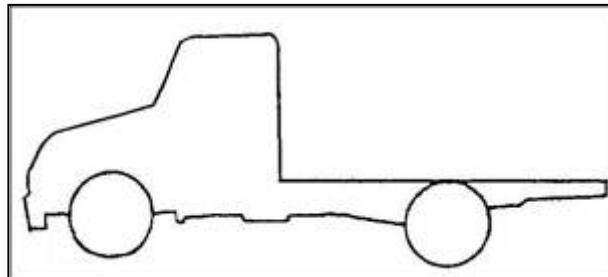

2. Confirm the engine is stopped, the ignition switch is in the off (LOCK) position, and the key is removed.



VOLUNTARY CAMPAIGN BULLETIN

3. Apply the parking brake.



4. Chock all of the wheels.

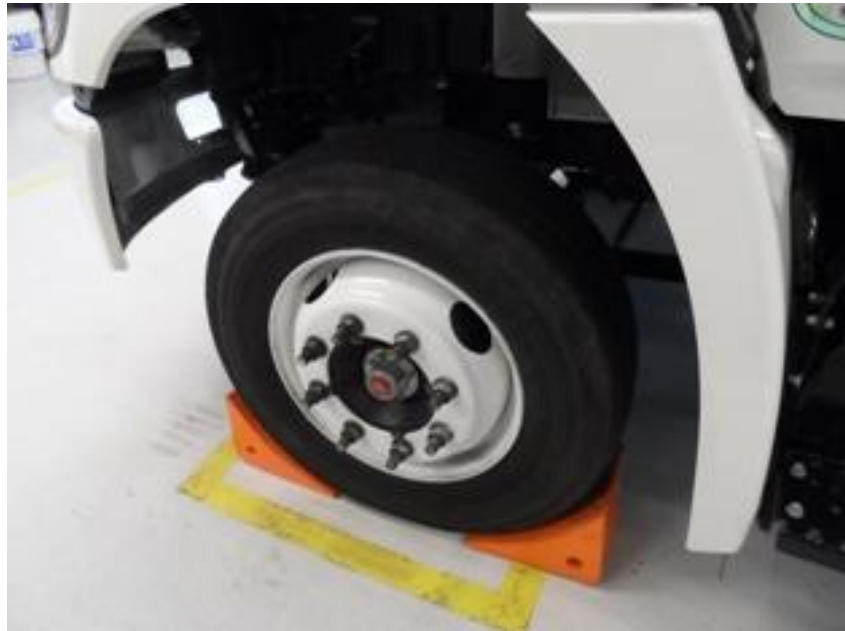

VOLUNTARY CAMPAIGN BULLETIN

REPAIR PROCEDURE:

1. Disconnect the negative battery terminal.

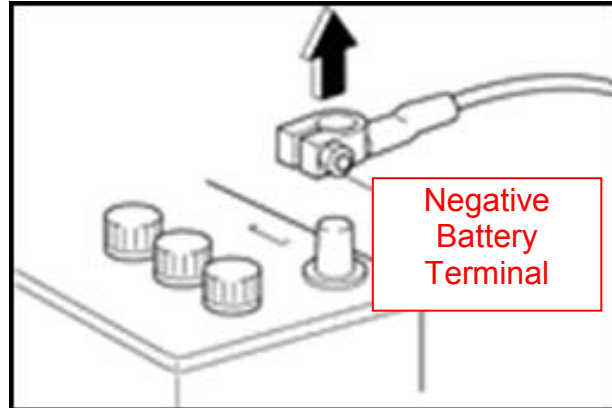

2. Removing the right inner fender.

Make certain the A/C drain hose is removed, located on the engine side of the right fender.



Remove one (1) nut and six (6) bolts (shown in the illustration to the right) that secure the right front fender. Remove the right front fender from the vehicle.

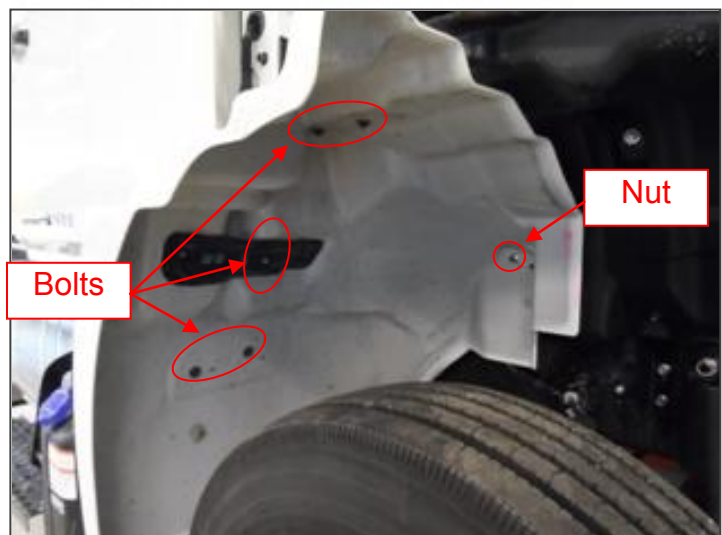

VOLUNTARY CAMPAIGN BULLETIN

3. Locate the forward face of the combustor and disconnect the ignition wires from both ceramic igniter plugs.



NOTICE

When disconnecting the ignition wires, securely grasp the center of the ignition wire boot to prevent shifting of the electrical terminal and wire position within the boot.

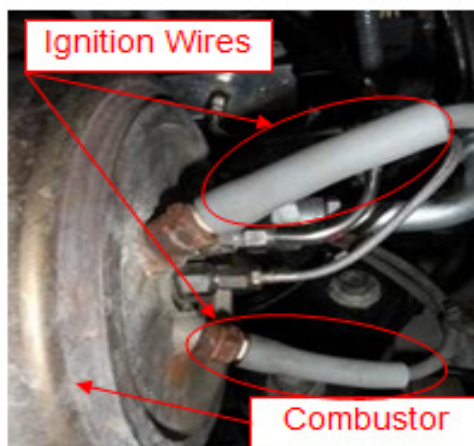

Verify the ceramic color of the igniter plugs:

- If White – go to Step 4.
- If Blue – go to Step 6.

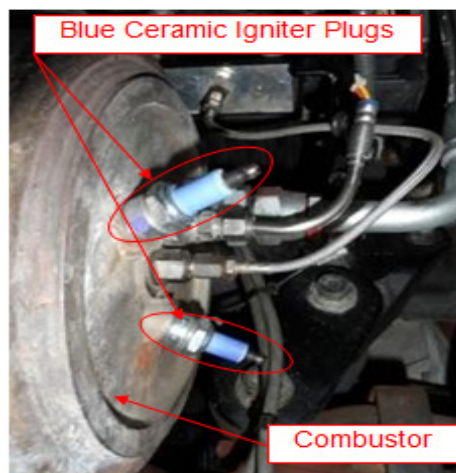
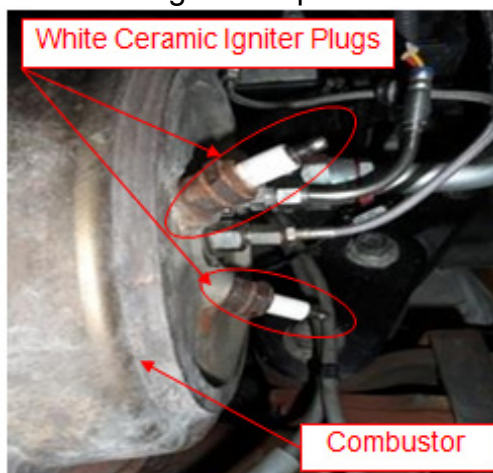

VOLUNTARY CAMPAIGN BULLETIN

4. Remove both white ceramic igniter plugs from the combustor

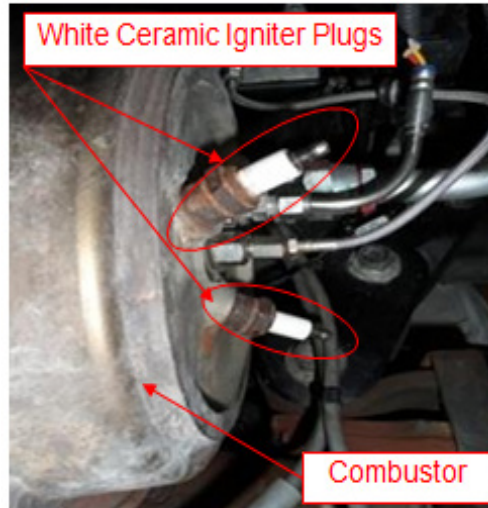

 **NOTICE**

During igniter plug removal, care should be taken to prevent any debris from entering the ignition wire boots or the combustion chamber.

 **NOTICE**

Never reuse any of the white ceramic igniter plugs removed as a result of this campaign. The specification of the white ceramic igniter plug is different from the specification of the blue ceramic igniter plug. Use of the white ceramic igniter plugs may potentially result in a burner system misfire.

5. Install two (2) new blue ceramic igniter plugs into the combustor and torque to the specified torque.

Specified Torque: 22.0 lb-ft (29.8 Nm)

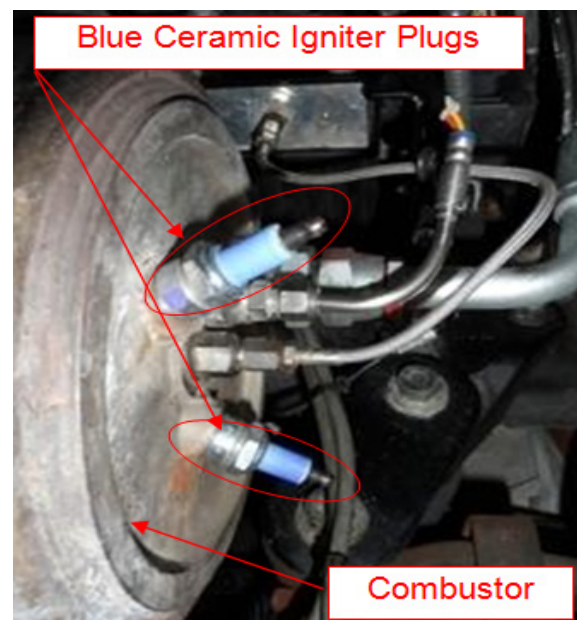

VOLUNTARY CAMPAIGN BULLETIN

6. Remove the steel braided fuel/air supply line, nozzle and copper washer. Discard the copper washer.



7. Using the SST to check igniter plug gap:

The SST is a “Go - No-Go” gauge to check the igniter gap at the tips. The tool has a 2.5mm gauge on one end and a 3.5mm gauge on the other end. The 2.5mm end should be able to pass between the igniter tips while the 3.5mm end should not.

Igniter Gap Specification: 2.5mm – 3.5mm

 **NOTICE**

Care **MUST** be taken when checking the igniter gap to make certain no damage occurs to either igniter tip or to the porcelain.

 **NOTICE**

Care **MUST** be taken to prevent any foreign debris from entering the combustor through the nozzle hole opening. If foreign debris does enter the combustor, the debris must be removed from the combustor.

VOLUNTARY CAMPAIGN BULLETIN

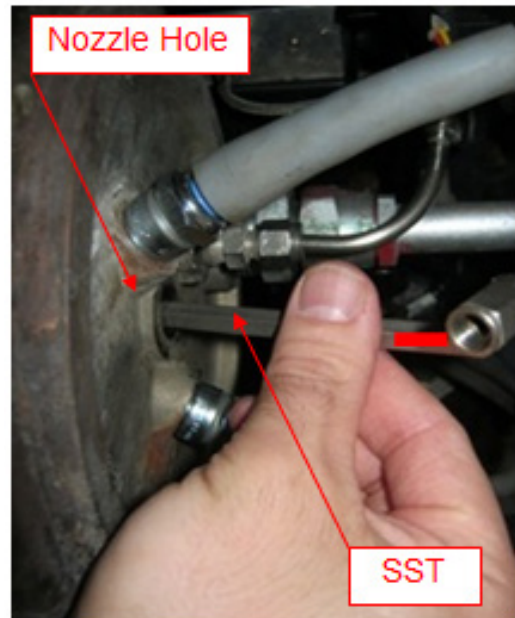
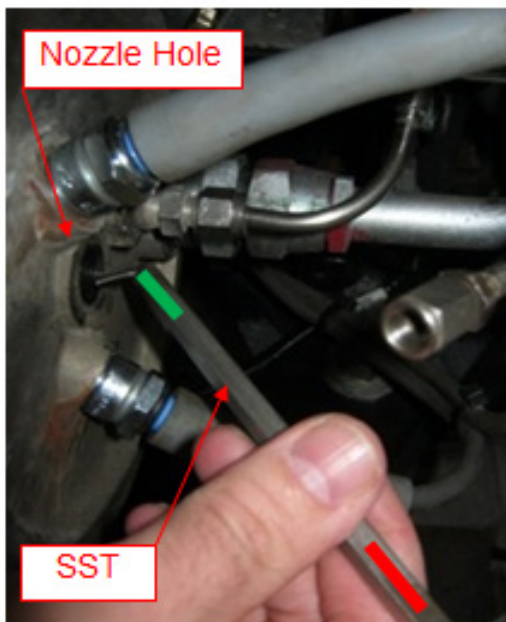
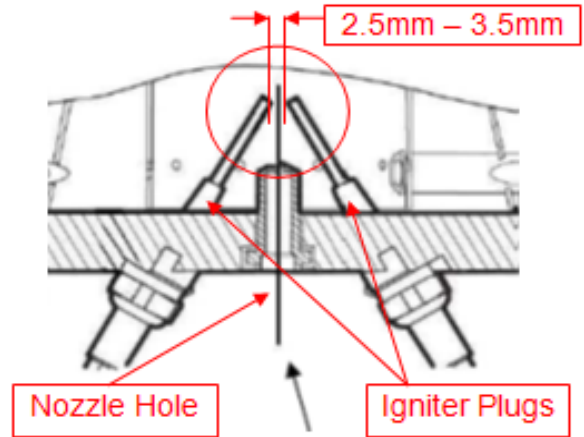
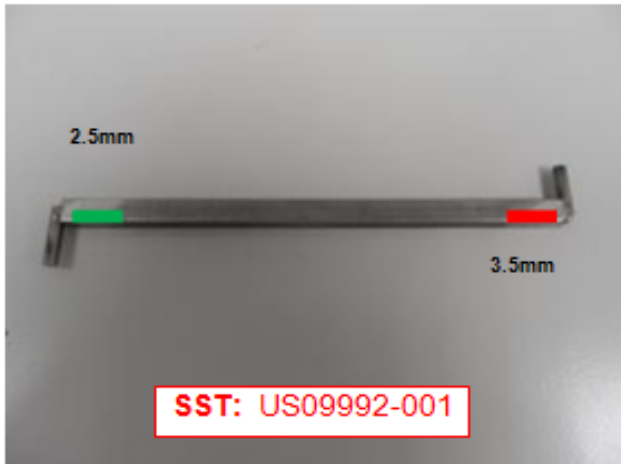

Does the igniter gap fall within the specification?

- If Yes – Go to Step 12.
- If No – Go to Step 8.

Igniter Gap Specification: 2.5mm – 3.5mm

VOLUNTARY CAMPAIGN BULLETIN

8. Remove both blue ceramic igniter plugs from the combustor.

 NOTICE
<p>During igniter plug removal, care should be taken to prevent any debris from entering the ignition wire boots or the combustion chamber.</p>

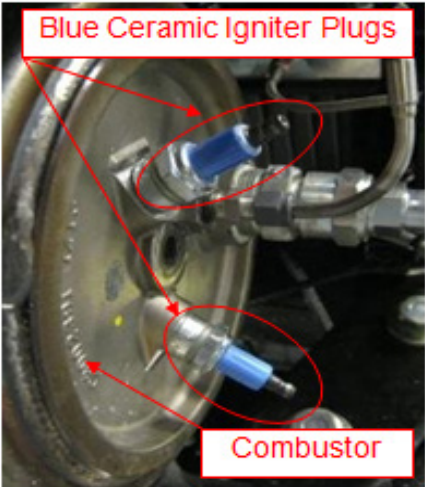

9. Switch igniter positions side to side. Reinstall both igniter plugs and torque to the specified torque.

Specified Torque: 22.0 lb-ft (29.8 Nm)

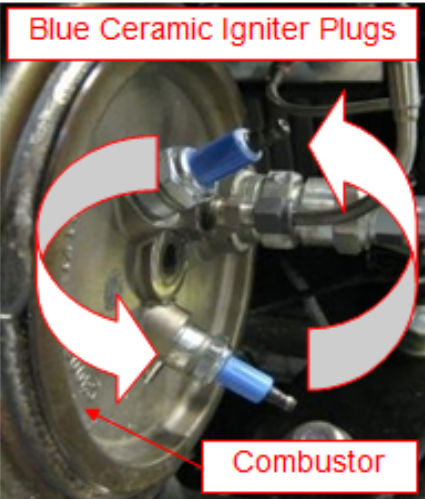

10. Using the SST, does the igniter gap fall within the specification?

- If Yes – Go to Step 12.
- If No – Go to Step 11.

11. Remove one (1) igniter from the combustor and exchange it with another new one. Due to manufacturing variability of igniters it may be necessary to replace one of the two igniters to bring the gap within specification.

Install the replacement igniter plug into the combustor then torque to the specified torque. Confirm the igniter gap meets the specification then got to Step 12. Retain the removed igniter plug for use in another vehicle.

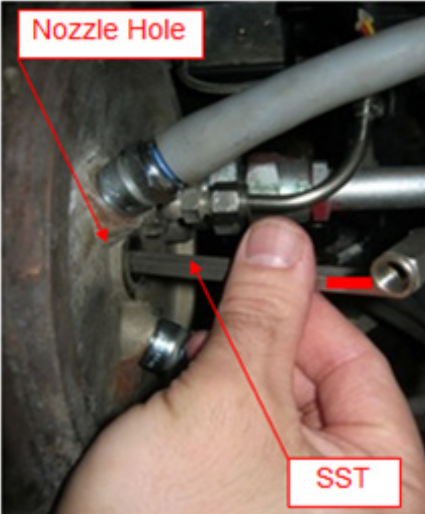

VOLUNTARY CAMPAIGN BULLETIN

12. Apply a small amount of Silkon 1000 dielectric grease on each blue ceramic igniter plug terminal.

 **NOTICE**

Do not forget to apply the Silkon 1000 dielectric grease to the igniter plug terminal. Failure to apply Silkon 1000 dielectric grease may cause electric corrosion on the igniter terminal during normal operation. Electrical corrosion on the igniter terminal may result in a burner system misfire.

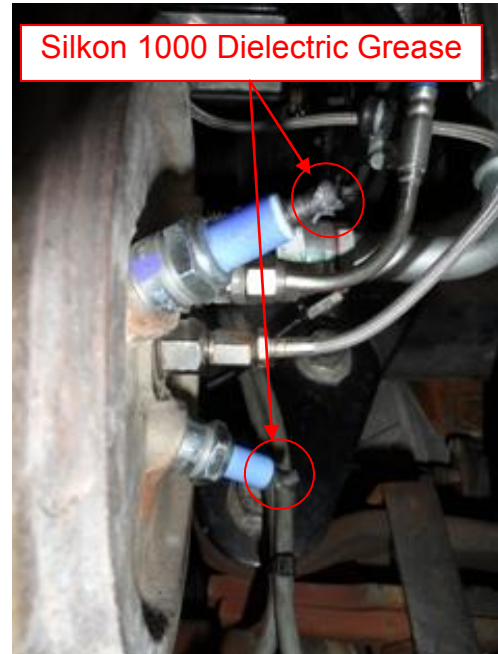

13. Install and electrically connect each ignition wire onto the corresponding blue ceramic igniter plug.



VOLUNTARY CAMPAIGN BULLETIN

14. Check the exposed ceramic surface of each igniter plug. If not within the installed specification, adjust the ignition wire boot to meet the installed specification.

Installed Specification: 0.28 inch (7mm) or less

 **NOTICE**

Failure to install the ignition wire boot to meet the installed specification may result in a burner system misfire.

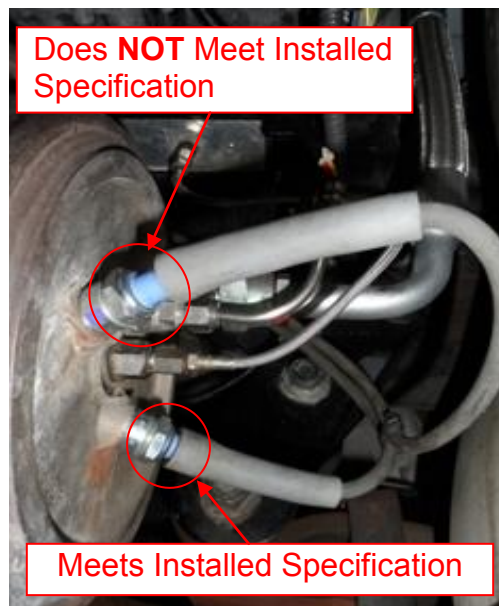
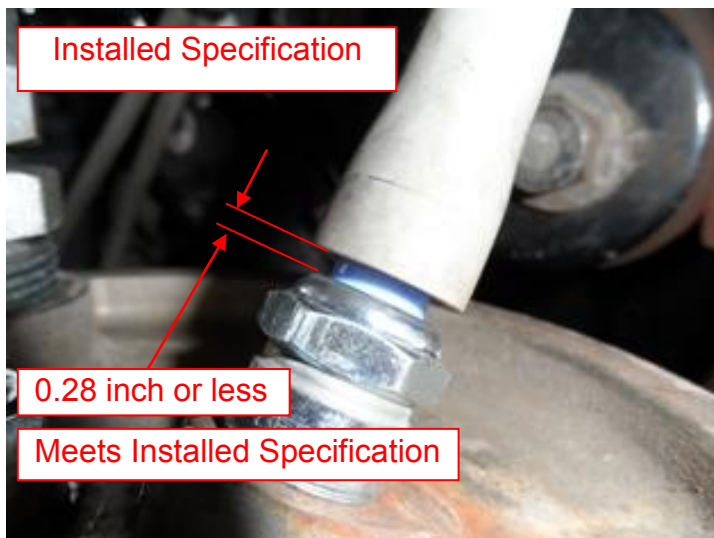

15. Using a new copper washer, install the nozzle and tighten to the specified torque.

Specified Torque: 19.9 lb-ft (27.1 Nm)

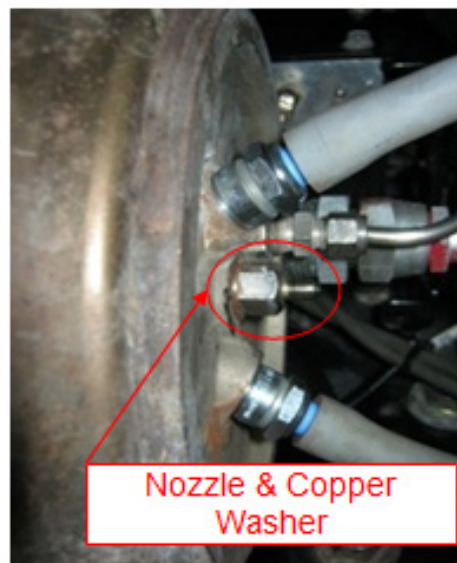

VOLUNTARY CAMPAIGN BULLETIN

16. Connect the steel braided fuel/air supply line fitting at the nozzle and tighten to the specified torque.

Specified Torque: 8.3 lb-ft (11.3 Nm)

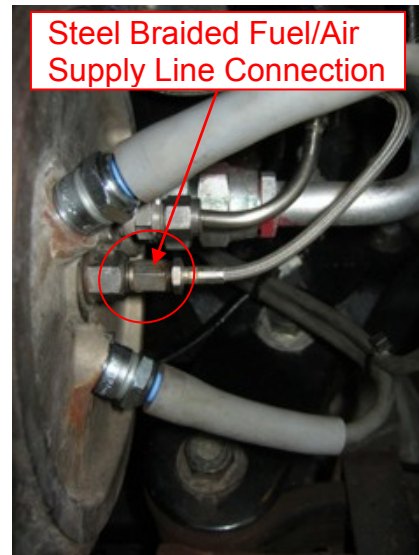

17. Install the right front fender and secure using one (1) nut and six (6) bolts (shown in the illustration to the right). Tighten each fastener to the specified torque value.

Specified Torque:

Nut: 9.6 lb-ft (13.0 Nm)

Bolt: 10.4 lb-ft (14.0 Nm)

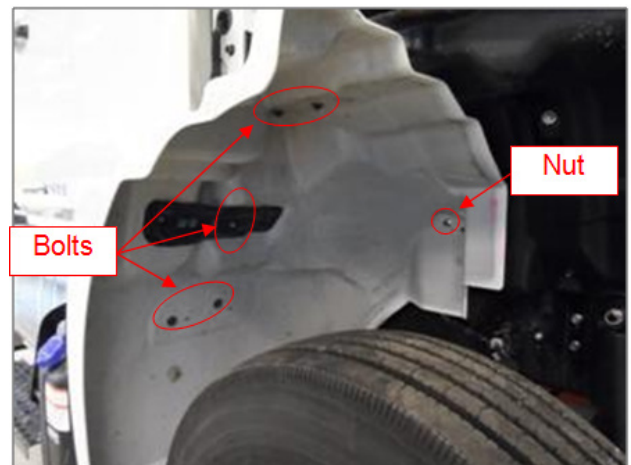

18. Make certain the A/C drain hose is secured by the clamp located on the engine side of the right fender.

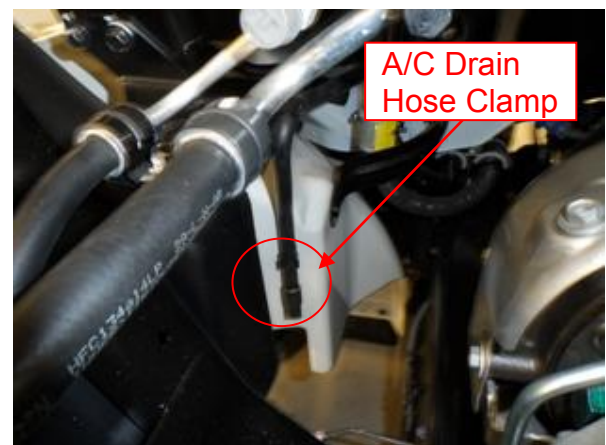

VOLUNTARY CAMPAIGN BULLETIN

19. Connect the negative battery cable and proceed to the final inspection procedure.

FINAL INSPECTION PROCEDURE:

Upon completion of the campaign procedure, review the campaign work instructions and confirm the following were performed:

1. Confirm the igniter plugs were correctly tightened to the specified torque.
2. Confirm the igniter plug gap is between 2.5mm and 3.5mm.
3. Confirm the ignition wires were correctly installed and the ignition wire boots meets the installed specification of 0.28 inch (7mm) or less.
4. Confirm there are no kinks or bends in the ignition wires.
5. Confirm the nozzle copper washer was replaced with a new washer and that the nozzle was tightened to the specified torque.
6. Confirm the braided fuel/air line connection is tightened to the specified torque.
7. Confirm the negative battery cable is correctly installed and secure.

CLAIM APPLICATION:

A. Igniter Plug Inspection, Gap Check & Adjust:

- a. Campaign No: A8560
- b. Labor Charge: 0.6hr
- c. Warranty Code: 11567 98
- d. Operation Code: 11550AOT
- e. Original Failed Part: 19200E0010

B. Igniter Plug Inspection, Igniter Plug Replacement (2 Igniter Plugs), Gap Check & Adjust:

- a. Campaign No: A8560
- b. Labor Charge: 0.8hr
- c. Warranty Code: 11567 98
- d. Operation Code: 11550AOT
- e. Original Failed Part: 19200E0010