



# Service Bulletin



## SERVICE UPDATE

**SUBJECT:** Service Update for Inventory Vehicles Only  
Transmission Snap Ring Misalignment  
Expires September 30, 2014

**MODELS:** 2013 Buick Regal, LaCrosse  
2013 Chevrolet Malibu  
Equipped with 6T40 Automatic Transmission (MHH)

Vehicles involved in this service update were placed on stop delivery August 29, 2013. Completion of the service procedure contained in this bulletin will release the vehicle from stop delivery and allow a dealer to deliver the vehicle to a customer.

An analysis of transmission build data revealed that there could be a durability issue with the transmissions originally installed in these vehicles. To ensure the highest quality and best ownership experience for our customers, these transmissions need to be replaced prior to vehicle delivery. In the interest of full disclosure, dealer must inform the customer of the transmission repair before the customer purchases the vehicle. Some states and provinces also have laws or regulations requiring disclosure. A written acknowledgement of this pre-delivery repair from the customer is strongly recommended.

### PURPOSE

This bulletin provides a service procedure to replace the transmission assembly on certain 2013 model year Buick Regal, LaCrosse and Chevrolet Malibu equipped with 6T40 automatic transmission (MHH). The transmissions in these vehicles may have been assembled with an improperly manufactured snap ring. A burr on the snap ring can cause it to stick to the aluminum housing causing the snap ring to compress and come out of the retaining groove. If this occurs, the Check Engine Light illuminates and the transmission enters default mode (Second Gear - 65 mph or 104 km/h maximum and Reverse Gear operation only). Customer complaints may include no shift, erratic shifts, growls and slipping, hesitation and jerks.

**This service procedure should be completed on involved vehicles currently in dealership inventory as soon as possible but no later than September 30, 2014, at which time this bulletin will expire.**

#### VEHICLES INVOLVED

All involved vehicles are identified by VIN in the Global Warranty Management System – Investigate Vehicle History Application. Dealership technicians should always check this site to confirm vehicle involvement prior to beginning any required inspections and/or repairs. It is important to routinely use this tool to verify eligibility because not all similar vehicles may be involved regardless of description or option content.

Additionally, a list of involved vehicles currently in dealer inventory is available on the “Service Update Bulletin Information” link under the “Service” tab in GM GlobalConnect (US) or attached to the GlobalConnect message (Canada) used to release this bulletin.

#### PART INFORMATION

Replacement transmissions will be shipped directly to dealers at no charge from the involved transmission assembly plant. Dealers should call the GM Product Quality Center (PQC) at 1-866-654-7654 to order a replacement transmission. Dealers must reference “SUB 13282” to initiate the ordering process. **Do not order from General Motors Customer Care and Aftersales (GMCCA).**

Additional parts required to complete this service update are to be obtained from GMCCA. Please refer to your “involved vehicles listing” before ordering parts. Normal orders should be placed on a DRO = Daily Replenishment Order. In an emergency situation, parts should be ordered on a CSO = Customer Special Order.

<b>Part Number</b>	<b>Description</b>	<b>Quantity/Vehicle</b>
88861037 - US	DEXRON®-VI Automatic Transmission Fluid	9
19264718 - CA	DEXRON®-VI Automatic Transmission Fluid	2

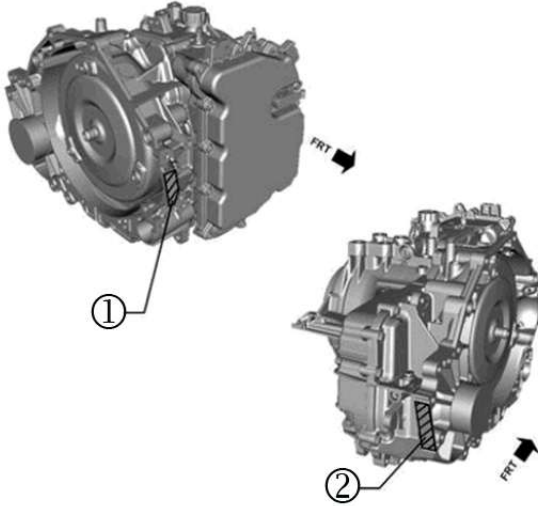
SERVICE PROCEDURE

3613040

**Note:** A VIN derivative is required to be permanently engraved on the new transmission prior to installation. Refer to the illustration above for VIN engraving location points. Select one of the locations to engrave the required characters. VIN derivatives must be formatted as indicated below (# = last eight characters of the VIN).

Buick Regal and LaCrosse: 1J\*4#####B

Chevrolet Malibu: 1J\*1#####B

Dealers will be allowed to purchase one engraving tool and attachment as described below.

Name: Dremel Engraver Tool

Manufacturer: Dremel

Model: DRE29001, or equivalent

Attachment: Diamond Point #9929

1. Remove the transmission from the vehicle. Refer to *Transmission Replacement* in SI.
2. Install a new transmission in the vehicle. Refer to *Transmission Replacement* in SI.

**WARRANTY TRANSACTION INFORMATION**

Submit a transaction using the table below. All transactions should be submitted as a ZFAT transaction type, unless noted otherwise.

<b>Labor Code</b>	<b>Description</b>	<b>Labor Time</b>	<b>Net Item</b>
9100146	Transmission Replacement	10.7	\$400.00*
Cost of Engraving Tool and Attachment (Only One Per Dealership Allowed)			**

- \* Transmission exchange allowance. Dealer must provide all required information including the Transmission Unit Number (TUN) of the new transmission.
- \*\* Submit the actual cost of the engraving tool and attachment, not to exceed \$50.00.

**DEALER PROGRAM RESPONSIBILITY**

Dealers must take the steps necessary to ensure that the service update correction has been made to all involved vehicles in dealer inventory before selling or dealer-trading the vehicle, but no later than September 30, 2014.



GM CUSTOMER CARE AND AFTERSALES  
DCS3039  
URGENT - DISTRIBUTE IMMEDIATELY

Date: September 6, 2013

Subject: 13282 – Service Update Bulletin  
Transmission Snap Ring Misalignment  
Release From Stop Delivery

Models: 2013 Buick Regal, LaCrosse  
2013 Chevrolet Malibu  
Equipped with 6T40 Automatic Transmission (RPO MHH)

To: All Buick and Chevrolet Dealers

Attention: General Manager, Service Advisor, Service Manager, Parts and  
Service Director, Parts Manager, New Vehicle Sales Manager,  
and Warranty Administrator

**Vehicles involved in this service update were placed on stop delivery August 29, 2013. Completion of the service procedure contained in this bulletin will release the vehicle from stop delivery and allow a dealer to deliver the vehicle to a customer.**

General Motors is announcing Service Update Bulletin 13282 today. The total number of U.S. vehicles involved is 27. Please see the attached bulletin for details.

**Global Warranty Management (GWM)**

The Investigate Vehicle History (IVH) screen will be updated in GWM on September 9, 2013. A list of the involved vehicles is also attached.

**Service Update Bulletin (SUB) Information Link**

The SUB Information Link in GlobalConnect will be updated in the near future.

END OF MESSAGE

GM CUSTOMER CARE AND AFTERSALES