



Service Bulletin



SERVICE UPDATE

SUBJECT: Service Update for Inventory and Customer Vehicles
Turbo Vacuum Hose Routing - Inspect
Expires with Base Warranty

MODELS: 2014 Cadillac XTS
Equipped with 3.6L V6 Engine (LF3)

This service update includes vehicles in dealer inventory and customer vehicles that return to the dealership for any reason. This bulletin will expire at the end of the involved vehicle's New Vehicle Limited Warranty period.

PURPOSE

This bulletin provides a service procedure to inspect the routing of the turbo vacuum hoses and, if necessary, reroute the hoses and replace any that are damaged on **certain** 2014 model year Cadillac XTS vehicles that are equipped with a 3.6L V6 engine (LF3). The hose on some of these vehicles may be routed incorrectly. This could cause the turbo wastegate to remain open, reduce engine power at high throttle openings, and the illumination of a MIL light at the first instance of operation demanding turbo boost.

This service procedure should be completed as soon as possible on involved vehicles currently in dealer inventory and customer vehicles that return to the dealer for any type of service during the New Vehicle Limited Warranty coverage period.

VEHICLES INVOLVED

All involved vehicles are identified by VIN in the Global Warranty Management System – Investigate Vehicle History Application. Dealership technicians should always check this site to confirm vehicle involvement prior to beginning any required inspections and/or repairs. It is important to routinely use this tool to verify eligibility because not all similar vehicles may be involved regardless of description or option content.

Additionally, a list of involved vehicles currently in dealer inventory is available on the “Service Update Bulletin Information” link under the “Service” tab in GM GlobalConnect (US) or attached to the GlobalConnect message (Canada) used to release this bulletin. Customer vehicles that return for service, for any reason, and are still covered under the vehicle's base warranty should also be checked for vehicle eligibility.

PART INFORMATIONParts Pre-Ship Information – For US and Canada

Important: Parts required to complete this service update will be pre-shipped to involved dealers of record. This pre-shipment is scheduled to begin the week of August 26, 2013, and will be 100% of each dealer's involved vehicles. Pre-shipped parts will be charged to dealer's open parts account.

Additional parts, if required, are to be obtained from GMCC&A. Please refer to your "involved vehicles listing" before ordering parts. Normal orders should be placed on a DRO = Daily Replenishment Order. In an emergency situation, parts should be ordered on a CSO = Customer Special Order.

Part Number	Description	Quantity/Vehicle
12656521	TUBE, CHRГ AIR BYPASS VLV VAC TK	1 (if req'd)

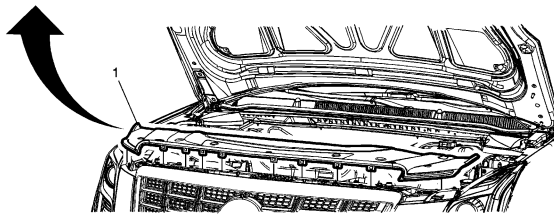
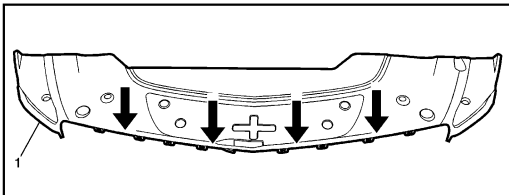
SERVICE PROCEDURE

2752274

1. Remove the front compartment front sight shield. Refer to *Front Compartment Front Sight Shield Replacement* in SI.

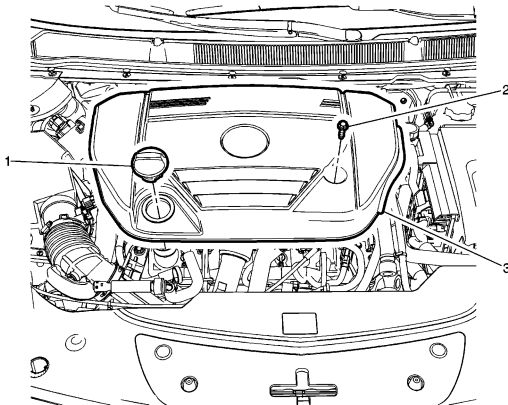

3330809

2. Remove the intake manifold cover. Refer to *Intake Manifold Cover Replacement* in SI.

Note: Inspect the turbo charger wastegate actuator vacuum boost tube bundle for proper routing. In addition, inspect the condition of the tubing and clip attachments. Ensure tubing does NOT have any kinks or cuts. Replace damaged tubing or clip attachments.

3. Determine if the turbo charger wastegate actuator vacuum boost tube bundle for the left cylinder bank is properly routed and free from kinks.

Correct Routing



3609931

- If the turbo charger wastegate actuator vacuum boost tube bundle (1) is routed correctly, no further action is required. Install the intake manifold cover and front compartment front sight shield. Refer to *Intake Manifold Cover Replacement* and *Front Compartment Front Sight Shield Replacement* in SI.

Incorrect Routing



3609947

- If the turbo charger wastegate actuator vacuum boost tube bundle (1) is NOT routed correctly, disconnect the tube bundle from the attachment points and re-route the tube bundle. Install the intake manifold cover and front compartment front sight shield AFTER completing the repair. Refer to *Intake Manifold Cover Replacement* and *Front Compartment Front Sight Shield Replacement* in SI. Refer to the following sections in this bulletin for information about how to correctly route the turbo charger wastegate actuator vacuum boost tube bundle:
 - Charge Air Bypass Valve Vacuum Tank Tube Routing and Connection Aids on Engine
 - Charge Air Bypass Valve Vacuum Tank Tube Routing and Connection Aids At Turbo Wastegate Regulator Solenoid

Charge Air Bypass Valve Vacuum Tank Tube Routing and Connection Aids on Engine

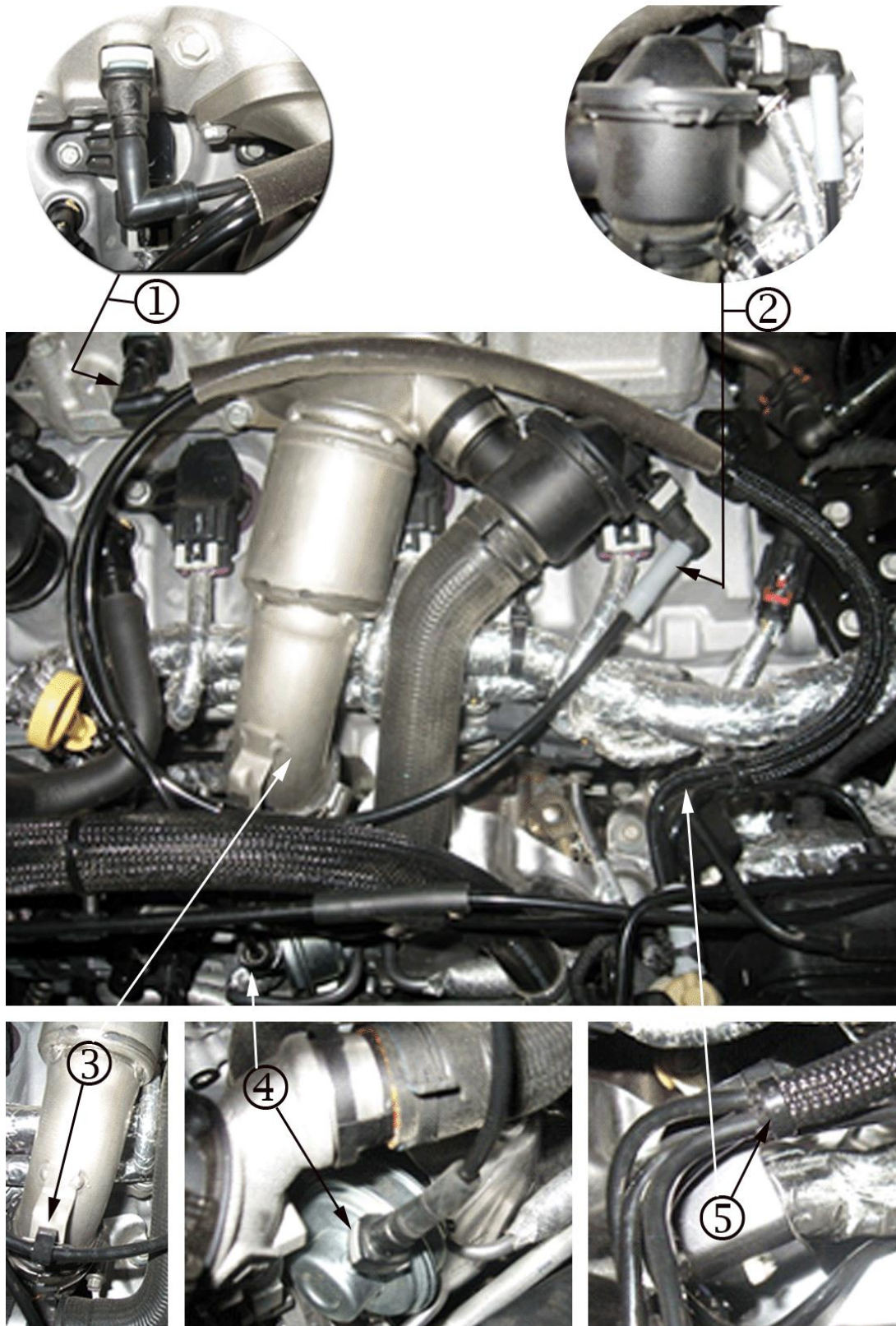

3609938

Black 90 Degree Connector (2) Gray 90 Degree Connector (3) Gray 90 Degree Connector Tube Attachment Clip Point (4) Black Straight Turbo Actuator Connection (5) Christmas Tree Fastener Attached to Bracket Hole

Charge Air Bypass Valve Vacuum Tank Tube Routing and Connection Aids At Turbo Wastegate Regulator Solenoid

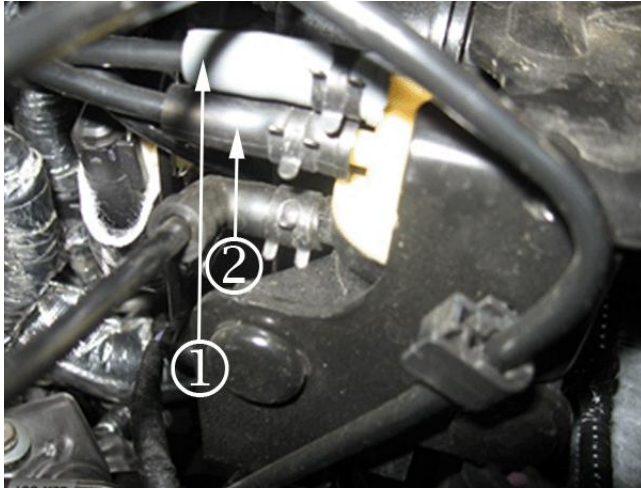

3609952

- (1) Straight Gray Tube Connection (Side View)
- (2) Straight Black tube Connection (Side View)

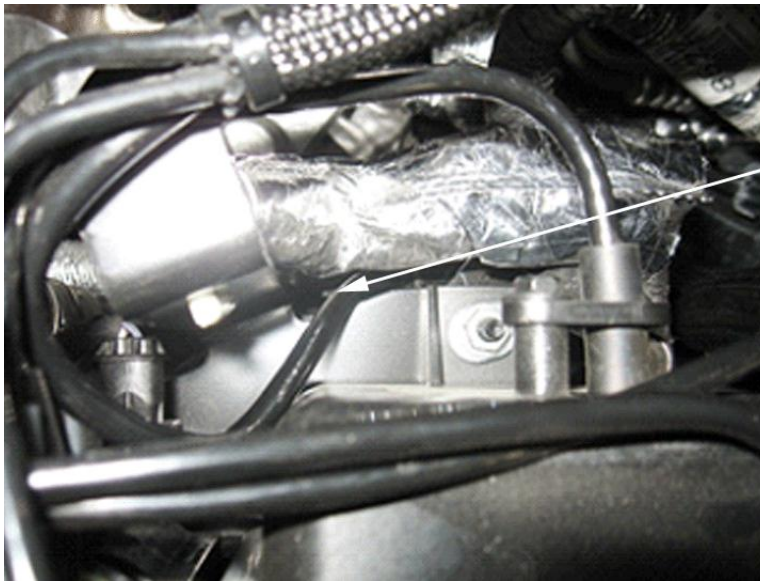

3609926

- (3) 90 Degree Black Connector Charged Air Bypass Valve Solenoid (Top View)

WARRANTY TRANSACTION INFORMATION

Submit a transaction using the table below. All transactions should be submitted as a ZFAT transaction type, unless noted otherwise.

Labor Code	Description	Labor Time
9100139	Inspect Turbo Boost Tube	0.3
	Add: Re-Route or Replace	0.2

DEALER PROGRAM RESPONSIBILITY

Whenever a vehicle subject to this service update enters your vehicle inventory, or is in your facility for service in the future, and the vehicle is still covered under the New Vehicle Limited Warranty, you must take the steps necessary to be sure the service update correction has been made before selling or releasing the vehicle.



GM CUSTOMER CARE AND AFTERSALES
DCS3034
URGENT - DISTRIBUTE IMMEDIATELY

Date: August 23, 2013

Subject: 13275 – Service Update Bulletin
Turbo Vacuum Hose Routing – Inspect

Models: 2014 Cadillac XTS Equipped with 3.6L V6 Engine (LF3)

To: All Cadillac Dealers

Attention: General Manager, Service Advisor, Service Manager, Parts and
Service Director, Parts Manager, New Vehicle Sales Manager,
and Warranty Administrator

General Motors is announcing Service Update Bulletin 13275 today. The total number of U.S. vehicles involved is 44. Please see the attached bulletin for details.

Global Warranty Management (GWM)

The “Investigate Vehicle History” (IVH) screen will be updated August 27, 2013. A list of involved VINs is attached to this message. Parts for involved vehicles will be shipped to the dealer on the list. Please hold all claims until the VIN appears in IVH.

Service Update Bulletin (SUB) Information Link

The SUB Information Link in GlobalConnect will be updated in the near future.

END OF MESSAGE

GM CUSTOMER CARE AND AFTERSALES