



# Service Bulletin



## SERVICE UPDATE

**SUBJECT:** Service Update for Inventory and Customer Vehicles  
Front Seat Cushion Trim Retention  
Expires with Base Warranty

**MODELS:** 2013 Cadillac XTS

**Step 2 of the service procedure and the illustration for Steps 3 and 7 have been revised. Please discard all copies of bulletin 12290.**

**This service update includes vehicles in dealer inventory and customer vehicles that return to the dealership for any reason. This bulletin will expire at the end of the involved vehicle's New Vehicle Limited Warranty period.**

### PURPOSE

This bulletin provides a service procedure to tighten the driver and front passenger seat cushion trim on **certain** 2013 model year Cadillac XTS vehicles. Customers may report that the trim on the front corners of the seat cushion is loose and potentially bunching or wrinkling.

**This service procedure should be completed as soon as possible on involved vehicles currently in dealer inventory and customer vehicles that return to the dealer for any type of service during the New Vehicle Limited Warranty coverage period.**

### VEHICLES INVOLVED

All involved vehicles are identified by VIN in the Global Warranty Management System – Investigate Vehicle History Application. Dealership technicians should always check this site to confirm vehicle involvement prior to beginning any required inspections and/or repairs. It is important to routinely use this tool to verify eligibility because not all similar vehicles may be involved regardless of description or option content.

Additionally, a list of involved vehicles currently in dealer inventory is available on the “Service Update Bulletin Information” link under the “Service” tab in GM GlobalConnect (US) or attached to the GlobalConnect message (Canada) used to release this bulletin. Customer vehicles that return for service, for any reason, and are still covered under the vehicle's base warranty should also be checked for vehicle eligibility.

PART INFORMATION

Parts required to complete this service update are to be obtained from General Motors Customer Care and Aftersales (GMCC&A). Please refer to your "involved vehicles listing" before ordering parts. Normal orders should be placed on a DRO = Daily Replenishment Order. In an emergency situation, parts should be ordered on a CSO = Customer Special Order.

Part Number	Description	Quantity/Vehicle
06616858	RING,HOG	2
11611745	RETAINER,D/SEAT CUSH CVR	2

SERVICE PROCEDURE

Re-secure the front corners of BOTH front seat cushion covers by adding a retaining clip to the outboard side and a hog ring to the inboard side of each seat following the steps below:

1. Position the affected seat fully rearward and the seat cushion fully upward.

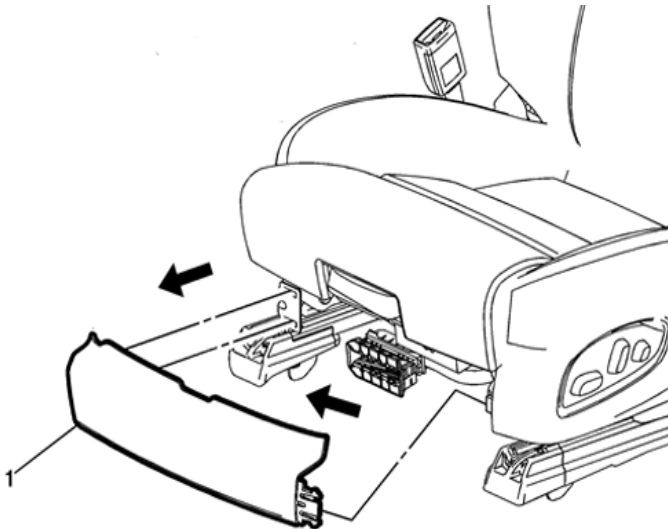

2910856

2. Remove the front seat adjuster finish cover (1). Refer to *Driver or Passenger Seat Adjuster Finish Cover Replacement* in SI. The knobs do not need to be removed because the switch(s) will remain attached to the Adjuster Finish Cover. After removing the screw, the Adjuster Finish Cover must be gently pulled upwards to release the hook features. Use care to avoid pulling on electrical wiring prior to disconnecting the switch(s). Once the switch(s) on the Seat Adjuster Finish Cover is disconnected, the cover can be removed to allow access to the seat cushion cover for repair.

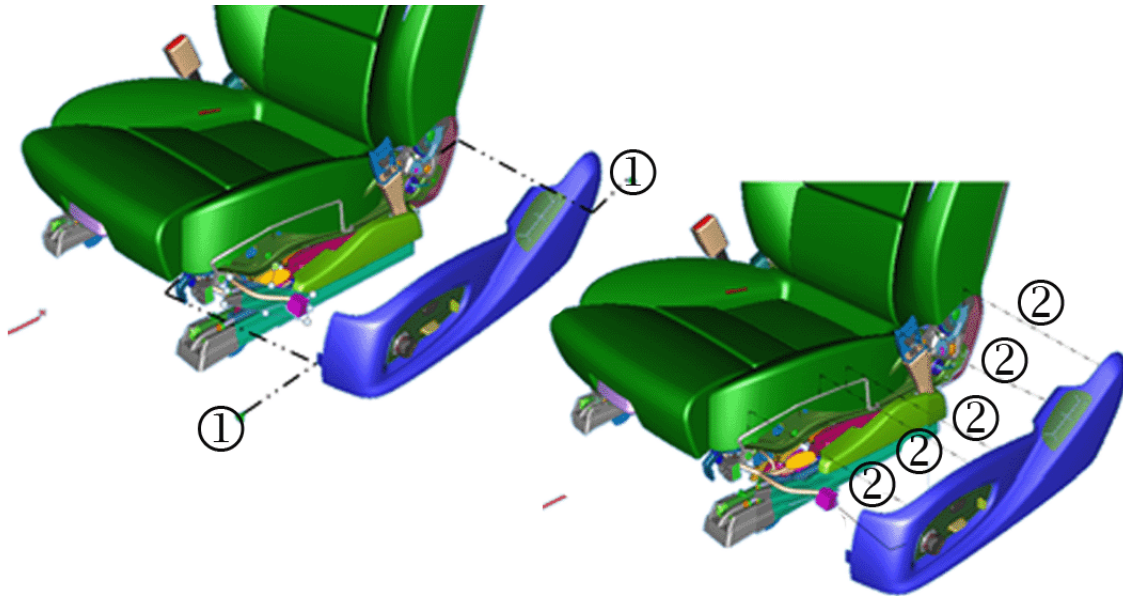

3350732

3. Starting the outboard side repair, remove the front screw (1) retaining the seat cushion outer finish panel (2) and detach the front half of the panel from the seat frame.



2965479

Note: Some seats may have a single hog ring (1) at either or both front corners of the seat.

- For the outboard corner repair, it will be necessary to remove this hog ring to fully release the J-channel from the seat frame.
- For the inboard corner repair, leave the existing hog ring intact.

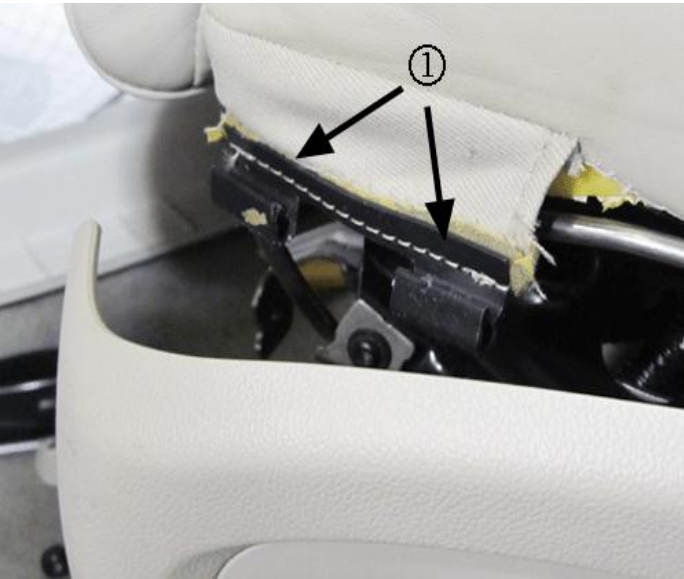

2910863

4. Fully release the outboard front corner seat cushion cover J-channel (1) from the seat frame.
5. Add a retaining clip to the outboard front corner of the seat, completing the following steps:



2965480

- 5.1. Fold the J-channel back under the cover fabric material, but do not attach to the frame. Note the location of the bottom edge of the channel through the material.



2965482

- 5.2. Using a utility knife or similar tool, cut a slit in the material fabric along the bottom edge of the J-channel, about half the width of the channel.
- 5.3. Reinstall the J-channel to the front corner of the seat frame.

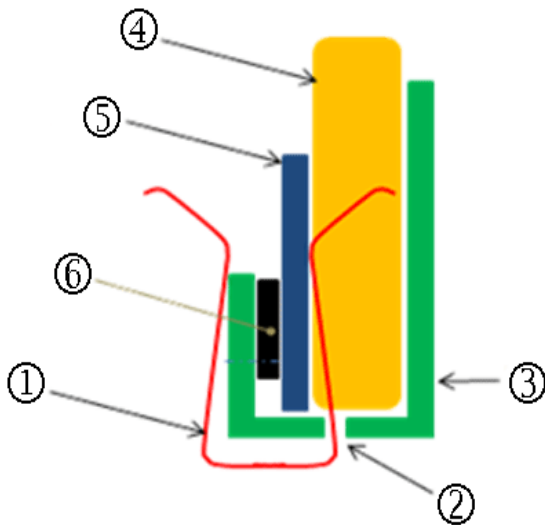

2965484

Note: A cross section of the clip installation is shown in the illustration above. Ensure the clip (1) is inserted through the slit (2) in the seat material (3), between the foam (4) and the seat frame (5), capturing the material and J-channel (6).



- 5.4. Install one of the seat cushion cover retainers (1) to the seat, pushing one leg through the slit in the fabric and the other over the seat frame, capturing the J-channel against the frame.

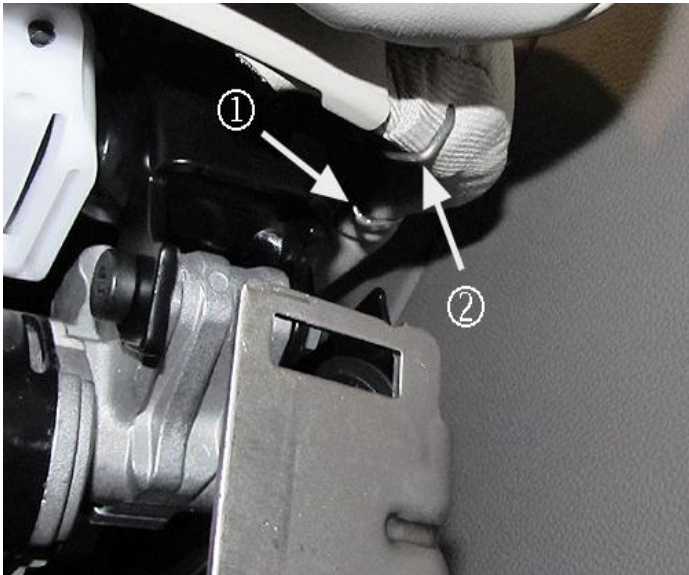

**Note:** The graphic above shows the original (1) and the added hog ring (2) on the passenger front seat.

6. Add a hog ring, or equivalent, to the inboard front corner of the cushion cover and J-channel. Snap the hog ring around the front end of the J-channel and the seat frame as shown in the graphic above.



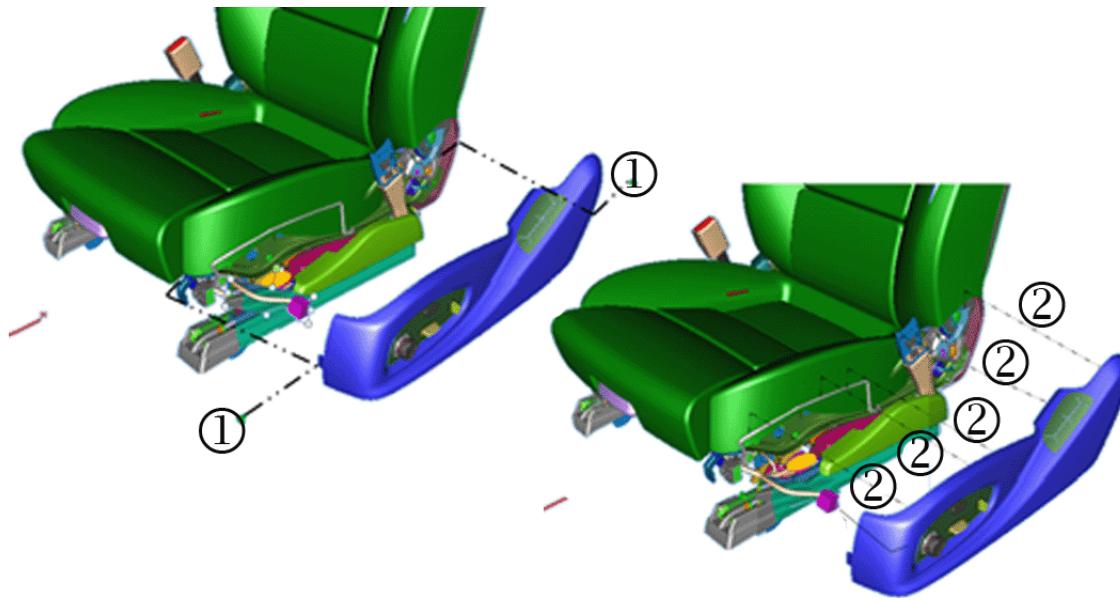

3350732

7. Reposition the outer finish panel (2) to the seat frame and install the front retaining screw (1).

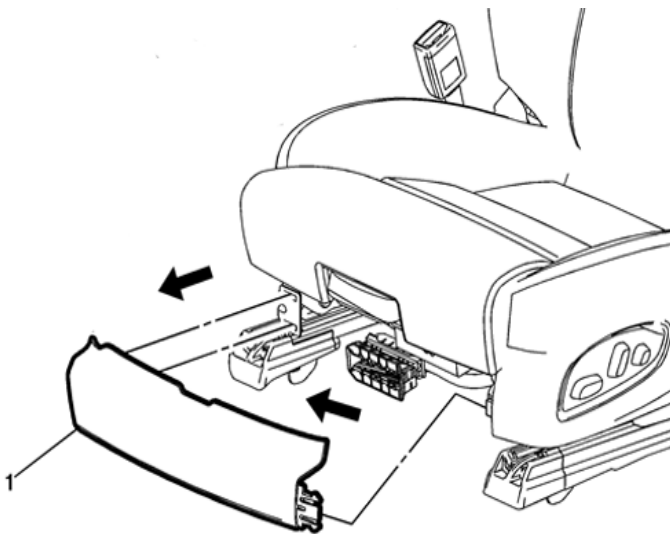

2910856

8. Reinstall the front seat adjuster finish cover. Refer to *Driver or Passenger Seat Adjuster Finish Cover Replacement* in SI.



2910874

9. Verify proper retention and appearance of the seat cushion cover as shown above.
10. Repeat Steps 1-9 on the opposite side front seat.

#### WARRANTY TRANSACTION INFORMATION

Submit a transaction using the table below.

Labor Code	Description	Labor Time
V2713	Add Clips/Hog Rings to Driver and Passenger Front Seat Cushion Covers	0.8

#### DEALER PROGRAM RESPONSIBILITY

Whenever a vehicle subject to this service update enters your vehicle inventory, or is in your facility for service in the future, and the vehicle is still covered under the New Vehicle Limited Warranty, you must take the steps necessary to be sure the service update correction has been made before selling or releasing the vehicle.



GM CUSTOMER CARE AND AFTERSALES  
DCS2931  
URGENT - DISTRIBUTE IMMEDIATELY

Date: March 19, 2013

Subject: 12290A – Service Update  
Front Seat Cushion Trim Retention  
Revised Service Procedure

Models: 2013 Cadillac XTS

To: All Cadillac Dealers

Attention: General Manager, Service Advisor, Service Manager, Parts and  
Service Director, Parts Manager, New Vehicle Sales Manager,  
and Warranty Administrator

Step 2 of the service procedure and the illustration for Steps 3 and 7 have been revised. Please discard all copies of bulletin 12290.

END OF MESSAGE  
GM CUSTOMER CARE AND AFTERSALES