



Service Bulletin

PRELIMINARY INFORMATION

Subject: Water Leak at Driver/Front Passenger Floor Area and/or Front Carpet Wet

Models: 2010-2013 Cadillac SRX

This PI has been revised to update the Condition/Concern, Recommendation/Instructions sections and update the Warranty Information with the Global Labor Code (GLC). Please discard PI0044C.

Condition/Concern

Some customers may comment on seeing a water leak in the driver or front passenger floor area and/or finding the front carpet wet.

The most common causes of this concern are:

- There may be a void in the cowl seam sealer, in the corners below the sunroof drain hose grommets.
- The sunroof front drain hose grommet(s) may not be connected or fully seated in the cowl panel or at the sunroof frame spigot.
- The sunroof front drain hoses are mis-routed or are too short, and display a higher level of tension. This higher tension may tend to cause a future disconnect or unseating of the grommet.

Recommendation/Instructions

Complete the following inspection procedure before doing any repairs.

Water Test Inspection Procedure

1. Park the vehicle on a level surface.
2. Fully open the sunroof window.
3. Fill an appropriate container with approximately 16 ounces (473 ml) of water.



4. Pour water into the outboard front corner of the sunroof frame on one side of the vehicle, and immediately inspect the area rearward of the front tire for water flowing out onto the floor surface.
5. Repeat steps 3 and 4 on the opposite side.

- If water is properly flowing out the front drain hoses, jump ahead to the “Seal Cowl Seam Repair Procedure” section below and complete the repair steps listed.
- If water is NOT properly flowing out the front drain hoses, first replace BOTH sunroof front drain hoses following the repair steps below, then continue ahead and complete the “Seal Cowl Seam Repair Procedure” repair steps.

Left and Right Sunroof Front Drain Hose Replacement Procedure

Note: Refer to the GM Parts Catalog for the appropriate front drain hose part numbers.



1. Starting on the left or right side, remove the windshield garnish molding from the A-pillar by pulling gently from the top to disengage the attachment clip. Detach the rubber stop (1) on the tether clip from the molding and disconnect the speaker wiring harness (2).

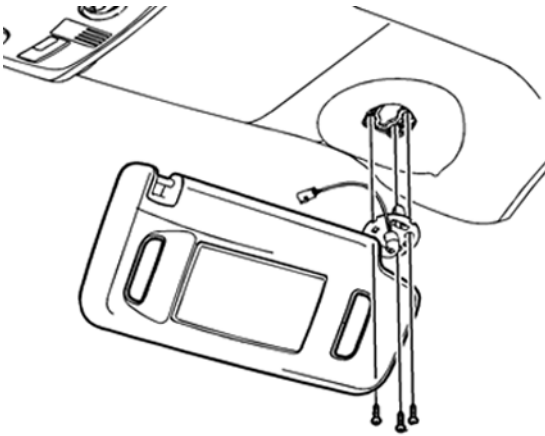

2. Remove the sunshade. Refer to Sunshade Replacement in SI.

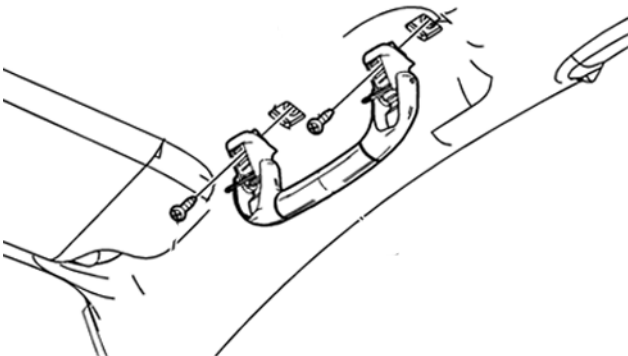

3. Remove the front assist handle. Refer to Front Assist Handle Replacement in SI.



4. Pull the front corner of the headliner downward to access the drain hose and sunroof drain spigot connection, circled above.

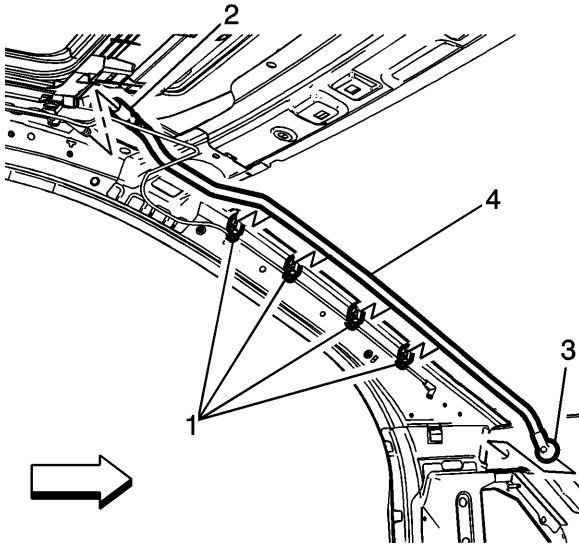

5. Disengage the sunroof drain hose from the attachment points on the windshield pillar (1).
6. Disconnect the front sunroof drain hose from the sunroof drain spigot (2).
7. Disconnect the drain hose and grommet (3) from the cowl panel.
8. Remove the drain hose (4) from the vehicle.

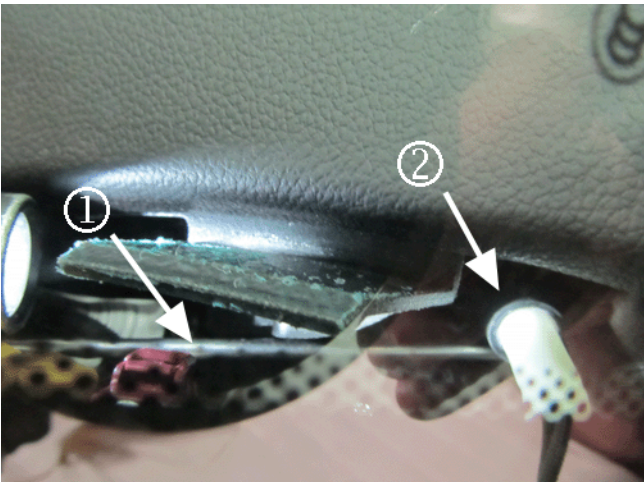

Important: Verify proper engagement of the grommet to cowl panel to prevent a water leak.

9. Using a long, thin suitable tool (1), connect the grommet end of the hose (2) to the cowl panel by pushing the grommet into its hole.

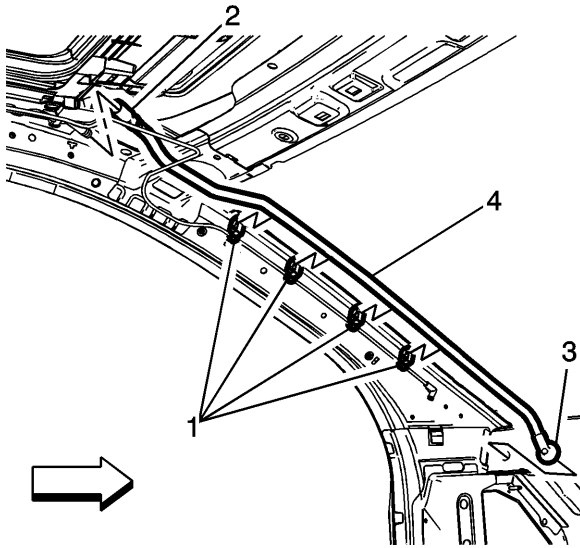

10. Connect the front sunroof drain hose to the sunroof drain spigot (2).
11. Connect the sunroof drain hose to the attachment points on the windshield pillar (1).
12. Repeat steps 1-11 on the opposite side of the vehicle.
13. Water test the vehicle before installing the headliner and trim.
14. Reposition the headliner and reinstall the left and right front assist handles. Refer to Front Assist Handle Replacement in SI.
15. Reinstall the left and right sunshades. Refer to Sunshade Replacement in SI.
16. Reattach the tether clips and reconnect the speaker wiring harness to the left and right windshield garnish moldings.
17. Ensuring the retaining tabs are fully seated, position the left and right garnish to the A-pillars and push securely in place.

Seal Cowl Seam Repair Procedure

Apply sealer to the front cowl seam following the steps below:

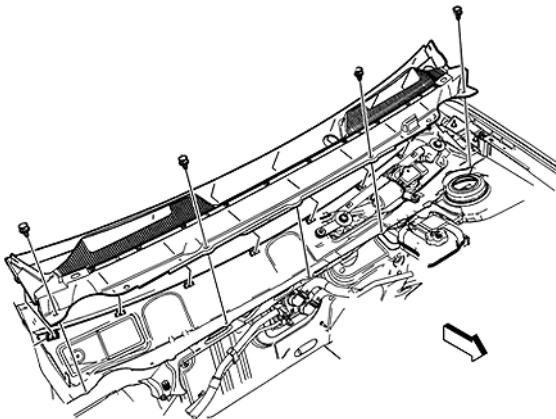

1. Remove the air inlet grille panel. Refer to Air Inlet Grille Panel Replacement in SI.

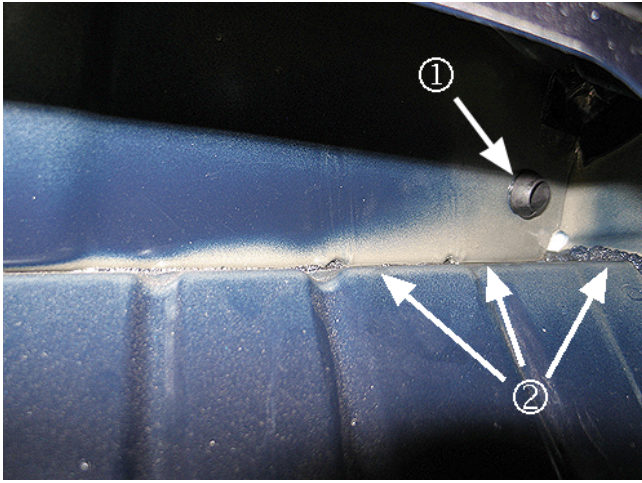

2. Inspect that the front sunroof drain hoses and grommets (1) are connected and fully seated to the cowl on both sides.
3. Water test the cowl by running water along the cowl seam (shown in the graphic above), which runs across the front of the vehicle.
4. If water drips are evident, inspect the seam for voids (2) in the sealer. Clean the affected area and seal the void with Kent High Tech™ Clear Seam Sealer, P/N P10200 (5 oz tube), or equivalent.
5. Reinstall the air inlet grille panel. Refer to Air Inlet Grille Panel Replacement in SI.

Parts Information

Contact Kent Automotive at 1-888-YES-Kent or online at www.kent-automotive.com.

Part Number	Description
P10200	Kent High Tech™ Clear

Warranty Information

For vehicles repaired under warranty, use:

Labor Operation	Description	Labor Time
6080058*	R & R Air Inlet Grille Panel – Apply Sealer to Cowl Seam	0.6 hr
Add	Replace Both Sunroof Front Drain Hoses	1.4 hrs

*This is a unique labor operation for bulletin use only. It will not be published in the Labor Time Guide.

GM bulletins are intended for use by professional technicians, NOT a "do-it-yourselfer". They are written to inform these technicians of conditions that may occur on some vehicles, or to provide information that could assist in the proper service of a vehicle. Properly trained technicians have the equipment, tools, safety instructions, and know-how to do a job properly and safely. If a condition is described, DO NOT assume that the bulletin applies to your vehicle, or that your vehicle will have that condition. See your GM dealer for information on whether your vehicle may benefit from the information.



WE SUPPORT VOLUNTARY TECHNICIAN CERTIFICATION