

© 2013 Mazda Motor of America, Inc.

Subject: CHIRP NOISE FROM RIGHT REAR AT 60 MPH OR MORE	Bulletin No: 09-001/13
	Last Issued: 11/11/2013

BULLETIN NOTE

- This bulletin supersedes the previous bulletins 09-001/13 issued 02/15/13 and 09-018/12 issued 04/20/12. The APPLICABLE MODEL(S)/VINS, DESCRIPTION, REPAIR PROCEDURE and WARRANTY INFORMATION have been revised.
- Changes are noted below in Red beside the change bar.

APPLICABLE MODEL(S)/VINS

2013-2014 CX-5 vehicles with VINs lower than JM3KE*****358081 (produced before June 3, 2013)

DESCRIPTION

While driving at approx. 60 mph or more, some vehicles may exhibit a chirp noise from rear right end of the vehicle.

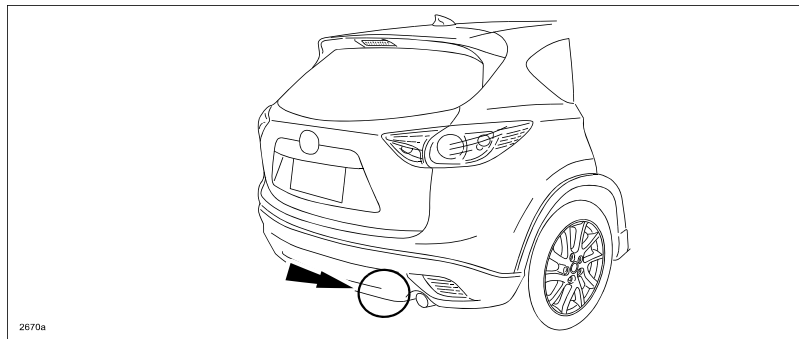

The chirp noise may be caused by the right side rear bumper stay hook (A) contacting the bumper reinforcement (B) at high speed. The shape of the reinforcement hole has been changed on both sides to eliminate the noise. Also, pads have been added to the bumper stay to prevent contact noise.

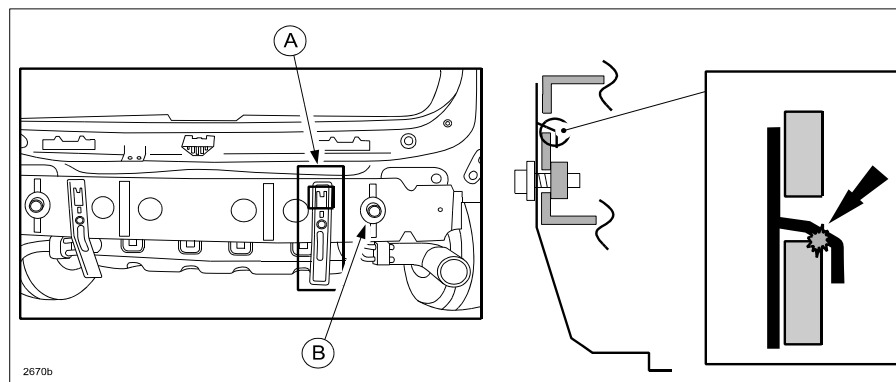

Customers having this concern should have their vehicle repaired using the following repair procedure.

Page 1 of 5

CONSUMER NOTICE: The information and instructions in this bulletin are intended for use by skilled technicians. Mazda technicians utilize the proper tools/equipment and take training to correctly and safely maintain Mazda vehicles. These instructions should not be performed by "do-it-yourselfers." Customers should not assume this bulletin applies to their vehicle or that their vehicle will develop the described concern. To determine if the information applies, customers should contact their nearest authorized Mazda dealership. Mazda North American Operations reserves the right to alter the specifications and contents of this bulletin without obligation or advance notice. All rights reserved. No part of this bulletin may be reproduced in any form or by any means, electronic or mechanical---including photocopying and recording and the use of any kind of information storage and retrieval system ---without permission in writing.

REPAIR PROCEDURE

1. Verify the customer concern by lightly tapping the left and right sides of the rear bumper by hand.
 - If the noise is heard on either side, follow the repair procedure below to eliminate the concern.
 - If the noise is not heard on either side, this service bulletin is not applicable.
2. Remove the rear bumper from the vehicle according to the instructions on MS3 online or the Workshop Manual (section 09-10 REAR BUMPER REMOVAL/INSTALLATION).
3. Confirm the chirp noise again by hitting the lower side of left and right bumper stays by hand.

NOTE: Even if there is no chirp noise on the left side, perform the repair on both sides.

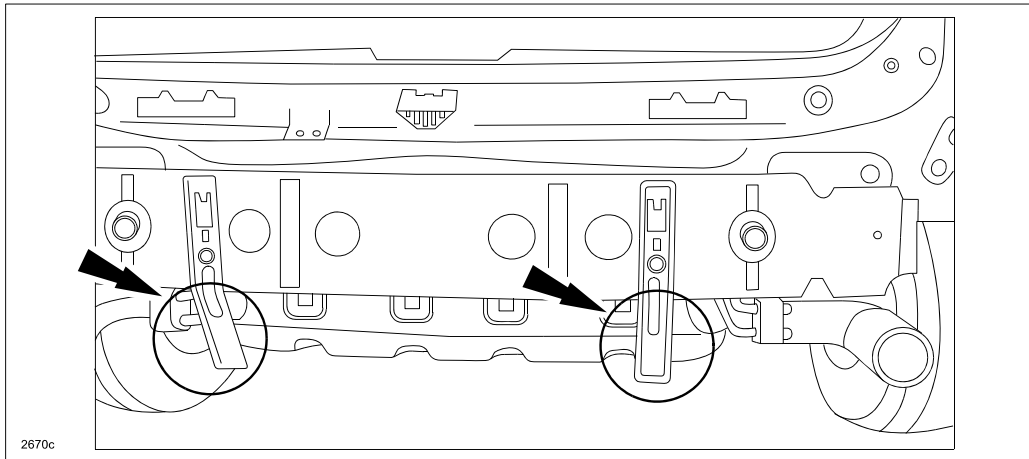

4. Remove the bumper stay mounting bolts on both sides, then remove the bumper stays.

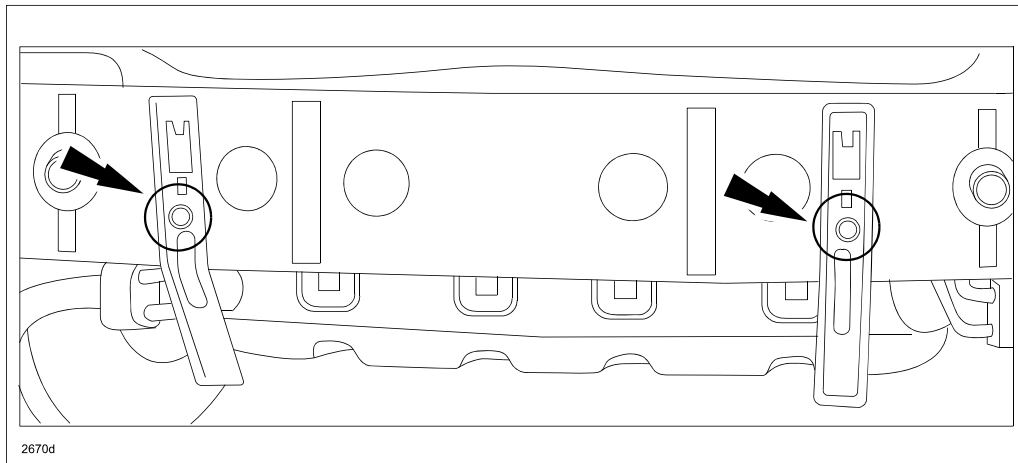

5. Depending on the VIN and vehicle production date, following the steps below:
 - For vehicles produced on Feb. 29, 2012 or before, complete Steps 6 ~ 14.
 - For vehicles produced **between Mar. 1, 2012 and June 3, 2013**, skip Steps 6 ~ 7, complete Steps 8 ~ 14

VIN	Serial Number	Production Date	Repair Procedure Steps
JM3KE*****	000001 ~ 111092	on or before Feb. 29, 2012	Complete Steps 6 ~ 14
JM3KE*****	111093 ~ 358080	between Mar. 1, 2012 and June 3, 2013	Complete Steps 8 ~ 14

6. File off the inside of both lower hole corners (A) as shown below.

NOTE:

- File off the shaded area until there is no contact between the bumper stay hook and bumper reinforcement.
- Clean the area with an air hose.

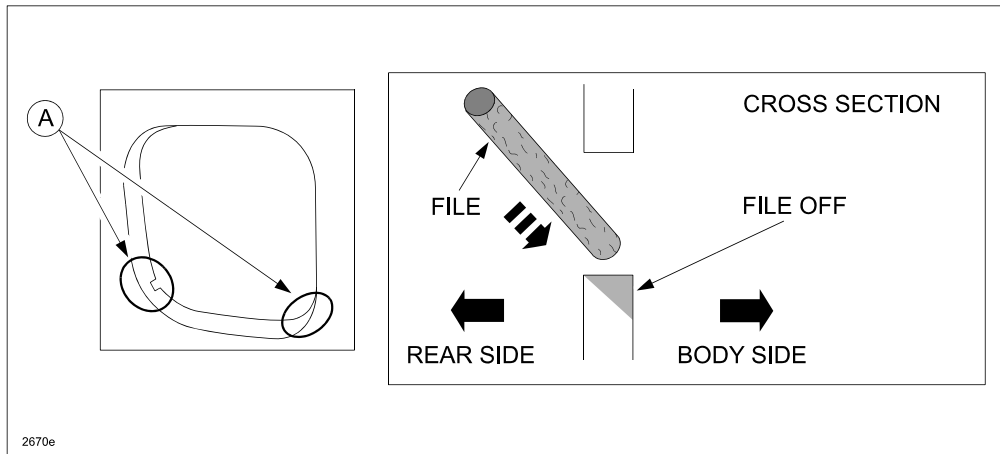

7. After cleaning the filed areas, apply touch-up paint to prevent rust.

8. Select a 0.25mm thickness sheet from the "Noise Repair Kit". Cut the sheet into the (6) six following size pieces:

- 4 pieces - 20 x 20mm
- 2 pieces - 20 x 10mm

9. Apply (1) one 20 x 20mm pad (B) along the upper edge of the bumper reinforcement, above the hole for hook (A). Repeat Step 9 on the opposite side of vehicle.

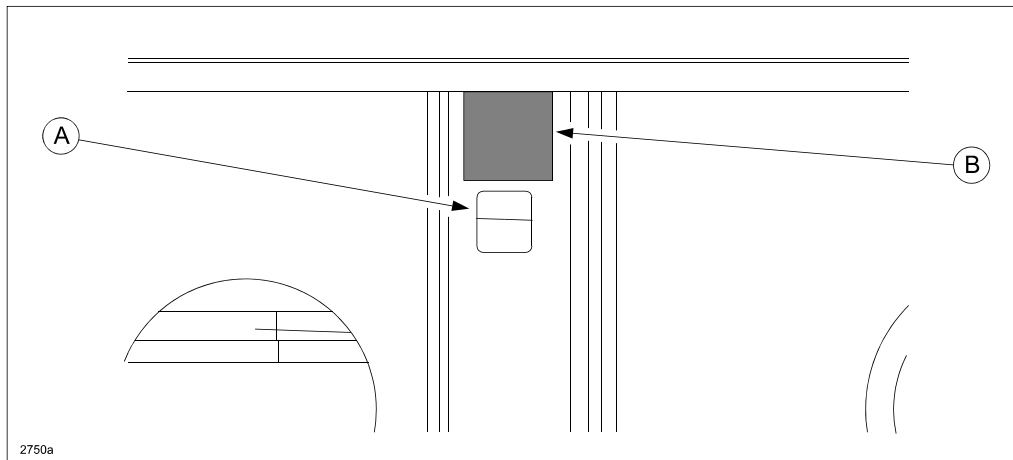

10. (a) Apply (2) two 20 x 20mm pads (C) on the front side of each bumper reinforcement (A), at the upper part of the bumper stay (B).

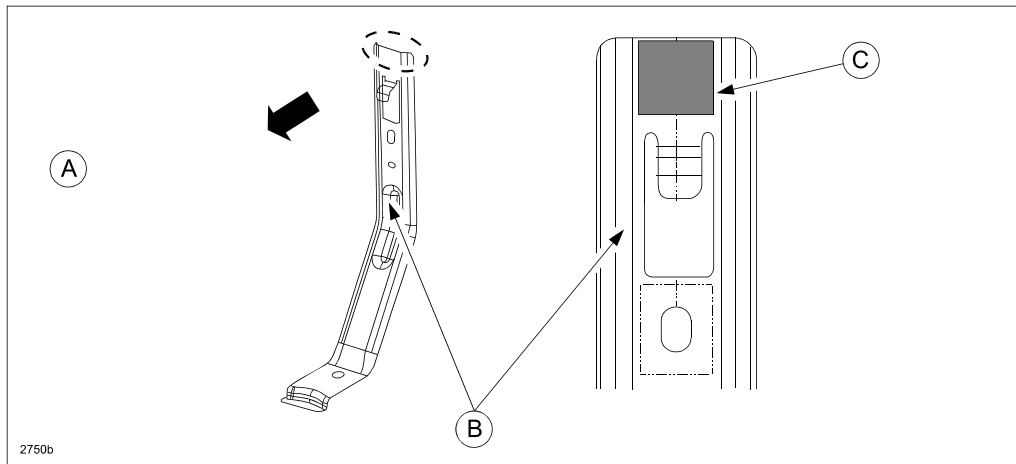

- (b) Apply (2) two 20 x 10mm pads (A) on the hook (B) of bumper stay. Wrap the pad (C) around both edges of the hook.

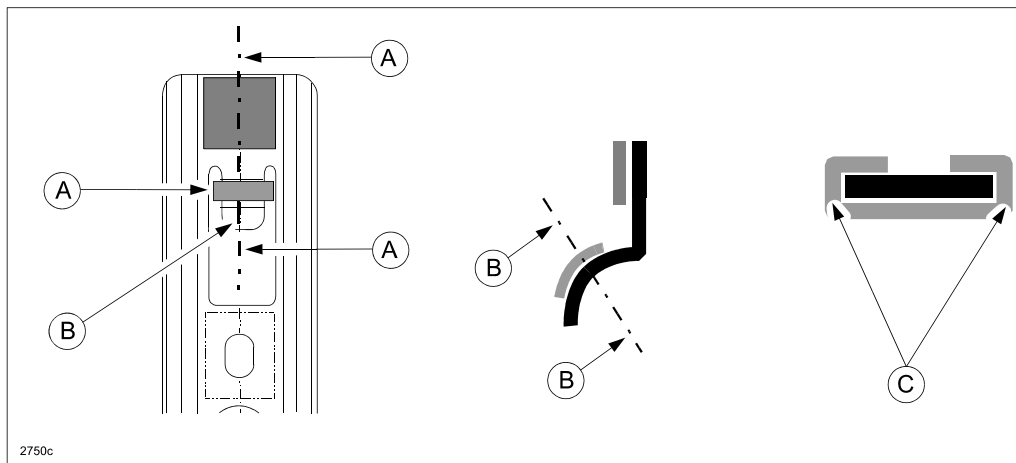

11. After the touch-up paint has dried, apply white shop grease to the area.
12. Reinstall the bumper stays on both sides.
Tightening Torque: 80-116 in. lbf. {9-13 N-m, 92-133 kgf-cm}
13. Reinstall the rear bumper to the vehicle according to the instructions on MS3 online or the Workshop Manual (section 09-10 REAR BUMPER REMOVAL/INSTALLATION).
14. Verify the repair by lightly tapping the rear bumper to confirm the noise is gone.

PART(S) INFORMATION

Part Number	Description	Qty.	Notes
TA01-76-100	Noise Repair Kit	1	Use 0.25mm thick non-woven fabric (one sheet = 7 vehicle repairs)

WARRANTY INFORMATION

NOTE:

- This warranty information applies only to verified customer complaints on vehicles eligible for warranty repair.
- This repair will be covered under Mazda's New Vehicle Limited Warranty term.
- Additional diagnostic time cannot be claimed for this repair.

Warranty Type	A
Symptom Code	82
Damage Code	97
Part Number Main Cause	KD53-52-B22 (Bumper Stay)
Quantity	0
Operation Number / Labor Hours:	XXH27XRX / 0.9 Hrs. (on or before Feb. 29, 2012 prod.) XXHB6XRX / 0.8 Hrs. (Mar. 1, 2012 to June 3, 2013 prod.)

NOTE: Do not claim the noise parts set (P/N TA01-76-100) as a related part. The amount of fabric and adhesion promotor used for this repair is included in the labor allowance.