

PREVOST

WARRANTY BULLETIN

WB13-91A

DATE :	NOVEMBER 2013	SECTION :	23 - Accessories
EXPIRATION:	NOVEMBER 2015		
SUBJECT :	WIPER MOTOR REPLACEMENT		

REVISION A THIS WARRANTY BULLETIN SUPERSEDES PREVIOUS VERSIONS
 Added removal and reinstall of MUX modules A47 & A48

APPLICATION

<i>NOTICE TO SERVICE CENTERS</i>	
<i>Verify vehicle eligibility by checking warranty bulletin status with SAP or via ONLINE WARRANTY SYSTEM available on Service / Warranty tab of Prevost website.</i>	
Model	VIN
X3-45 Commuter Model Year : 2012	 From 2PCG33495 CC735053 up to 2PCG33495 CC735232 incl.
X3-45 coaches Model Year : 2011-2012	From 2PCG33491 BC735050 up to 2PCG33491 CC735132 incl.
<p>This bulletin does not necessarily apply to all the above-mentioned vehicles, some vehicles may have been modified before delivery. The owners of the vehicles affected by this bulletin will be advised by a letter indicating the Vehicle Identification Number (VIN) of each vehicle concerned.</p>	

DESCRIPTION

On the vehicles affected by this bulletin, replace the Valeo wiper motor by a Bosch wiper motor.

MATERIAL NEEDED

Order the following parts:

Part No.	Description	Qty
800380	Wiper motor, Bosch	1

Other parts that may be required:

Part No.	Description	Qty
5001217	Cap screw M8x20 G10.9 ZP	3
5001003	Lock washer	3
9985283	242 Loctite, 250ml	A/R

NOTE

Material can be obtained through regular channels.

PROCEDURE



DANGER

Park vehicle safely, apply parking brake, stop engine. In the battery box, set the battery cut-off switch to the OFF position prior to working on the vehicle.



WARNING

Wiper mechanism can cause severe injuries. Make sure the power supply is **OFF** before plugging the connector to the motor.

WIPER MOTOR REPLACEMENT

1. Remove the dashboard access panel.

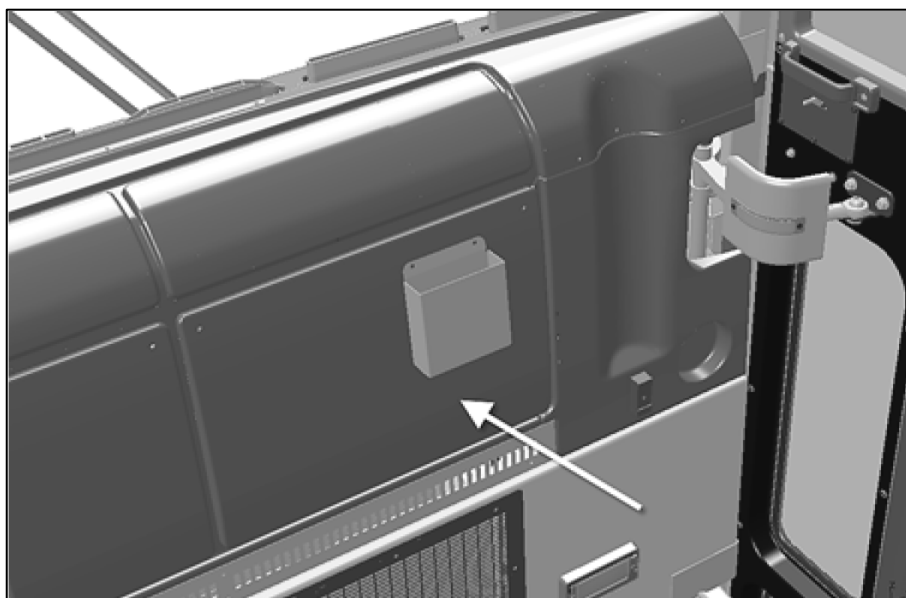

2. Remove multiplex modules A47 & A48 to gain access to the wiper motor assembly.

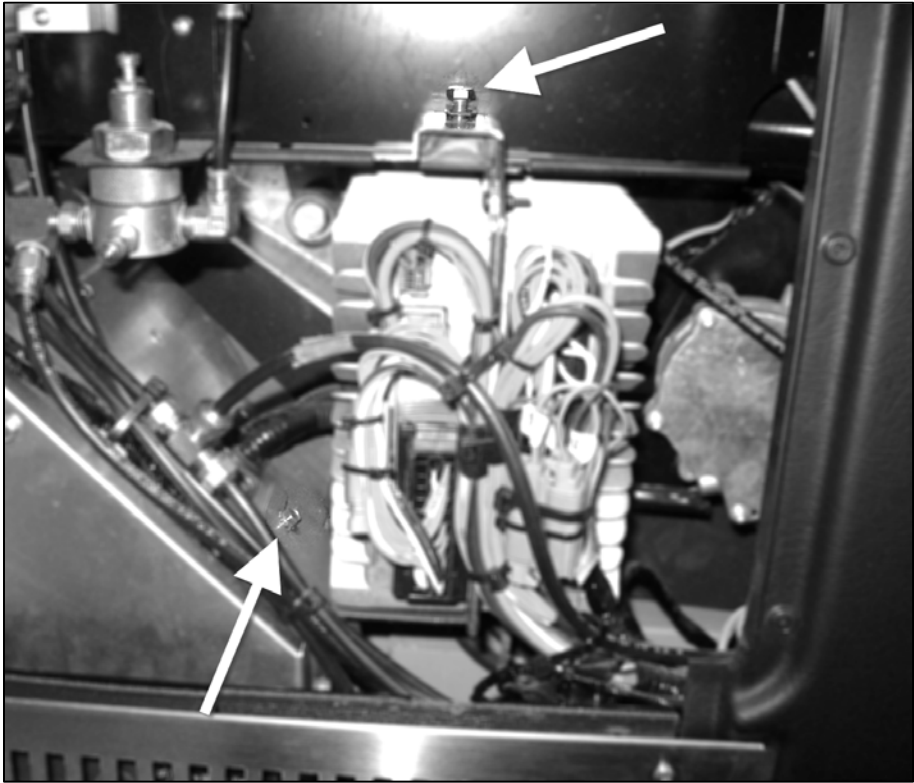

3. The wiper motor is located under the entrance door cylinder and damper.

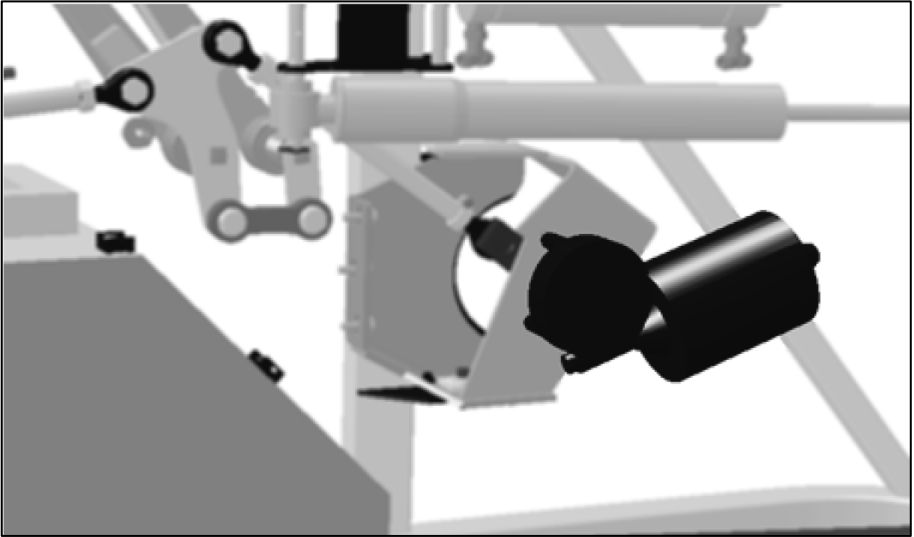

4. Unplug the electrical connector from the motor.

5. Unscrew and remove the 3 cap screws holding the motor in place.

Keep hardware for re-use.

If hardware is in bad condition or shows excessive corrosion, replace with:

5001217 Cap screw M8x20 G10.9 ZP

5001003 Lock washer

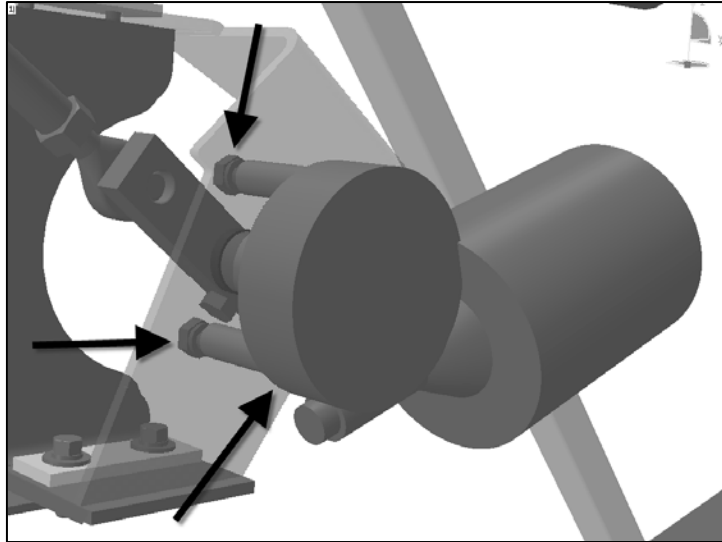

6. Loosen the screw holding the crank arm to the motor shaft and remove the motor.

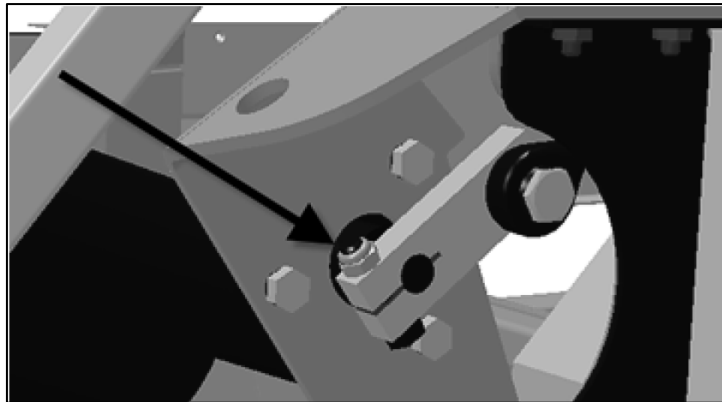

7. Install the new motor with 5001217 M8x20 screws and 5001003 lock washer.

- Assemble with Loctite
- Torque to 22 lbf-ft (dry)

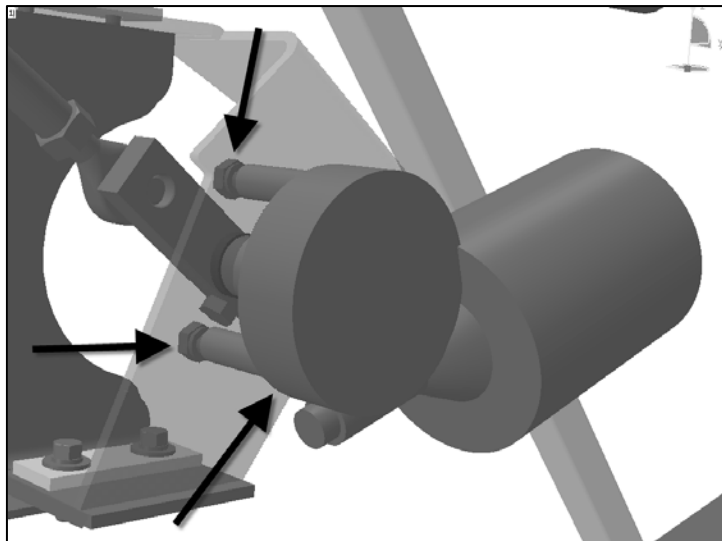

8. Make sure the battery master switch is in the OFF position. Plug the electrical connector to the motor.

9. Set the battery master switch to the ON position.

10. Momentarily turn on the wipers to allow the motor to find its park position.

11. Set the battery master switch to the OFF position and unplug the electrical connector from the motor.

12. Reinstall the crank arm on the motor shaft so that the crank arm and lever axis are aligned as shown, the lever inclined to the left.

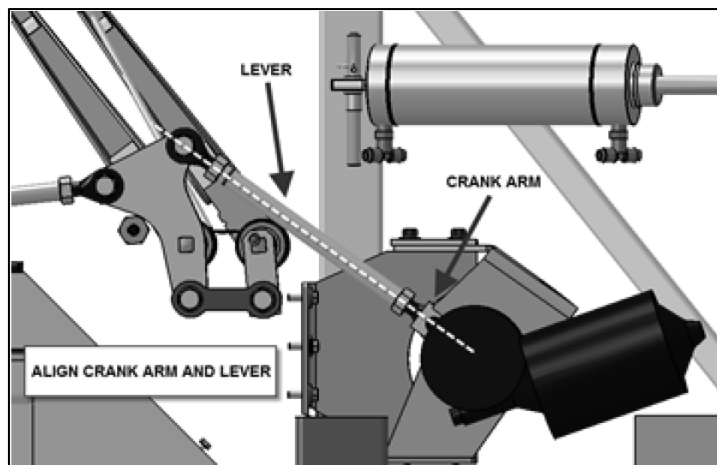

13. Tighten the screw holding the crank arm to the motor shaft.

- Torque to 22 lbf-ft

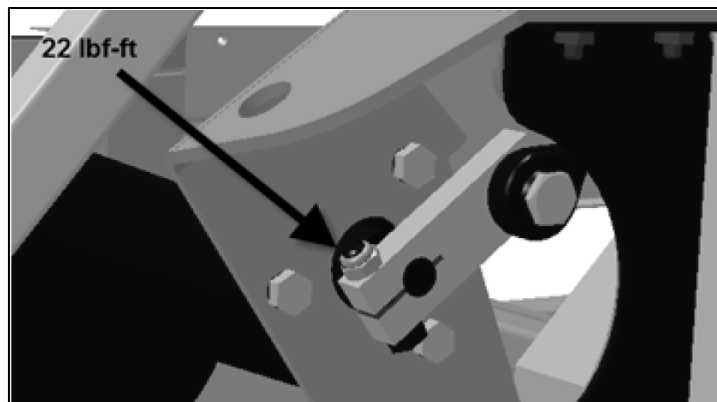

14. Make sure the battery master switch is in the OFF position. Plug the electrical connector to the motor.

15. Set the battery master switch to the ON position.

16. Ensure proper operation of the system.

17. If any adjustment is needed, set the battery master switch to the OFF position, unplug connector and make the required adjustments.

18. Reinstall multiplex modules and dashboard right panel.

PARTS / WASTE DISPOSAL

DO NOT RETURN THE REPLACED PARTS. Discard waste according to applicable environmental regulations (Municipal/State[Prov.]/ Federal)

WARRANTY

This modification is covered by Prevost's normal warranty. We will reimburse you the parts and two hour(s) (2.0h) of labor upon receipt of a warranty claim. Please submit claim via our Online Warranty System, available at www.prevostcar.com (under Service \ Warranty section). Use Claim Type: "Bulletin/Recall" and select "Warranty Bulletin WB13-91".

OTHER

VBC Bulletin	N/A
Fail Code	23.05
Defect Code	09
Syst.Cond.	B
Causal Part	800304

Access all our Service Bulletins on
<http://prevostparts.volvo.com/technicalpublications/en/pub.asp>
or scan the QR-Code with your smart phone.

E-mail us at technicalpublications_prev@volvo.com and type
"ADD" in the subject to receive our warranty bulletins by e-mail.

