

PREVOST

Instruction Sheet

IS-12143B











DEF TANK LEFT SIDE FILLER NECK RETROFIT – H3 VIP MOTORHOMES WITH CENTRAL OR SMALL A/C SYSTEM











REVISION: B THIS INSTRUCTION SHEET SUPERSEDES PREVIOUS VERSION.

New parts added to the kits

MATERIAL

Kit #042318 (SMALL A/C SYSTEM) includes the following parts:



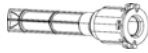







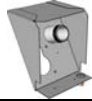





Part No.	Description		Qty
033954	FILLER NECK RECEPTACLE, WELDED ASSY		1
040991 P	HOSE, DEF FILLER 82" LONG (2085 mm)		1
040992 P	HOSE, VENT 10" LONG (255 mm)		1
040993 P	HOSE, VENT 14" LONG (355 mm)		1
041014	FILLER NECK, DEF		1
041016	FLARED TUBE, BULKHEAD (CONDENSER CMPT)		1
041018	FLARED TUBE, BULKHEAD (EVAPORATOR CMPT)		1
041019	COVER PLATE		1
500623	SCREW THREAD CUTTING PH N500 10-24x3/4		1
500957	SCREW, TAPPING BDG PH N500 #10x3/4		6
502638	WASHER, FLAT N500 .312"x.734"x.065"		1





504022	CLAMP, HOSE SS/CS 0.75" - 1.75"		1
504385	CUFF END BELLOWS 1" ½ x 2" ½ x 4"		2
504458	CLAMP 1" 5/8 ID		1
504637	CABLE TIE, NYLON		2
504745	RIVET HKL MMG 3/16x1/8		6
505111	FH PROTECTIVE COIL #22 - 1.38"		1 FT
506268	FOAM TAPE, ADHESIVE 3/8"x1/2"x25'		1
507664	CABLE TIE, NYLON DOUBLE LOOP		1
540083	RING, FILLER NECK		1
5001017	SCREW, TC HEXW Z050 10-24x1/2		1
5001730	SCREW, CAP HEXF N500 M6-1 X 16 G 10.9		4
21148722	FILLER CAP, DEF		1
82269261	INSERT, MAGNETIC FILLER NECK		1
IS-12143	INSTRUCTION SHEET		1

Additional material:

Part No.	Description	Qty
684517	SIMSON ISR 70-03 GREY, 290ml CARTRIDGE	1

Kit #042319 (**CENTRAL A/C SYSTEM**) includes the following parts:

Part No.	Description		Qty
033956	FILLER NECK RECEPTACLE, WELDED ASSY		1
040989	BRACKET, HOSE		1
040991 P	HOSE, DEF FILLER 82" LONG (2085 mm)		1
040992 P	HOSE, VENT 10" LONG (255 mm)		1
040993 P	HOSE, VENT 14" LONG (355 mm)		1
040997	DEF, SHIELD ASSY		1
041018	FLARED TUBE, BULKHEAD (EVAPORATOR CMPT)		1
041019	COVER PLATE		1
500957	SCREW, TAPPING BDG PH N500 #10x3/4		3
502568	SCREW MA PAN PH N050 M6-1x20		2
504013	MOUNT, CABLE TIE 1/4"		2
504022	CLAMP HOSE SS/CS 0.75" - 1.75"		1
504385	CUFF END BELLOWS 1" 1/2 x 2" 1/2 x 4"		1
504458	CLAMP 1" 5/8 ID		1
504527	VENT PLUG 9/32" X 41/64" x 5/8" x 1/8"		1
504637	CABLE TIE, NYLON		3

504745	RIVET HKL MMG 3/16x1/8		8
505111	FH PROTECTIVE COIL #22 - (1.38")		1 FT
506268	RUBER TAPE, ADHESIVE 3/8"x1/2"x25'		1
507664	CABLE TIE, NYLON DOUBLE LOOP		1
5001017	SCREW TC HEXW Z050 10-24x1/2		1
5001730	SCREW, CAP HEXF N500 M6-1 X 16 G 10.9		4
IS12143	INSTRUCTION SHEET		1

Additional material:

Part No.	Description	Qty
684517	SIMSON ISR 70-03 GREY, 290ml CARTRIDGE	1

NOTE

Material can be obtained through regular channels.

PROCEDURE



DANGER

Park vehicle safely, apply parking brake, stop engine and set battery master switch(es) to the OFF position prior to working on the vehicle.

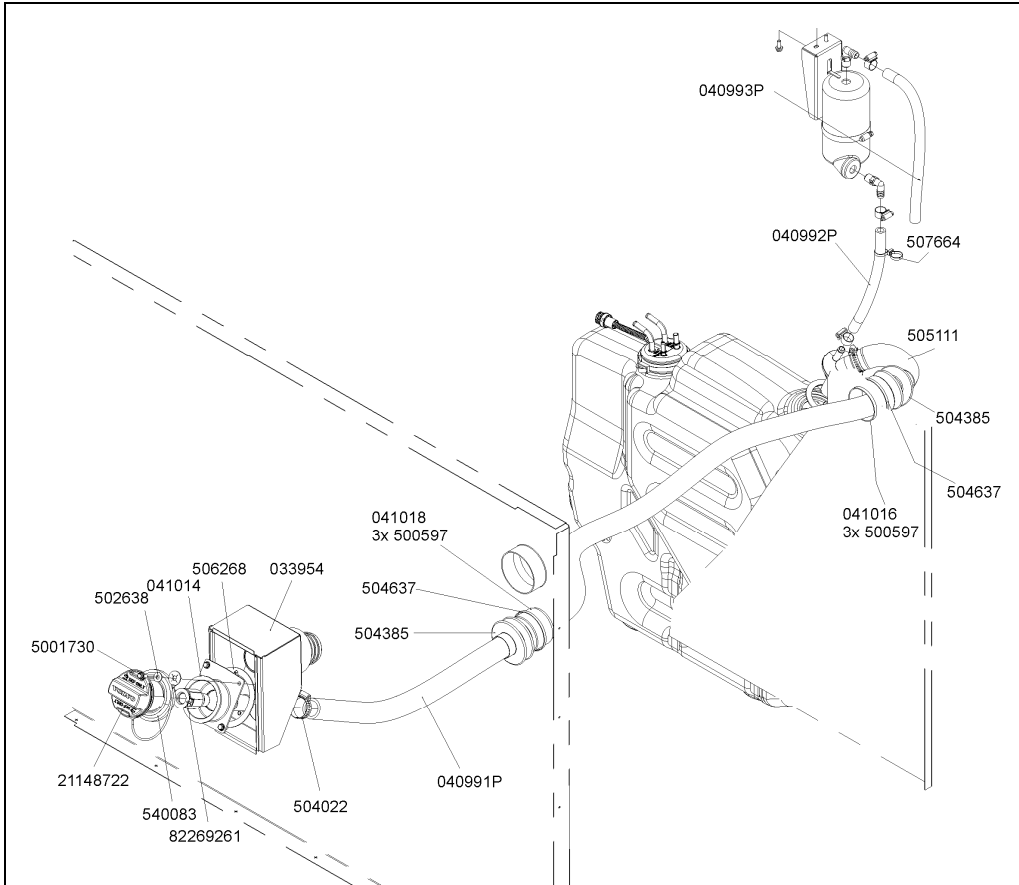

OVERVIEW - ARRANGEMENT WITH SMALL A/C SYSTEM

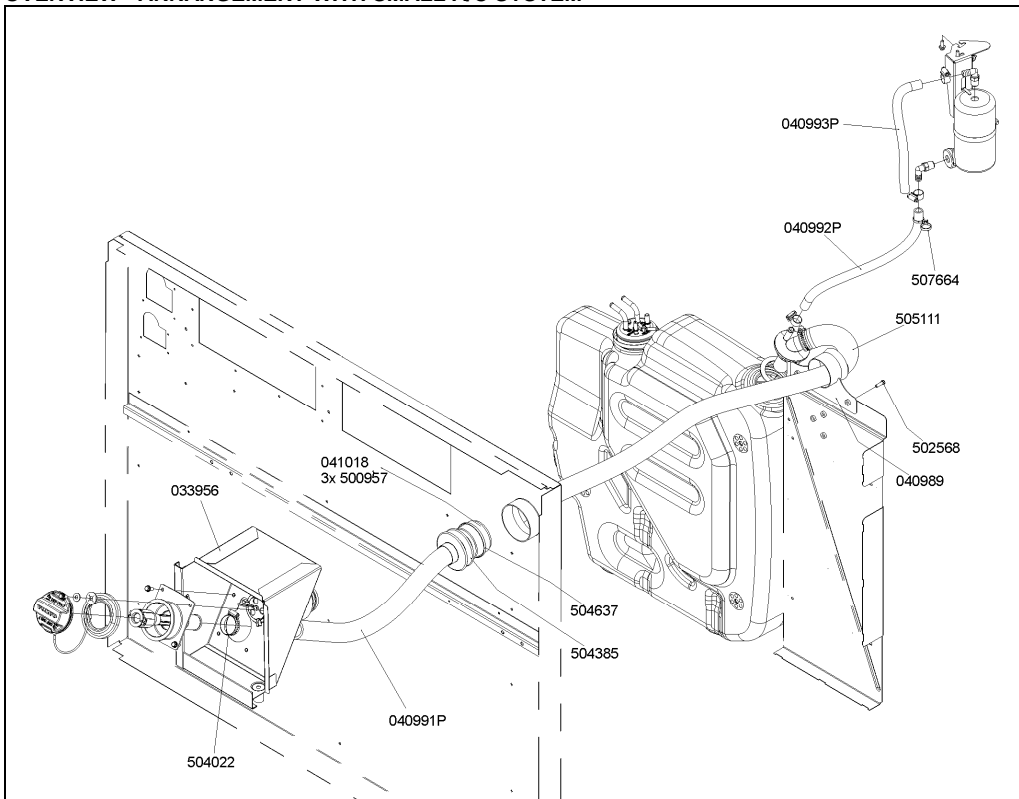

OVERVIEW - ARRANGEMENT WITH CENTRAL A/C SYSTEM

1. **ALL:** Disconnect fuel filler hose (item 14) from street side fuel filler neck receptacle (item 25). Once disconnected, protect fuel filler hose from dirt and debris. Place a plastic bag or a clean piece of cloth over the filler hose end.
2. **WITH CENTRAL A/C SYSTEM:** Remove the drain tube and fitting (item 2, 3) from the fuel filler neck receptacle. Keep for later use.

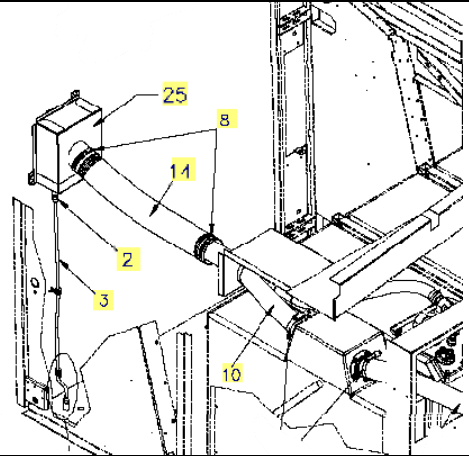

3. **WITH SMALL A/C SYSTEM:** Remove existing street side fuel filler neck receptacle (item 25). Using a cutting wheel, cut the existing fuel filler neck receptacle from the vehicle leaving 1 3/4" (44mm) of metal still welded to the vehicle in order to fasten the new fuel filler neck receptacle.

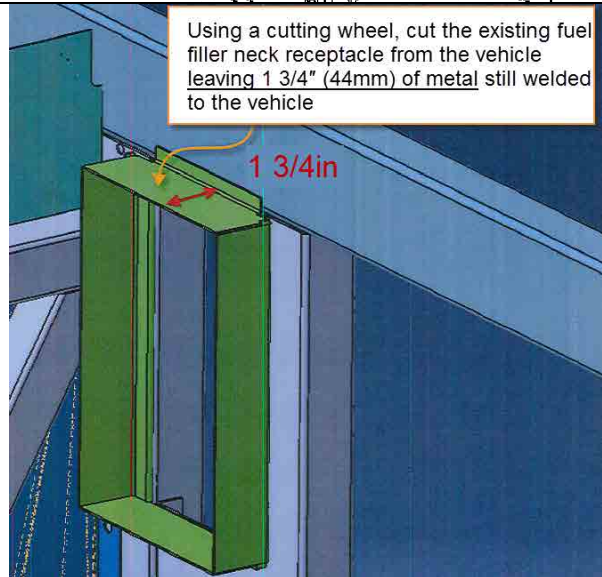

4. **WITH CENTRAL A/C SYSTEM:** Remove existing street side fuel filler neck receptacle. Using a cutting wheel, cut the existing fuel filler neck receptacle from the vehicle leaving 1 3/16" (30mm) of metal still welded to the vehicle in order to fasten the new fuel filler neck receptacle.

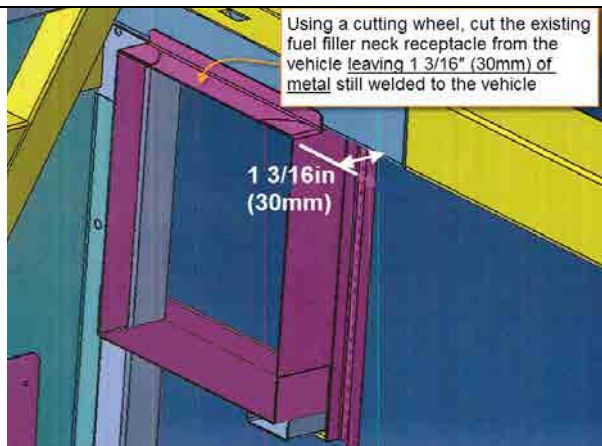

5. **WITH CENTRAL A/C SYSTEM:** To prevent inference with the drain tube fitting, cut a part of sheet metal away as described on the image at right.

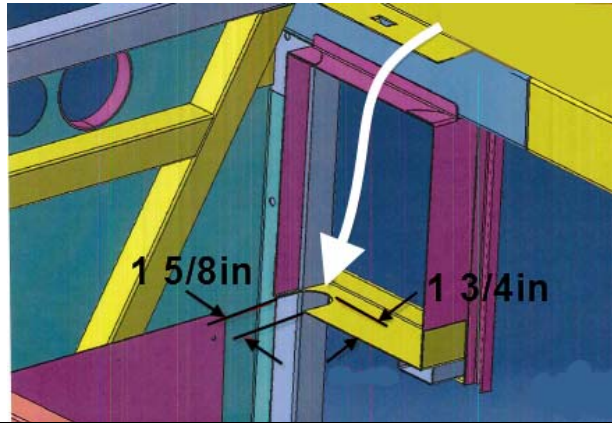

6. **ALL:** On the street side fuel tank compartment bulkhead, you must drill a 3 1/16" (77mm) diameter hole in the bulkhead, slightly under the fuel filler hose. Refer to the image at right.

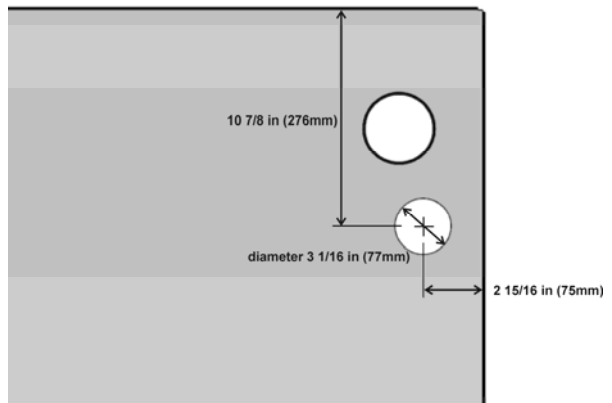
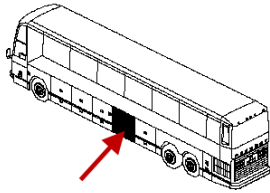

SMALL A/C EQUIPPED WITH SLIDE-OUT - STREET SIDE FUEL TANK COMPARTMENT BULKHEAD

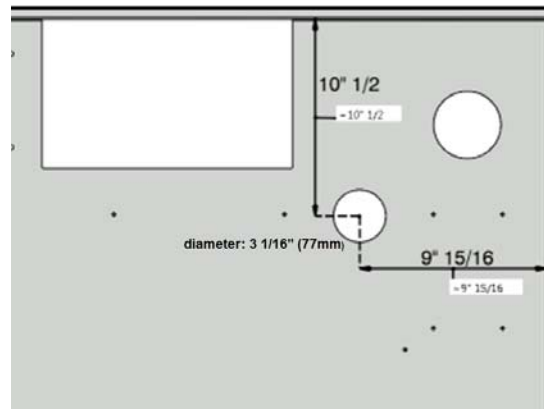

CENTRAL A/C WITH OR WITHOUT SLIDE-OUT - STREET SIDE FUEL TANK COMPARTMENT BULKHEAD

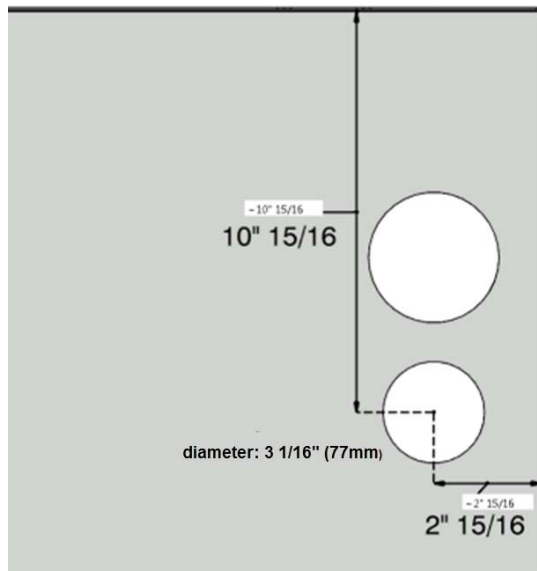

SMALL A/C WITHOUT SLIDE-OUT - STREET SIDE FUEL TANK COMPARTMENT BULKHEAD

7. **ALL:** Apply Simson ISR 70-03 sealant #684517 around the hole, prior installation of flared tube. This must be done to seal the bulkhead in order to prevent fuel odors to enter the evaporator compartment.

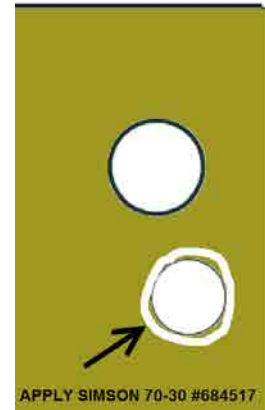
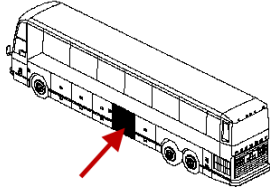

8. **ALL:** In the evaporator compartment, install the bulkhead flared tube #041018. Pre-drill 3 holes of $\text{\O} 5/32$ ". Secure with 3 tapping screws #500957.

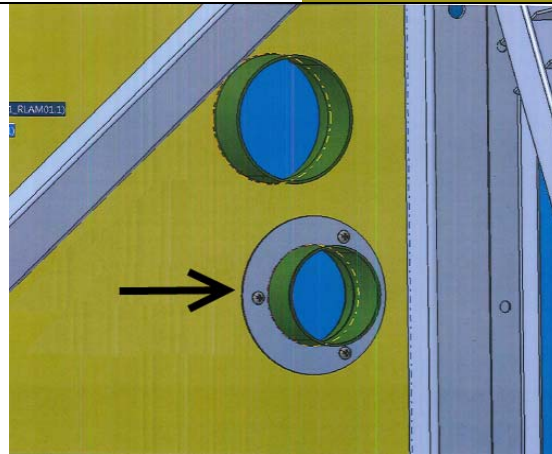
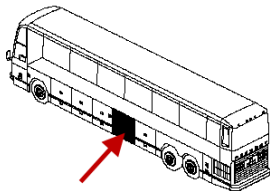

STREET SIDE FUEL TANK COMPARTMENT BULKHEAD - SEEN FROM STREET SIDE

9. **WITH SMALL A/C SYSTEM:** In the condenser compartment (or curbside compartment) you must drill a $2\ 3/4$ " diameter hole in the bulkhead. Refer to the image at right.

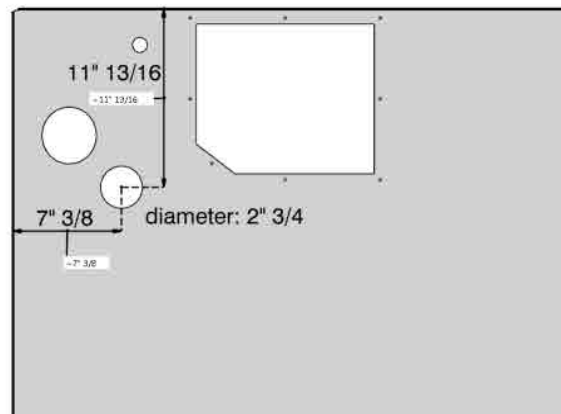
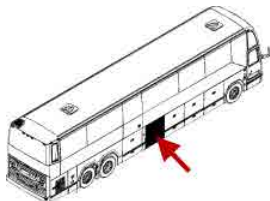

CONDENSER COMPARTMENT BULKHEAD - SEEN FROM CONDENSER SIDE

10. **WITH SMALL A/C SYSTEM:** In the condenser compartment, apply Simson ISR 70-03 sealant #684517 around the hole, prior installation of flared tube. Install the bulkhead flared tube #041016. Pre-drill 3 holes of $\text{Ø } 5/32''$. Secure with 3 tapping screws #500957.

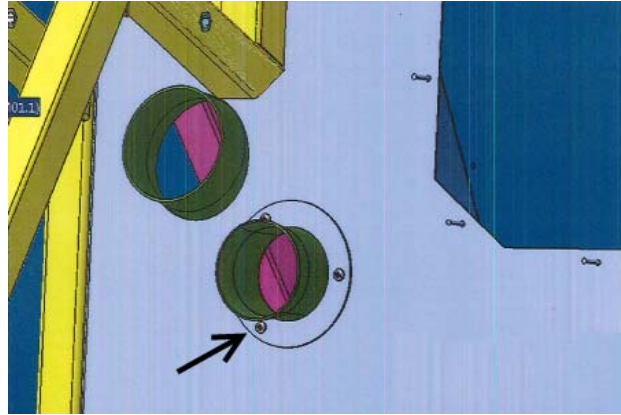
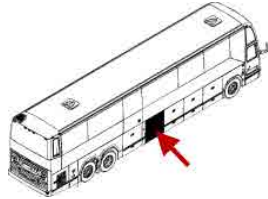

CONDENSER COMPARTMENT BULKHEAD

11. **WITH CENTRAL A/C SYSTEM:** Install hose bracket #040989 with flared side in the condenser compartment (curbside) as shown on the image at right. Drill two $\frac{1}{4}''$ diameter holes, $6\frac{1}{8}''$ center to center, through the existing panel.

Use:

2x machine screw #502568

2x cable mount #504013

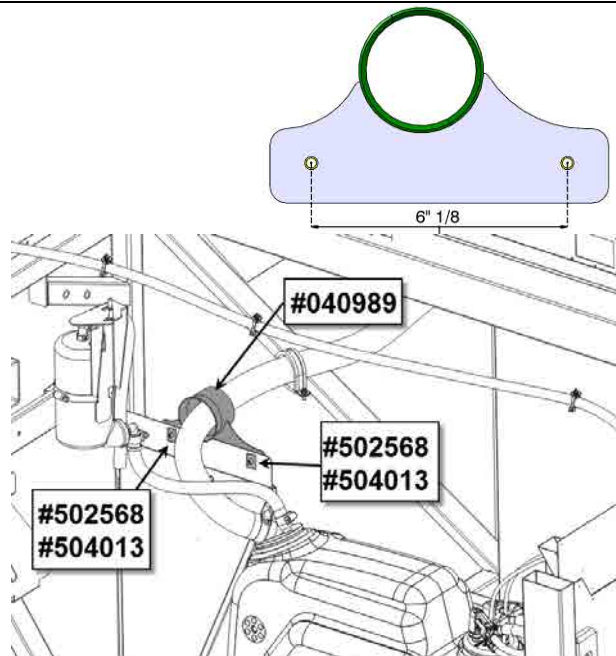
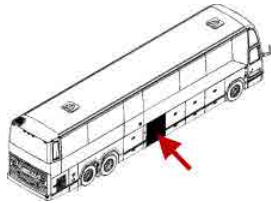

12. **WITH CENTRAL A/C SYSTEM:** Secure nearby connector on cable mount using 2 cable ties #504637.

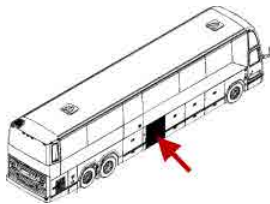

13. **ALL:** On the condenser compartment side (curbside), remove and discard the following items:

Tubes 32

Tube 31

Keep the following items for later use:

Hose clamps 37

Hose clamps 38

Cap 35 (central A/C system only)

Hardware 34, 34A (central A/C system only)

Ring 36 (central A/C system only)

Insert 44 (central A/C system only)

Filler neck 33 (central A/C system only)

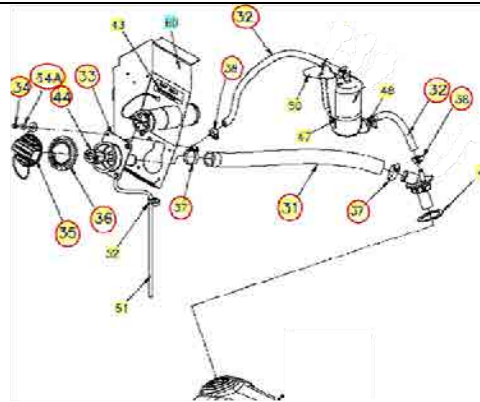

14. **ALL:** Hide the DEF filler neck hole using cover plate #041019. Fasten using 4 recovered screws #5001730 (item 34 on the image above).



15. **WITH SMALL A/C SYSTEM:** Insert DEF filler hose #040991P through FH protective coil #505111 and cuff end bellows (use soapy water to ease installation of cuff end bellows). Leave 1 inch minimum between the end of protective coil and end of hose. Protective coil purpose is to prevent hose from kinking. Connect new DEF filler hose to the DEF tank fitting and then cover the hose end and the protective coil end together with black electric tape. Fix with clamp 37 saved at previous step. Use FH protective coil to give a smooth curve to the filler hose.

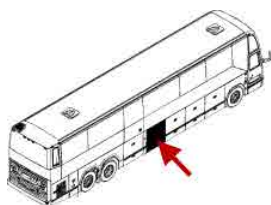
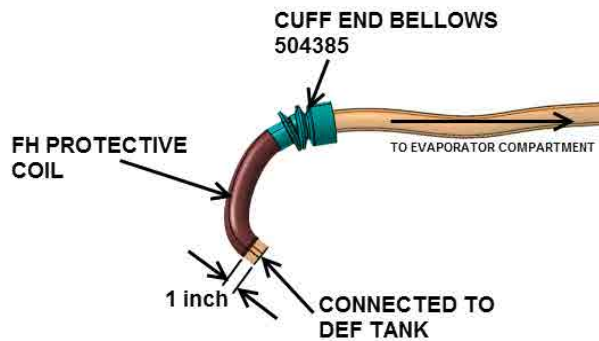

16. **WITH SMALL A/C SYSTEM:** Secure cuff end bellows #504385 onto bulkhead flared tube using one (1) nylon cable tie #504637.

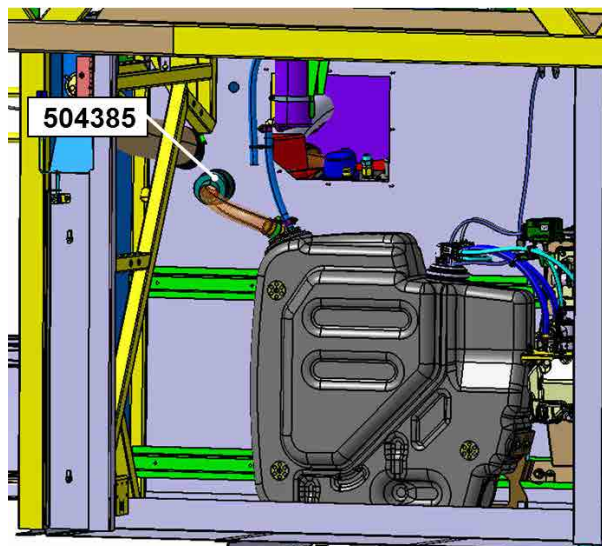
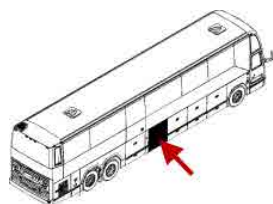

17. **WITH CENTRAL A/C SYSTEM:** Insert DEF filler hose #040991P through FH protective coil #505111. Leave 1 inch minimum between the end of protective coil and end of hose. Protective coil purpose is to prevent hose from kinking. Connect new DEF filler hose to the DEF tank fitting and then cover the hose end and the protective coil end together with black electric tape. Fix with clamp 37 saved at previous step. Use FH protective coil to give a smooth curve to the filler hose.

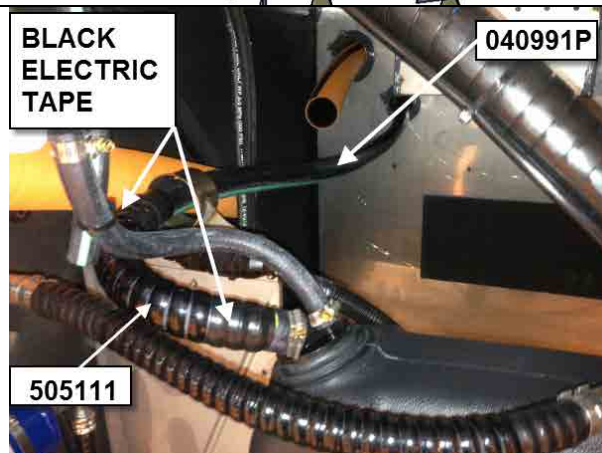
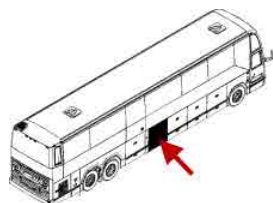

18. **ALL:** Install vent hoses tubes 040992P, 040993P onto DEF vent tank fittings as shown. Use recovered clamps. Connect the other end of tube 040992P to DEF tank adaptor.

19. **ALL:** Secure tube 040993P onto 040992P using double loop cable tie #507664.

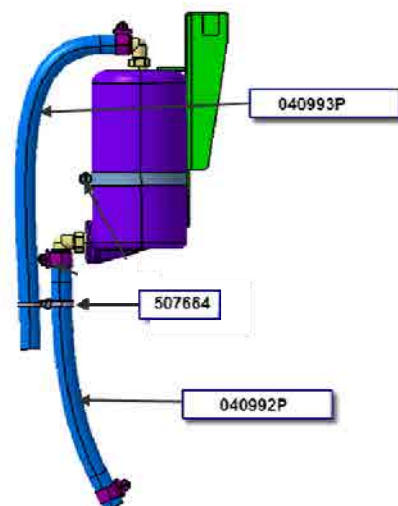
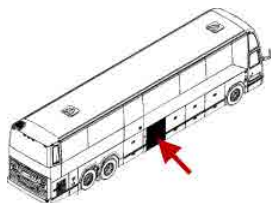

20. **ALL:** Route DEF filler hose #040991P up to the evaporator compartment (street side). Route hose over the fuel tank as shown on the image at right.

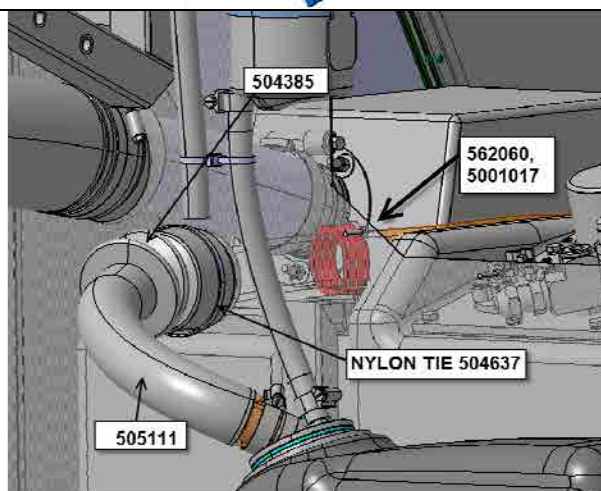
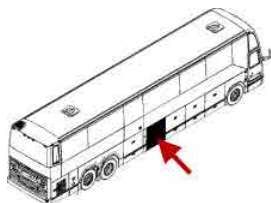

WITH SMALL A/C SYSTEM ONLY

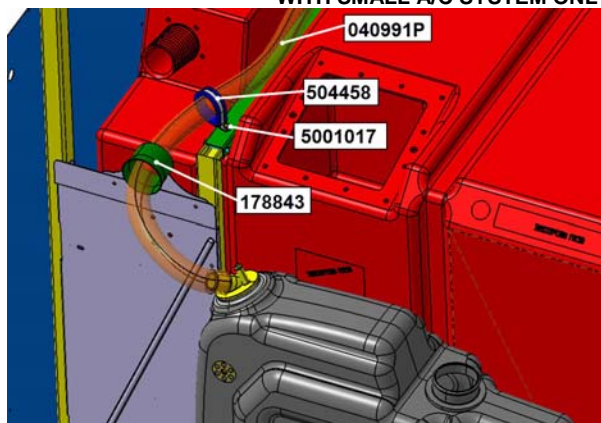

WITH CENTRAL A/C SYSTEM

21. **ALL:** Hose must be secured to fuel tank retainer as shown using hose clamp #504458 and thread cutting screw #5001017. First, drill a hole of 5/32" diameter in the retainer as shown on the image at right

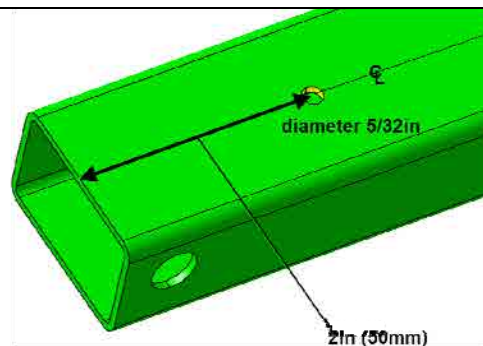

22. **WITH SMALL A/C SYSTEM:** Install the filler receptacle onto the vehicle with the metal previously left on the vehicle structure going inside the filler receptacle.

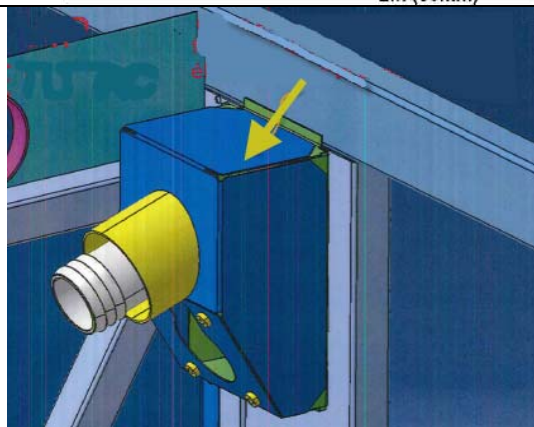

23. **WITH SMALL A/C SYSTEM:** Secure the filler receptacle using 6 rivets #504745.
2 rivets on L.H. side
2 rivets on R.H. side
1 rivet on top
1 rivet at the bottom

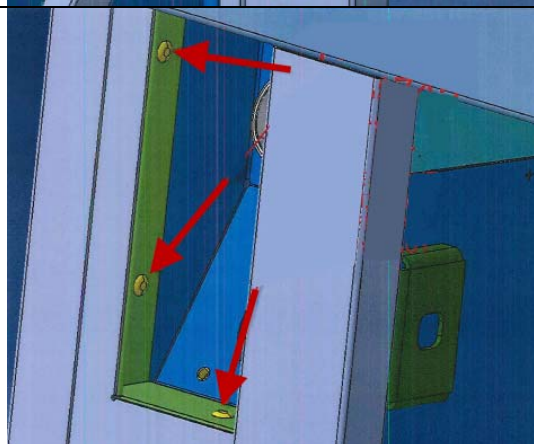

24. **WITH CENTRAL A/C SYSTEM:** Install the filler receptacle onto the vehicle with the metal previously left on the vehicle structure going inside the filler receptacle.

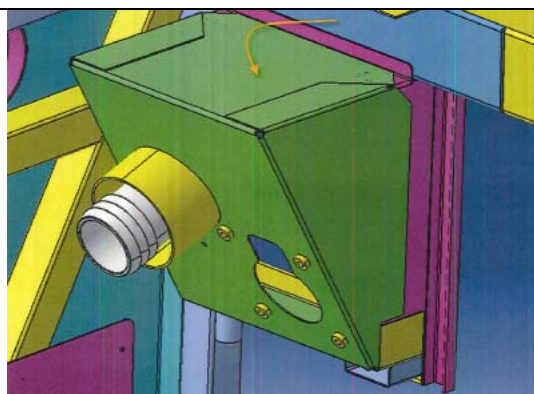

25. **WITH CENTRAL A/C SYSTEM:** Secure the filler receptacle using 8 rivets #504745.
 2 rivets on L.H. side
 2 rivets on R.H. side
 2 rivet on top
 2 rivet at the bottom

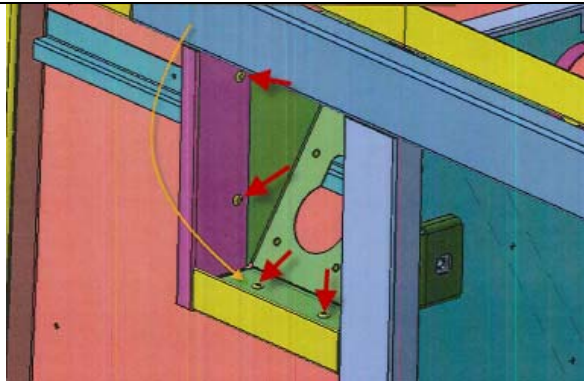

26. **ALL:** Ensure tightness of the filler receptacle. Apply Simson ISR 70-03 sealant #684517 as required.

27. **WITH SMALL A/C SYSTEM:** Assemble filler neck assy. On the filler neck insert #82269261, cut and discard the hatched are, i.e. at the beginning of the strainer. A strainer is already installed in the DEF tank neck.

If kept in place, this strainer will induce back flow.

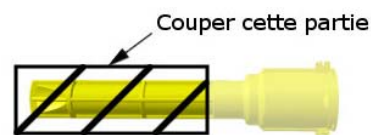

CUT AND REMOVE THE STRAINER

28. **WITH SMALL A/C SYSTEM:** Push down the magnet equipped insert to the bottom of the filler neck until neck and insert interlock.

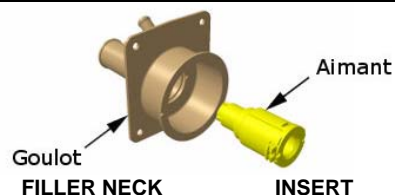

29. **WITH SMALL A/C SYSTEM:** Install filler neck ring #540083. Push firmly until filler neck and ring interlock.

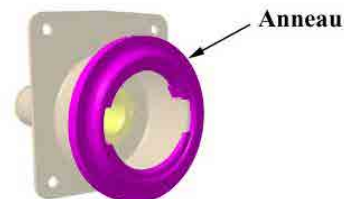

RING

30. **WITH SMALL A/C SYSTEM:** Apply adhesive foam tape #506268 under the filler neck as shown on the image at right.

**START AND END
FOAM TAPE HERE**

début / fin
du ruban



Ne pas boucher
les trous
**KEEP 4 HOLES
CLEAR**

égal au
bord
**FOAM TAPE FLUSH
WITH FILLER NECK
EDGE**

31. **WITH CENTRAL A/C SYSTEM:** Screw filler neck cap #21148722.

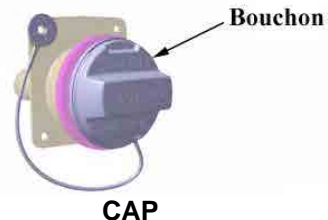

32. **WITH SMALL A/C SYSTEM:** Install DEF filler neck assembly onto filler neck receptacle using four (4) screws #5001730 and one (1) washers #502638 as shown.

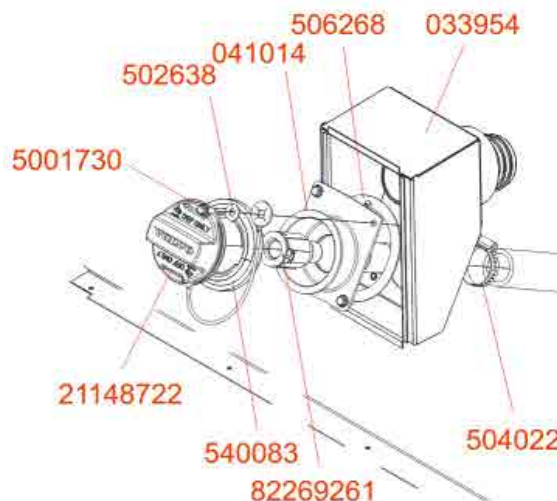

33. **WITH CENTRAL A/C SYSTEM:** Take DEF filler neck recovered from previously removed curbside filler neck receptacle and install in new filler neck receptacle using 4 screws #5001730. Take note you must plug DEF filler neck vent fitting using included rubber vent plug #504527. Glue rubber plug using Simson 70-03 sealant #684517.

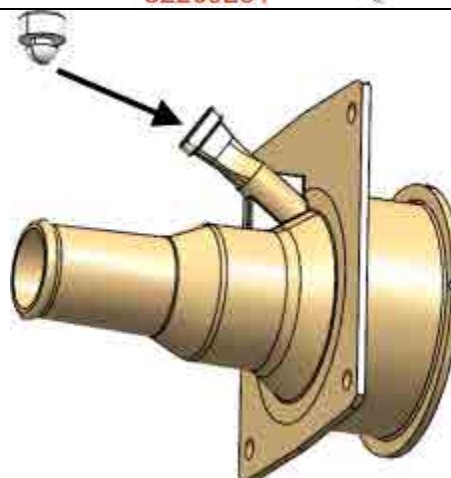

34. **ALL:** In the evaporator compartment, slip the hose through cuff end bellows #504385. Secure cuff end bellows onto bulkhead flared tube using one (1) nylon cable tie #504637.

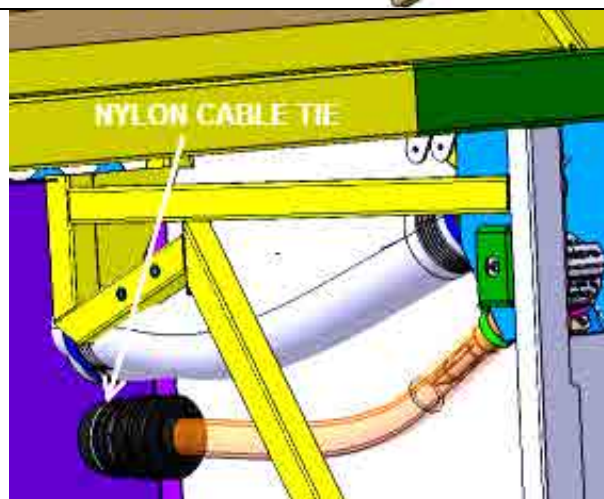
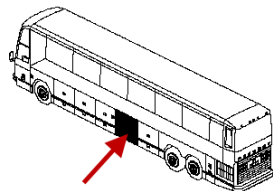

35. **ALL:** Connect hose to DEF filler neck fitting as shown. Place clamp #504022 screw on top.

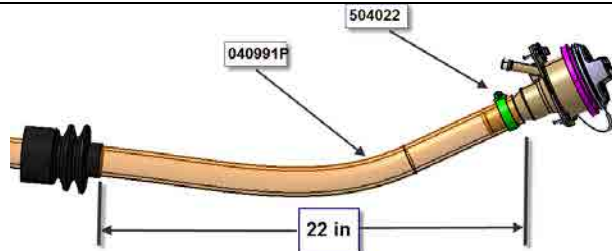

36. **ALL:** Dismount fuel filler neck cap from former filler neck receptacle and install similarly to new filler neck receptacle. Apply Simson 70-03 sealant #684517 around filler neck tube.

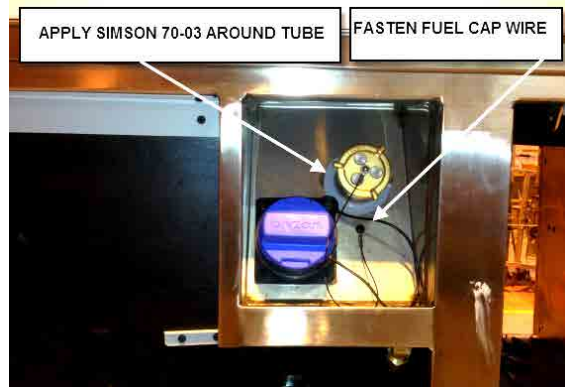

37. **WITH SMALL A/C SYSTEM:** You must relocate the fuel filler cap wire attachment point to prevent the cap from passing through the opening at the bottom and being caught between the structure and the lower fiber panel.

Secure fuel cap wire using one thread cutting screw #500623.



38. **ALL:** Connect fuel filler hose to fuel filler neck.

39. **ALL:** Connect fuel filler hose and protective corrugated tube to filler neck adaptor.

40. **WITH CENTRAL A/C SYSTEM:** Reinstall filler neck receptacle drain tube. Use liquid Teflon #680098 on fitting threads.

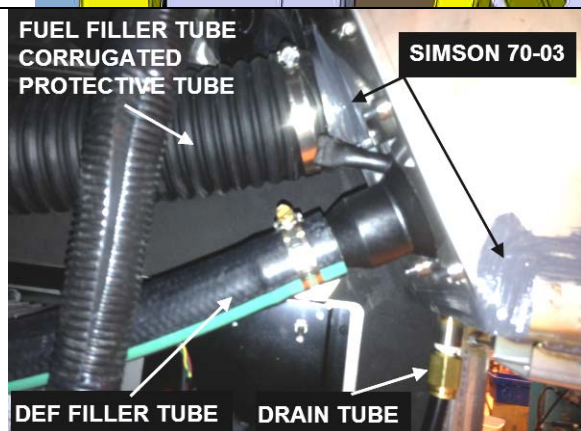

41. **WITH CENTRAL A/C SYSTEM:** Install DEF shield #040997 onto evaporator (curbside) door using existing hinge hardware as shown.

