

# PREVOST

## WARRANTY BULLETIN

**WB13-28**

DATE :	AUGUST 2013	SECTION : 18 - Body
EXPIRATION:	AUGUST 2015	
SUBJECT :	<b>REINFORCEMENT OF ENGINE COMPARTMENT DOOR PANTOGRAPH ARM</b>	

### APPLICATION

<i>NOTICE TO SERVICE CENTERS</i>	
<i>Verify vehicle eligibility by checking warranty bulletin status with <b>SAP</b> or <b>Vehicle Warranty Information</b> tool found on Prevost–Systems tab of the Volvo Trucks Dealer Portal</i>	
Model	VIN 
H3-41, H3-45 Coaches Model Year : 2012	From 2PCH33494CC71 <b>1940</b> up to 2PCH33414CC71 <b>2072</b> incl. Excluding 2PCH33495CC71 <b>2067</b> and 2PCH33497CC71 <b>2068</b>
H3-41, H3-45 VIP Converted Coach Shells Model Year : 2012	From 2PCH33494CC71 <b>1943</b> up to 2PCH33414CC71 <b>2051</b> incl.
<p><b>This bulletin does not necessarily apply to all the above-mentioned vehicles, some vehicles may have been modified before delivery. The owners of the vehicles affected by this bulletin will be advised by a letter indicating the Vehicle Identification Number (VIN) of each vehicle concerned.</b></p>	

### DESCRIPTION

On the vehicles affected by this bulletin, it may be necessary to reinforce the gas springs attachment bracket on the pantograph arm retaining the engine compartment door.

Inspect the pantograph arm bracket on these vehicles following the procedure below and add a reinforcing block to the bracket as required.

## INSPECTION PROCEDURE

1. Open the engine compartment door and locate the pantograph arm and the three (3) gas springs (right side of the vehicle).



Fig. 1

2. The inside of the bracket must be welded *at least at one* of the two points shown on fig.2 (horizontal or vertical weld).

**NOTE: Some brackets may have been welded at both horizontal and vertical points.**

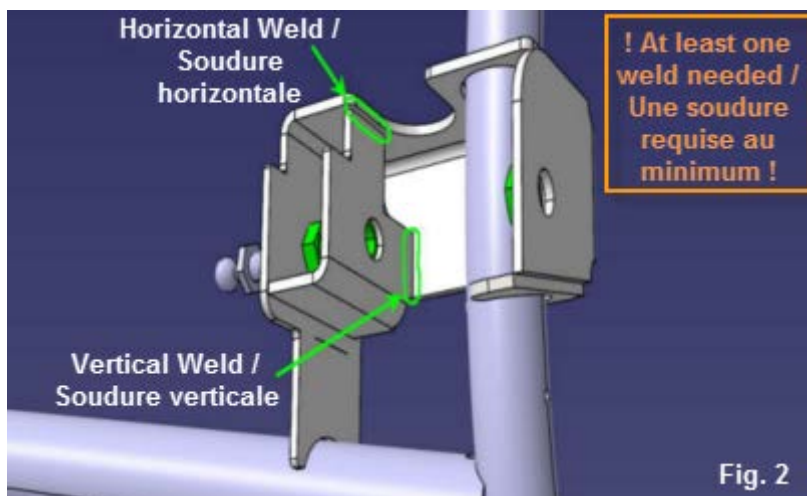

Fig. 2

3. If the inspection reveals that *both* welds are missing, like shown in fig.3, a reinforcing block will have to be added to the bracket.

Furthermore, if both welds are missing from the brackets, inspection of the engine door gas springs is required.

The complete procedure and parts list to perform the reinforcing block installation and gas springs inspection is described below.

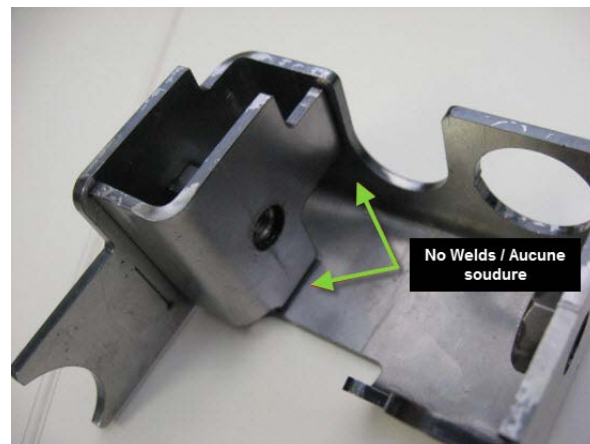

Fig.3

## GAS SPRINGS INSPECTION PROCEDURE

If both welds of the pantograph arm bracket are missing, the three (3) gas springs must be inspected to ensure that their mounting points (heads) are not bent or distorted.

Both heads on each gas springs must be parallel to the gas spring body.

If any gas spring head is bent (as shown in Fig.4), the gas spring must be replaced.

### CAUTION!

The engine compartment door is heavy and must be supported before any of the gas spring can be removed from the bracket.



Fig.4

## MATERIAL

Order the following part(s):

Part No.	Description	Qty
7770024	KIT, Reinforcement for Pantograph Arm	1

Other part(s) that may be required:

Part No.	Description	Qty
980030	Gas Spring	As Req.

### NOTE

Material can be obtained through regular channels.

## REINFORCEMENT BLOCK INSTALLATION PROCEDURE



### DANGER

Park vehicle safely, apply parking brake, stop engine and set battery master switch(es) to the OFF position prior to working on the vehicle.

To install bracket reinforcement block, a hole must be first drilled at the top of the support using the supplied drilling template. This will allow the block to be tightened to the support with an M6 Allen screw.

First install the drilling template to the bracket, securing it with a pair of locking pliers (Fig.5).

**NOTE:** Removal of the gas springs is not necessary to install the reinforcement block to the bracket.

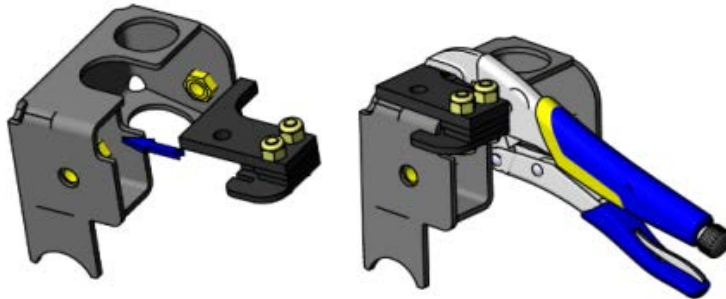

Fig.5

**NOTE:** Before drilling the bracket, double check that the drilling template ear fits flush with the bracket at the two positions shown (Fig.6).



Fig.6

With the drilling template snugly fitted to the bracket, drill through the bracket using an 8mm HSS drill bit (Fig.7).

Remove the drilling template and thoroughly de-burr top and bottom edges of the hole in the bracket using a small file.



Fig.7

Install the two parts reinforcing block to the bracket by following the steps below.

1. Insert the back part of the block (part #1) in the bottom opening of the bracket (locating tang on the block must fit the bracket as shown on fig.9).
2. From the previously drilled 8mm hole, hand tight the rear part of the block to the bracket using the supplied M6 Allen screw and lock washer, (block should be allowed to move slightly).
3. Fit the front part of the block to the bracket (part #3).
4. Using the two supplied M4 Allen screws and lock washers, hand tight the front and back section of the block together.
5. Tighten the M6 screw to 13ft-lb (18N-m).
6. Finish by tightening the M4 Allen screws to 4ft-lb (5N-m).

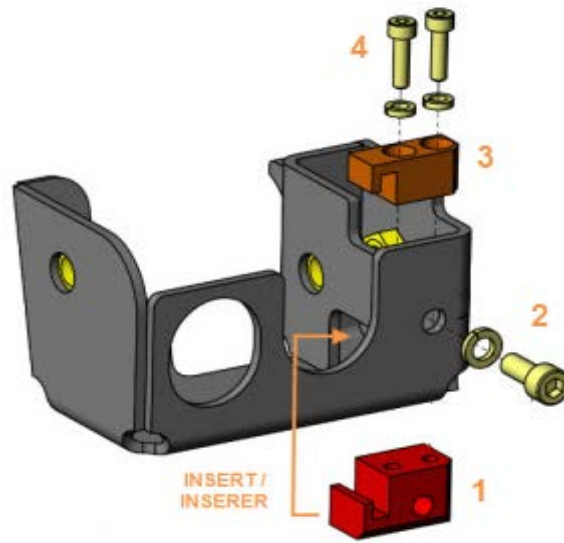

Fig.8



Fig.9

The reinforcing block installation is now completed; Fig.10 shows the block in place in the bracket.

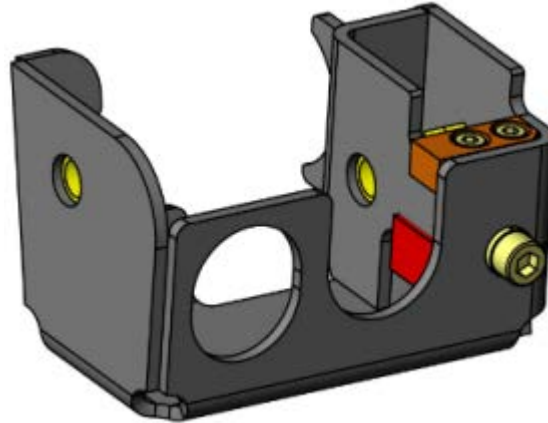

Fig.10

## PARTS / WASTE DISPOSAL

Return replaced parts to Prevost with A.F.A. for full reimbursement.  
Discard waste according to applicable environmental regulations (Municipal/State[Prov.]/ Federal)

## WARRANTY

This modification is covered by Prevost's normal warranty. We will reimburse you the parts and one hour (1.0) of labor upon receipt of the replaced parts and a completed A.F.A. form on which you must specify as per "Warranty Bulletin WB13-28".

## OTHER

VBC Bulletin	n/a
Fail Code	09
Defect Code	18.05
System Condition	B
Causal Part	289717

Access all our Service Bulletins on <http://prevostparts.volvo.com/technicalpublicatios/en/pub.asp>  
Or scan the QR-Code with your smart phone.

E-mail us at [technicalpublications\\_prev@volvo.com](mailto:technicalpublications_prev@volvo.com) and type "ADD" in the subject to receive our warranty bulletins by e-mail.

