

PREVOST

WARRANTY BULLETIN

WB13-49

DATE :	JULY 2013	SECTION : 04 - Exhaust
EXPIRATION:	JULY 2015	
SUBJECT :	UREA QUALITY SENSOR 21891229 REPLACEMENT	

APPLICATION

NOTICE TO SERVICE CENTERS

*Verify vehicle eligibility by checking warranty bulletin status with **SAP** or **Vehicle Warranty Information** tool found on Prevost-Systems tab of the Volvo Trucks Dealer Portal*

Model	VIN	
X3-45 Coach Model-year: 2013	Single vehicle 2PCG33499 <u>DC735316</u> .	
H3-45 VIP Model-year: 2013	Single vehicle 2PCVS349X <u>DC712248</u>	
Le Mirage XLII Entertainer Model-year: 2013	Single vehicle 2PCYS3492 <u>DC735374</u>	

This bulletin does not necessarily apply to all the above-mentioned vehicles, some vehicles may have been modified before delivery. The owners of the vehicles affected by this bulletin will be advised by a letter indicating the Vehicle Identification Number (VIN) of each vehicle concerned.

DESCRIPTION

On the vehicles affected by this bulletin, replace the prototype version of the Urea Quality Sensor #21891229 by the production version of the sensor #22073036.

MATERIAL

Order the following parts:

Part No.	Description	Qty
22073036	Urea Quality Sensor	1

NOTE

Material can be obtained through regular channels.

SPECIAL TOOLS:

Part No.	Description	Qty
688952 	Extractor tool	1

PROCEDURE



DANGER

Park vehicle safely, apply parking brake, stop engine and set battery master switch(es) to the OFF position prior to working on the vehicle.



AVERTISSEMENT

When disconnecting hoses and components, do not spill DEF onto separated connectors. If this occurs, replace the connectors immediately. Cleaning with water or compressed air will not help as the DEF quickly oxidizes metal and, due to capillary action, “creeps” along cabling at a speed of about 0.6 meters/hour.



WARNING

DEF spilt onto hot components will quickly vaporize. Turn your face away!



WARNING

Aftertreatment DEF is an irritant. Contact with DEF can irritate the skin and eyes. Inhaling DEF mist can cause lung irritation. Avoid DEF contact with skin and eyes. Avoid breathing mist created by DEF spray.

NOTE

1. If the DEF lines will remain open for an extended period of time, seal the opening to prevent crystallization of fluid in the line.
2. Note: Before removing appropriate coolant and DEF lines, please mark them to ensure proper reinstallation to the correct location

1. In the condenser compartment, locate the DEF tank.



H series shown

2. Disconnect the electrical harness from the DEF quality sensor module electrical connector (1).

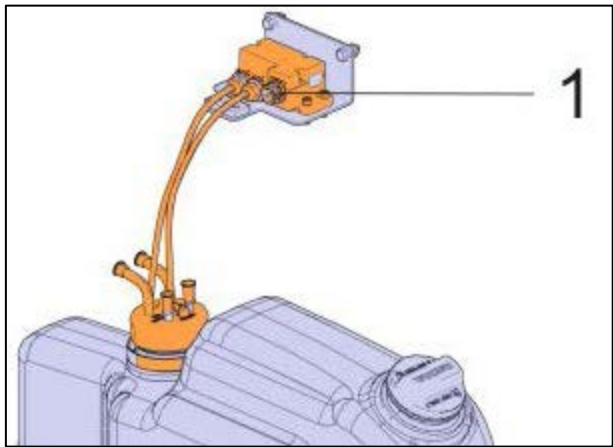

(1) Connector on UQS module

3. Modify connector pin out according to FIGURE 2.
4. *Protect with a plastic bag to avoid any DEF contamination.*

Figure 1 : UQS 22073036 Pin-out

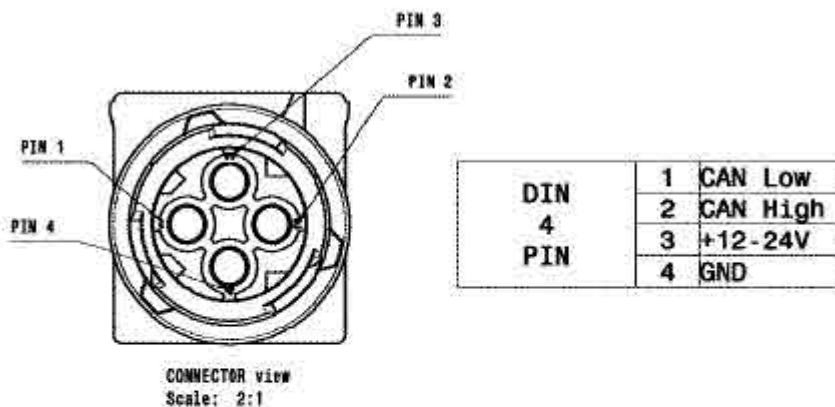
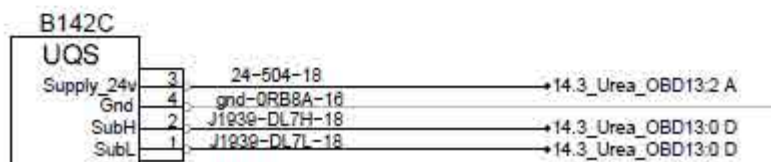
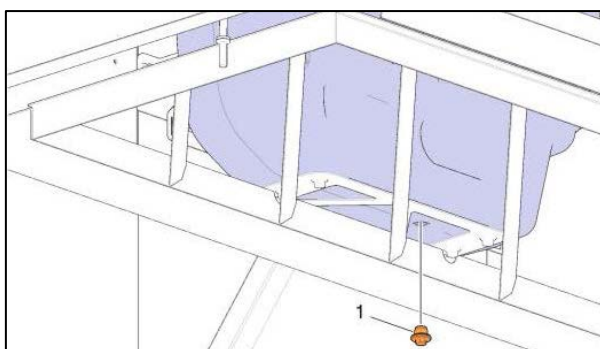

Figure 2 : Schematic of connector



REMOVAL

5. Clamp the heating hoses. Drain any coolant in an appropriate container.
6. Place a container under the DEF tank to collect any spilt DEF fluid or coolant.
7. Remove tank bottom plug and empty in an appropriate container.
8. Once the tank is empty, reinstall plug and tighten.



9. Disconnect coolant and DEF hoses.
Note their position to ease re-assembly.

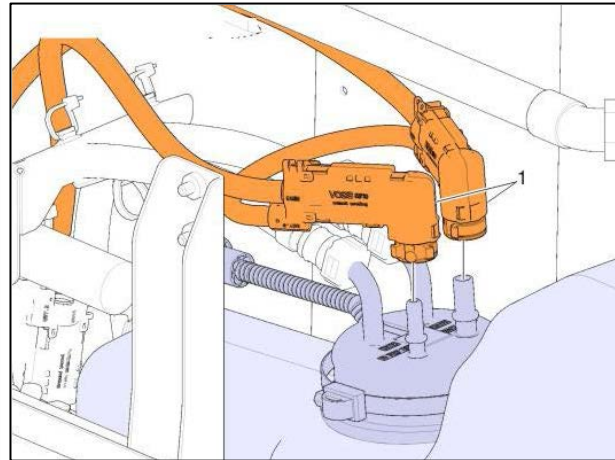
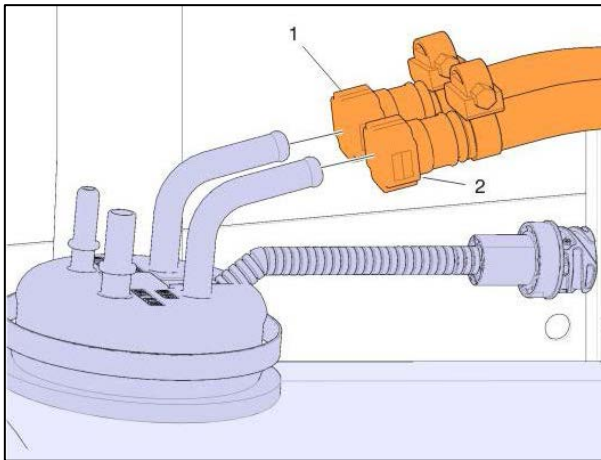

10. Loosen clamps and remove the hoses from the filler cap



11. Remove tank to create space to install new module.

Note: On X-series vehicles, the DEF pump must be moved to remove the tank.

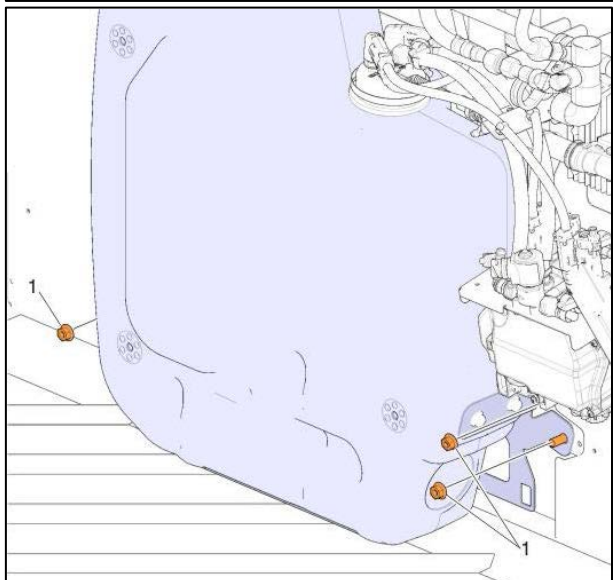

12. Loosen the clamp holding the sensor and remove from tank.

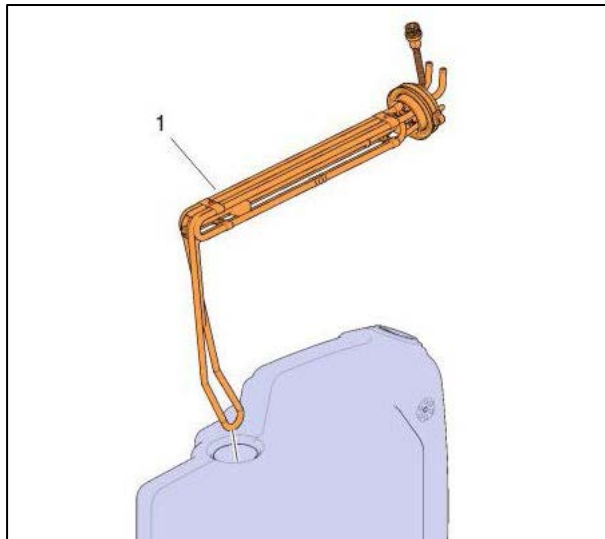
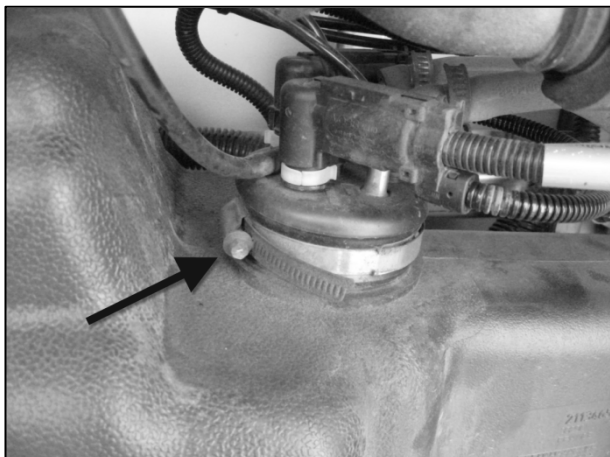

13. Un screw the four mounting screws on the electronic module. Reserve for future assembly.

INSTALLATION

14. Insert the new sensor in the DEF tank and install new electronic module.

Handle the new sensor with care to avoid damage to the sensor.

- Tighten module screws to 106 lbf-in.
- Tighten clamp to 29 lbf-in



15. Install tank on vehicle.

On X-series vehicles, install the pump.

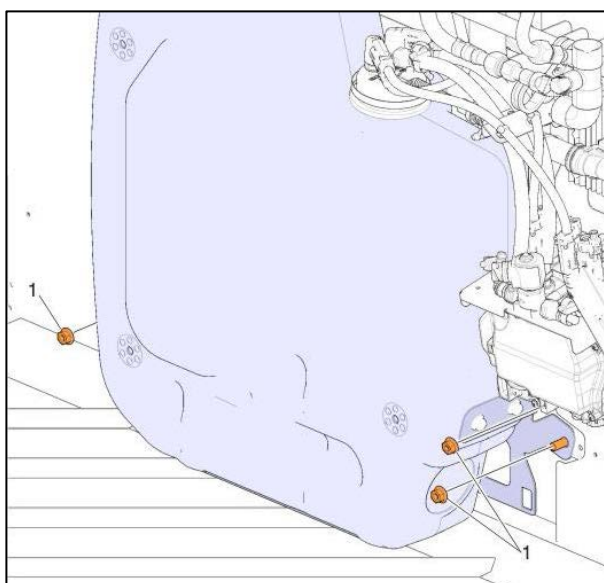

16. Install all hoses on the sensor cap and DEF tank filler cap.

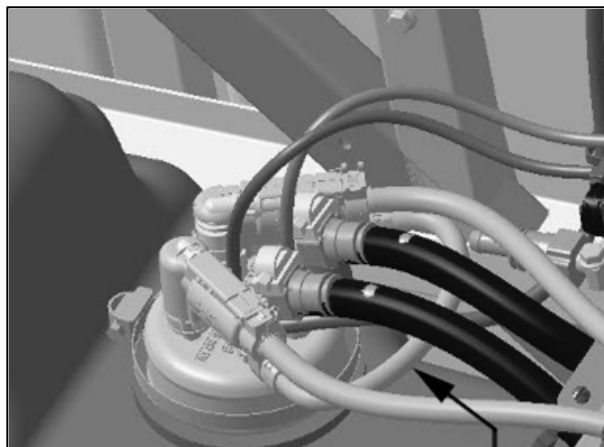

17. Remove the plastic bag on the connector and connect to electronic module.

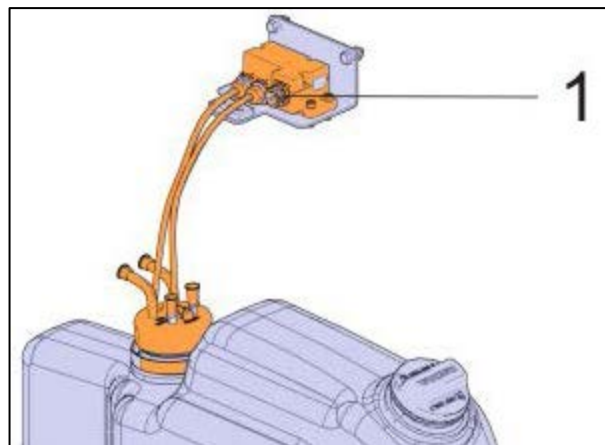

18. Fill the tank with new DEF fluid.

19. Remove clamps on the heating system hoses and fill system with coolant saved earlier.

20. Use tech tool to remove any error code present (DTC) and perform "Learned Data Set"

21. Start vehicle, detect any leaks and make sure all systems operate properly.

PARTS / WASTE DISPOSAL

Return replaced parts to Prevest with A.F.A. for full reimbursement.

WARRANTY

This modification is covered by Prevest's normal warranty. We will reimburse you the parts and three hours (3.0h) of labor upon receipt of the replaced parts and a completed A.F.A. form on which you must specify as per "Warranty Bulletin WB13-49".

OTHER

VBC Bulletin	S6210
Fail Code	04.04-1
Defect Code	09
System Condition	B
Causal Part	21891229

Access all our Service Bulletins on <http://prevostparts.volvo.com/technicalpublicatios/en/pub.asp>
Or scan the QR-Code with your smart phone.

E-mail us at technicalpublications_prev@volvo.com and type "ADD" in the subject to receive
our warranty bulletins by e-mail.

