

## Birmingham: Coolant Recovery Tank Installation



**Prepared by:** Kalman Takacs  
Field Service Engineer  
256-241-1243

**Approved By:** Dan Allen  
Chief Engineer

**Property and Top Bus Number:** Birmingham 31LFW-06, 283000

**Issue:** Coolant recovery tank installation.

**Reason/ cause:** The cooling system was updated to enhance serviceability.

**Solution:** Install coolant recovery tank per this work instruction.

## Birmingham: Coolant Recovery Tank Installation



**Number of affected buses:** 12 buses

**Estimate repair hours/bus:** 45 minutes

### **Necessary parts:**

TANK, COOLANT RECOVERY, 6 QT,	P/N: <b>500-1315-021,</b>	1/bus,
BRKT COOLANT RECOVERY TANK LFW,	P/N: <b>529-1315-001,</b>	1/bus,
BRKT COOLANT RECOVERY TANK LFW,	P/N: <b>529-1315-005,</b>	1/bus,
SLOTTED BAR, 90, 2 SLOTx2 SLOT,	P/N: <b>100-2306-015,</b>	1/bus,
CLAMP, HOSE, SILICONE/SS, 3/4"ID,	P/N: <b>5001795,</b>	2/bus,
CLAMP, HOSE, SILICONE/SS, 3-1/2ID,	P/N: <b>516-1319-002,</b>	1/bus,
CLAMP, BAND, SS, 7/16" TO 25/32",	P/N: <b>416.01.1355.901,</b>	3/bus,
HOSE, SILICONE, 4-PLY, 5/16 ID,	P/N: <b>500-1315-039,</b>	3ft/bus,
WASHER, FLAT, 1/4, ZN, GR 8,	P/N: <b>2604,</b>	9/bus,
NUT, 1/4-20, HEX, NYLOCK,	P/N: <b>210420N,</b>	7/bus,
BOLT, 1/4-20x1, HEX, ZN, GR8,	P/N: <b>220420088,</b>	7/bus,
WASHER, FLAT, 3/8, ZN, GR 8, USS,	P/N: <b>2606,</b>	5/bus,
NUT, 3/8-16, HEX, ZN, YW, GR 8,	P/N: <b>200616,</b>	3/bus,
WASHER, LOCK, 3/8, ZN,	P/N: <b>2506,</b>	2/bus,
BOLT, 3/8-16x1-1/4, HEX, ZN, GR8,	P/N: <b>220616108,</b>	3/bus,

### **Necessary tools:**

Regular hand tools, drill, 13/32" drill bit

## Birmingham: Coolant Recovery Tank Installation



### **SAFETY PRECAUTIONS MUST BE FOLLOWED ACCORDING TO ACCEPTED INDUSTRY STANDARDS AND LOCAL/PROPERTY REQUIREMENTS.**

1. Park the bus and apply parking brake.
2. Turn the battery disconnect switch to off position.
3. Open rear engine compartment door.
4. Turn engine run switch to middle position so bus can't be started accidentally.
5. Locate the small bracket at the street side of the engine cradle and cut it off. This bracket makes the access to the bolts difficult (see below).

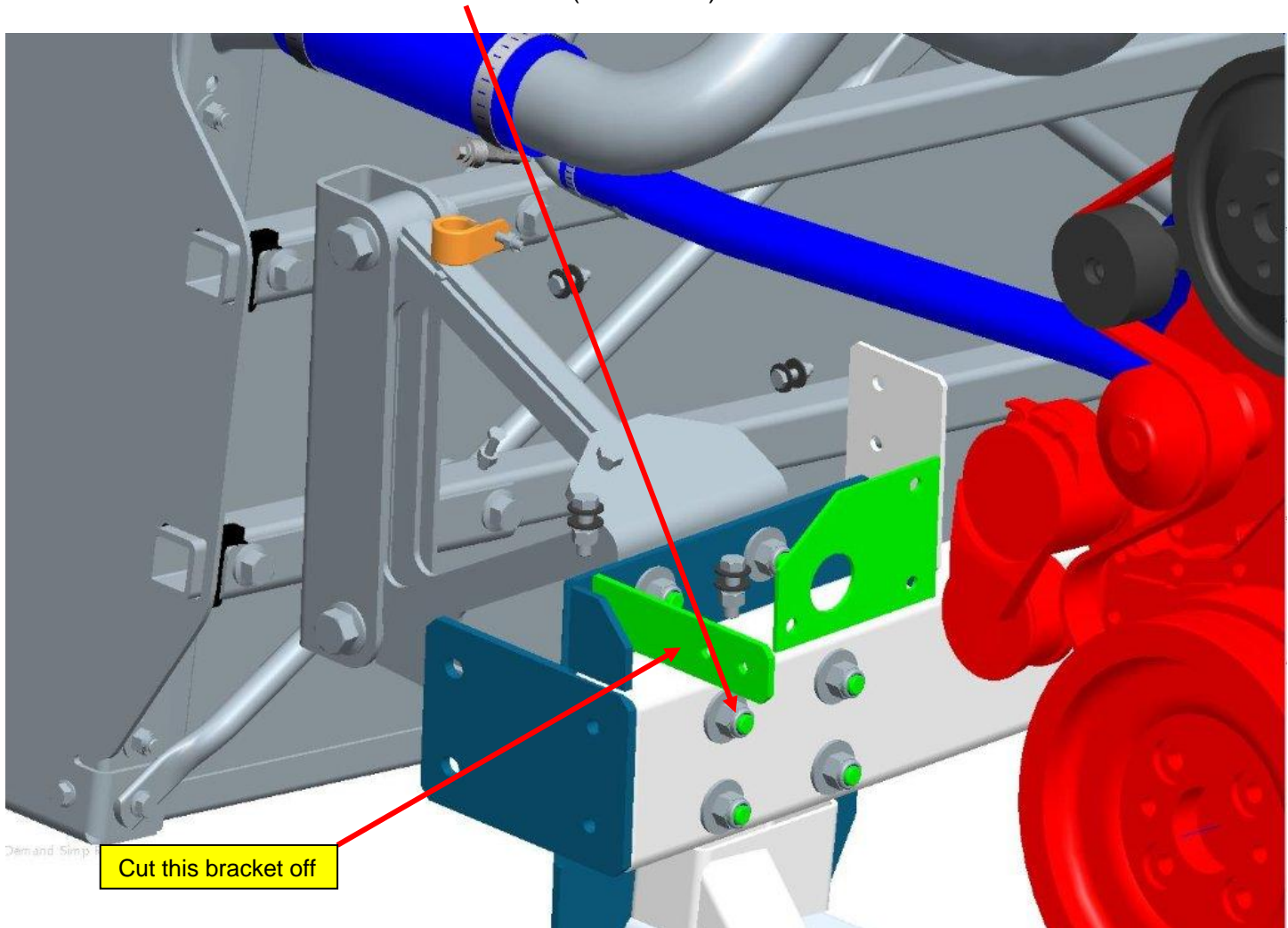

## Birmingham: Coolant Recovery Tank Installation



6. Install coolant recovery tank lower bracket (P/N 529-1315-001) using radiator bracket fasteners (see below). After the bracket is secured with the radiator bracket fasteners, match drill .405 diameter hole in radiator support bracket (see below). Secure bracket to the radiator support with 3/8 size bolt, washers and nut.

Secure coolant recovery bracket with this nut first

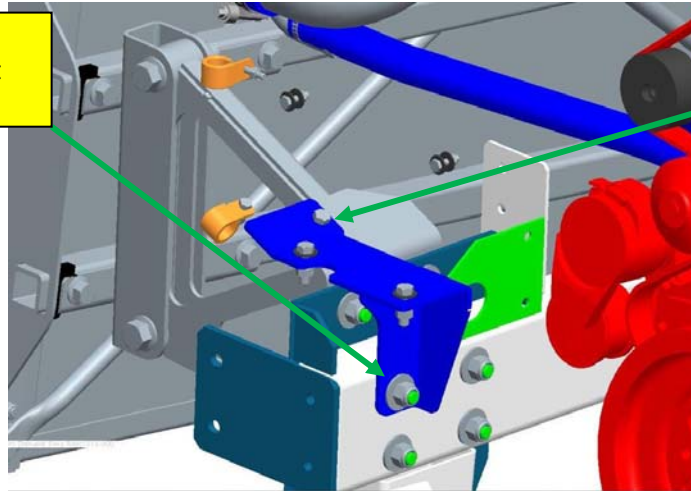

Then match drill .405 diameter hole in radiator support bracket here and install 3/8 size bolt, washers and nut

7. Install upper bracket first then install coolant recovery tank.

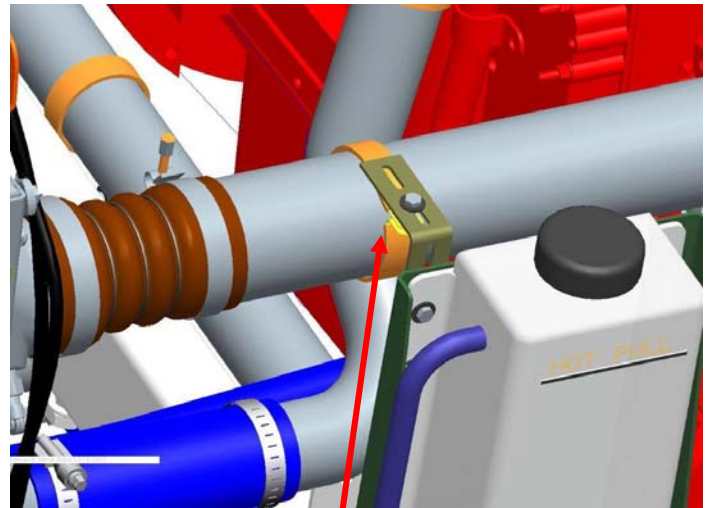
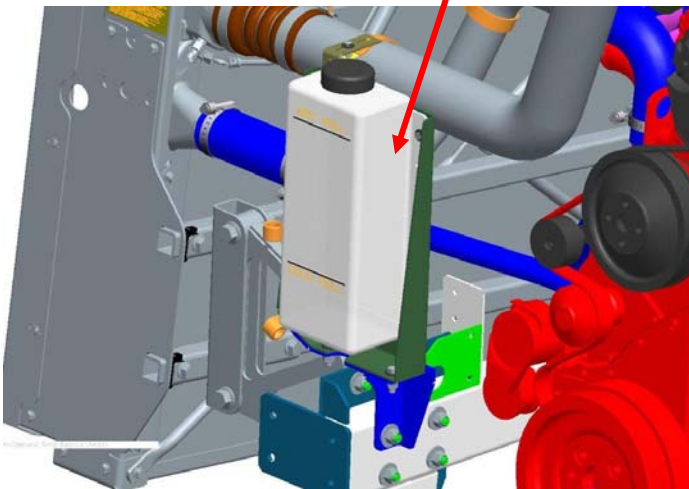

8. Install slotted bar to the back of the recovery tank bracket and hose clamp to the CAC pipe as picture show above. Use 1/4-20 bolt, washers and nut to secure the slotted bar to the clamp.

## Birmingham: Coolant Recovery Tank Installation



9. Install clamps and hoses per pictures below.

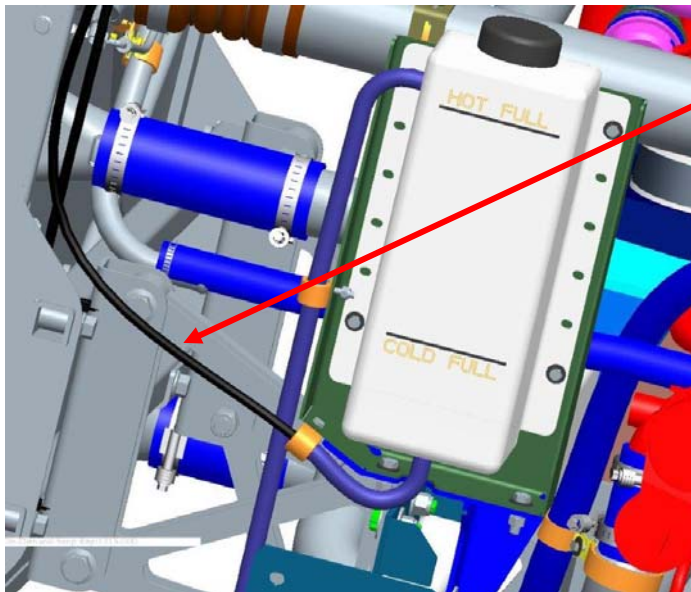

Hose from pressure cap

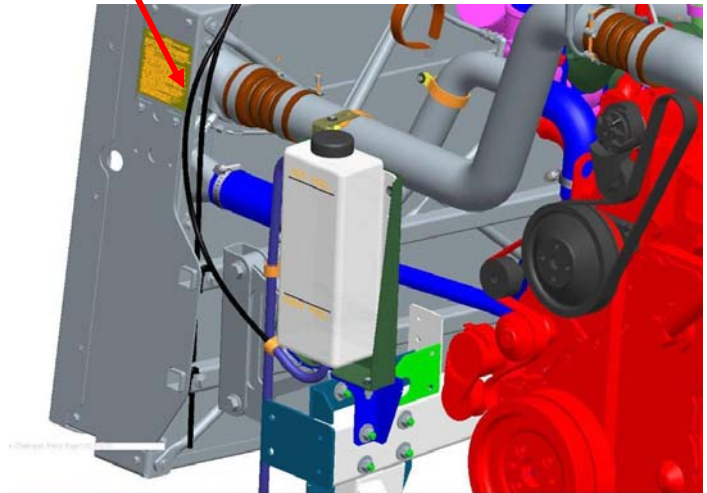

10. Remove unused parts and tools from work area.
11. Check for completeness of work.
12. Fill up the coolant recovery tank between the cold full and hot full level. Recheck the coolant level when the bus comes back from service next day and refill coolant recovery tank as required.
13. Turn the engine run switch to the "front run" position.
14. Turn on the battery disconnect switch.
15. Record bus number, mileage and date of completion.