



INSTRUCTION TO SERVICE

ITS: 5536	
SECTION:	219 Engine & Transmission
WRITTEN BY:	Mike Pearson
SUBJECT:	Replace exhaust flex connector.

ITS5536

THIS DOCUMENT AND THE CONTENTS DISCUSSED HEREIN ARE THE CONFIDENTIAL AND PROPRIETARY INFORMATION OF NEW FLYER INDUSTRIES CANADA ULC AND NEW FLYER OF AMERICA INC. AND ARE DISCLOSED BY NEW FLYER IN CONFIDENCE. THIS DOCUMENT AND THE CONTENTS HEREIN ARE NOT TO BE DISCLOSED BY THE INTENDED RECIPIENT WITHOUT THE PRIOR WRITTEN AUTHORIZATION OF NEW FLYER. ANY UNAUTHOIZED DISCLOSURE, REPRODUCTION OR OTHER DISTRIBUTION OF THIS DOCUMENT OR INFORMATION IS STRICTLY PROHIBITED AND MAY RESULT IN ACTION BEING TAKEN AGAINST THE PARTY MAKING THE UNAUTHORIZED DISCLOSURE. THIS DOCUMENT AND ALL COPIES HEREOF MUST BE RETURNED TO NEW FLYER UPON REQUEST.



NEW FLYER

The Cummins Exhaust Aftertreatment system requires preventative maintenance which is documented in the New Flyer Service Manuals and Cummins Manuals. Checking and maintaining proper exhaust flex connector alignment at intervals of every 6,000 miles (9,600 km) and inspection and cleaning of the Diesel Particulate Filter (DPF) at intervals of 200,000 miles (321,000 km) or 6,500 operating hours is required (whichever is less). In a Transit Bus application, the 6,500 operating hours typically occurs first.

Prematurely plugged DPFs have been found on some diesel or diesel-hybrid buses with Cummins 2010 ISL or ISB engines and Hutchinson exhaust flex connectors. Continued use of a bus with a restricted DPF can lead to frequent exhaust regenerations (occurring every 1 to 2 hours) often with Cummins Fault Code 2639 and 143 or 415. A plugged DPF can be caused by soot and ash and can be exacerbated by fibers from the Hutchinson flex connector getting into the exhaust stream.

To eliminate the flex connector insulation fibers as a contributor to plugged DPFs, New Flyer is releasing a proactive retrofit on all diesel and diesel-hybrid Cummins 2010 ISL or ISB engines to replace the Hutchinson exhaust flex connector with a stainless steel connector and a separate externally mounted insulation blanket. New Flyer will be providing an Instruction to Service (ITS), the required parts and one (1) hour labor to all affected customers. The campaign will be rolled out in a controlled manner and progressed based on parts availability.

Pre-2010 diesel and diesel-hybrid Cummins ISL or ISB engines are unaffected by this condition because the exhaust aftertreatment components are different (ie. no Selective Catalytic Reduction (SCR) installed after the DPF, Diesel Oxidation Catalyst (DOC) has a larger diameter in pre-2010 installations, pre-2010 installations did not have a diffuser before the DOC inlet, and the controls/operating parameters are different).

Post-2010 emissions systems for diesel and diesel-hybrid Cummins engines are unaffected because they have the above described stainless steel flex connector installed from production.

PROCEDURE:

1. Turn the main battery disconnect switch to the “OFF” position.
2. Open the rear engine access door.
3. Locate the exhaust flex connector. See Figure 1.

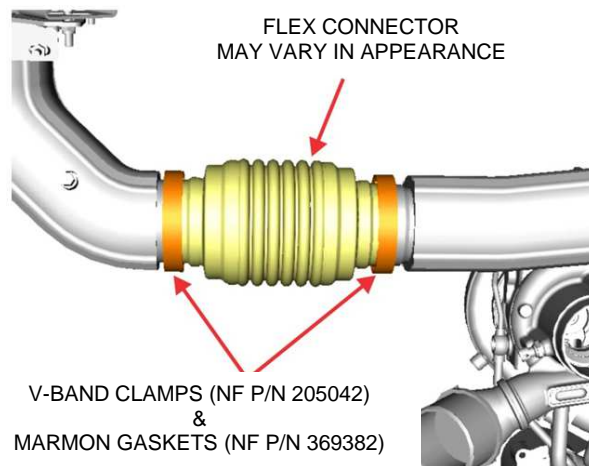

Figure 1: Exhaust Flex Connector

4. Loosen V-band clamps P/N 205042 and remove the flex connector. Save the existing clamps and Marmon gaskets for reuse but discard the existing flex connector (exhaust bellows).
5. Collapse alignment tool P/N 6360381 and position in between the exhaust tubes.
6. Rotate both ends of the alignment tool until it locks into the expanded position (locating pin should be out of the slot and in contact with edge of the slotted end of the tool). Make sure that the flanged end of the exhaust tubes are properly seated to the tool. See Figure 2.

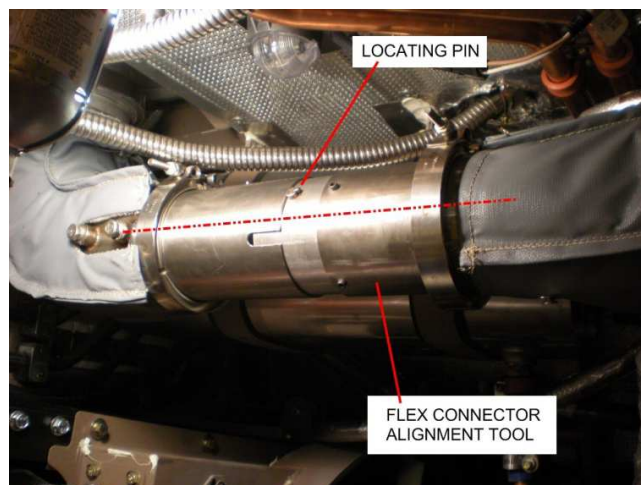

Figure 2: Flex Connector Alignment Tool



NEW FLYER

- ☞ **NOTE:** Adjustment of muffler and/or exhaust tubes might be necessary to achieve proper alignment. If the tool does not align or does not fit between the exhaust tube ends, loosen the following: upper muffler clamp and 3 lower muffler base bolts, muffler elbow V-band clamp, turbo to flex connector tube band clamp, exhaust tube U-bolt and turbo elbow V-band clamp (See Figure 3). Install the tool to exhaust tubes. Adjust and tighten the clamps to achieve proper alignment.

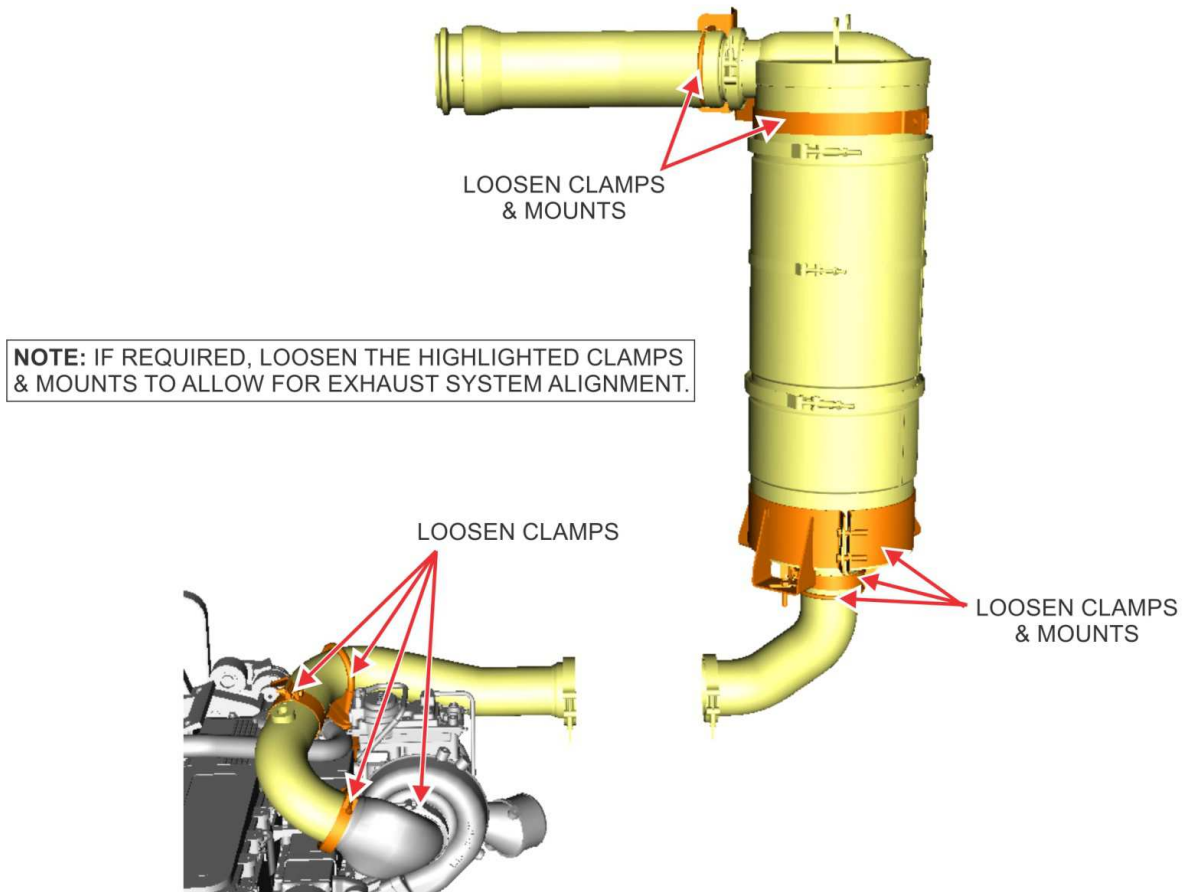

Figure 3: Exhaust Tube and Muffler Installation

7. Follow Appendix A to ensure that the exhaust tubes and exhaust flex connector alignment tool are all aligned.
8. After verifying that the tubes and tool are all aligned tighten the clamps to the following torque specifications:
 - a. Tighten the V-band clamp at the 90° outlet to turbo connection, torque to 124 in*lb (10 ft*lbs).
 - b. Tighten the V-band clamp at the exhaust tube to 90° turbo outlet connection, torque to 75 in*lb (6 ft*lbs).
 - c. If applicable, tighten the band clamp on the turbo to flex connector tube, torque to 45*60 ft-lb.
 - d. Tighten the U-clamp.
 - e. Tighten the V-band clamp on the muffler connection, torque to 75 in*lb (6 ft*lbs).
 - f. Tighten bolts on the muffler base if these were loosened.



NEW FLYER

9. Loosen V-band clamps on the exhaust flex connector alignment tool and slide them out of the way. Collapse the tool by rotating both ends and slipping the pin to the slot. Remove the tool.
10. Install the new exhaust flex connector p/n 495287 with existing Marmon gaskets. When installing a new exhaust flex connector, ensure that it is properly aligned as per Appendix A.

☞ **NOTE:** If existing V-band clamp(s) and/or Marmon gasket(s) are cracked or visible damaged they will need to be replaced.

☞ **NOTE:** Misaligned flex connector will lead to early failure. Make sure there is proper alignment when installed. See Appendix A – Flex Connector inspection. Periodic inspection is required.

11. Tighten the exhaust flex connector V-band clamps, torque to 75 in*lb.
12. Turn the main battery disconnect switch to the “ON” position.
13. Start the bus and check for exhaust leaks, adjust as needed.
14. After the flex connector installation has been completed cover the new connector with new insulation blanket p/n 6407715 and fasten using attached clasps, seam should be parallel and facing the rear of the bus, See Figure 4.



Figure 4: Insulated Blanket Installation

15. Close the rear engine access door.

APPENDIX A – Exhaust Flex Connector Alignment

⚠ WARNING: The exhaust flex connector is extremely sensitive to installation. A slight misalignment will result in premature failure. Careful inspection of the alignment is necessary.

👉 NOTE: Drawings and pictures shown may not exactly look like the actual parts on the bus. The illustrations are shown for visibility purposes.

MODES OF MISALIGNMENT

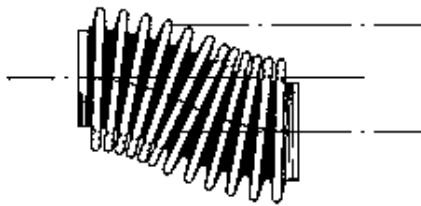

Lateral



Squirm

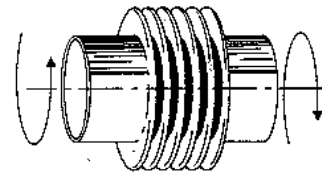

Torsional

Any combination of these conditions can lead to a dramatic reduction in component lifetime.

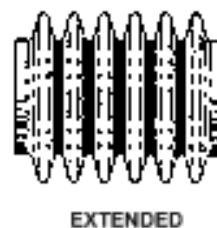

Axial

A correct installation will be straight. The exhaust flex connector will not be installed with torsion.

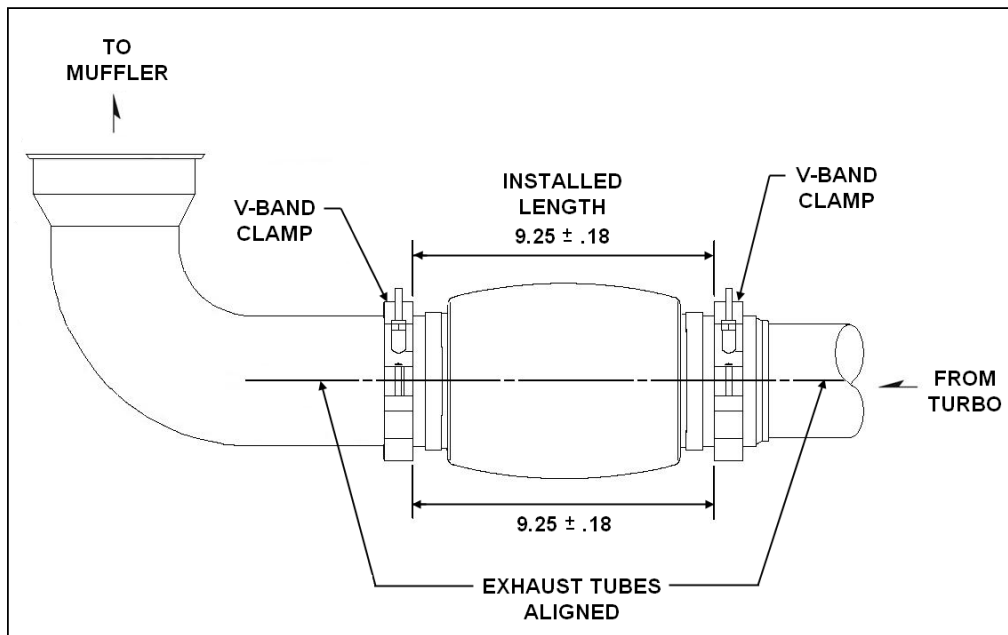

🔧 **NOTE:** Distance between torque clamp edges must be 9.25" +/- .18. Adjust exhaust tubes to achieve this distance (Free Length).

INSPECTING FOR MISALIGNMENT

You must inspect the flex connector from two different viewpoints. ***If the bend or offset is in the same plane as your eyes, you will not see it.*** Be sure the two viewpoints are approximately 90° different, such as viewing from above, and below, as shown in the following diagram.

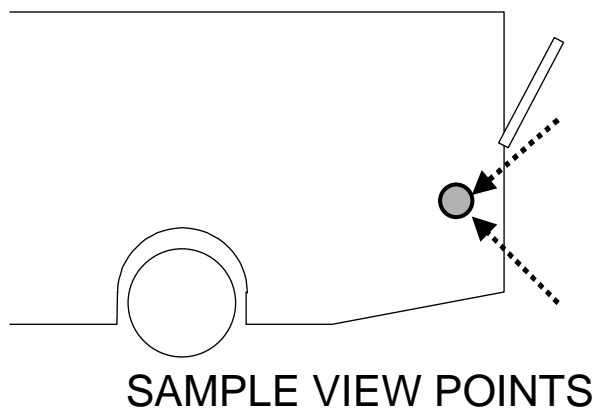



NEW FLYER

LABOUR ESTIMATE

	Operation	Men	Hours	Labour Time M X HR
1	Remove & replace exhaust flex connector.	1	1.0	1.0

PARTS REQUIRED

Item	Part Number	Description	Qty. per Coach	Units	Notes
1	495287	BELLOW-EXHAUST DURA FLEX BRAIDED	1	EA	
2	205042	CLAMP-EXHAUST V-BAND 4.75"	2	EA	Replace if required.
3	6407715	BLANKET-EXHAUST FLEX CONNECTOR	1	EA	Replace if required.
4	369382	GASKET-MARMON 4" STD	2	EA	Replace if required.

SPECIAL TOOLS REQUIRED

Item	Part Number	Description	Qty.	Units	Notes
1	6360381	TOOL, FLEX CONNECTOR ALIGNMENT	1	EA	