



INSTRUCTION TO SERVICE

ITS: 5100	
SECTION:	219 Engine and Transmission
WRITTEN BY:	Shaun Cardinal
SUBJECT:	MONO Inverter Conversion

ITS5100

THIS DOCUMENT AND THE CONTENTS DISCUSSED HEREIN ARE THE CONFIDENTIAL AND PROPRIETARY INFORMATION OF NEW FLYER INDUSTRIES CANADA ULC AND NEW FLYER OF AMERICA INC. AND ARE DISCLOSED BY NEW FLYER IN CONFIDENCE. THIS DOCUMENT AND THE CONTENTS HEREIN ARE NOT TO BE DISCLOSED BY THE INTENDED RECIPIENT WITHOUT THE PRIOR WRITTEN AUTHORIZATION OF NEW FLYER. ANY UNAUTHOIZED DISCLOSURE, REPRODUCTION OR OTHER DISTRIBUTION OF THIS DOCUMENT OR INFORMATION IS STRICTLY PROHIBITED AND MAY RESULT IN ACTION BEING TAKEN AGAINST THE PARTY MAKING THE UNAUTHORIZED DISCLOSURE. THIS DOCUMENT AND ALL COPIES HEREOF MUST BE RETURNED TO NEW FLYER UPON REQUEST.



PROCEDURE:

1. Turn the main battery disconnect switch to the "OFF" position.

⚠ WARNING: ALWAYS discharge the Ultra Capacitors before performing high voltage system maintenance on this vehicle. Refer to Section 5 of the Service Manual under 2.17 *Discharging the Ultra Capacitors* for the discharge procedure.

2. Orientation and Terms

- a. Components in this document will be referred to as "old" and "new". The meaning of each term will be as follows:
 - "old" : items removed from the vehicle
 - "new" : items provided by the ITS bill of material
- b. Refer to Fig 1 for bus orientation.

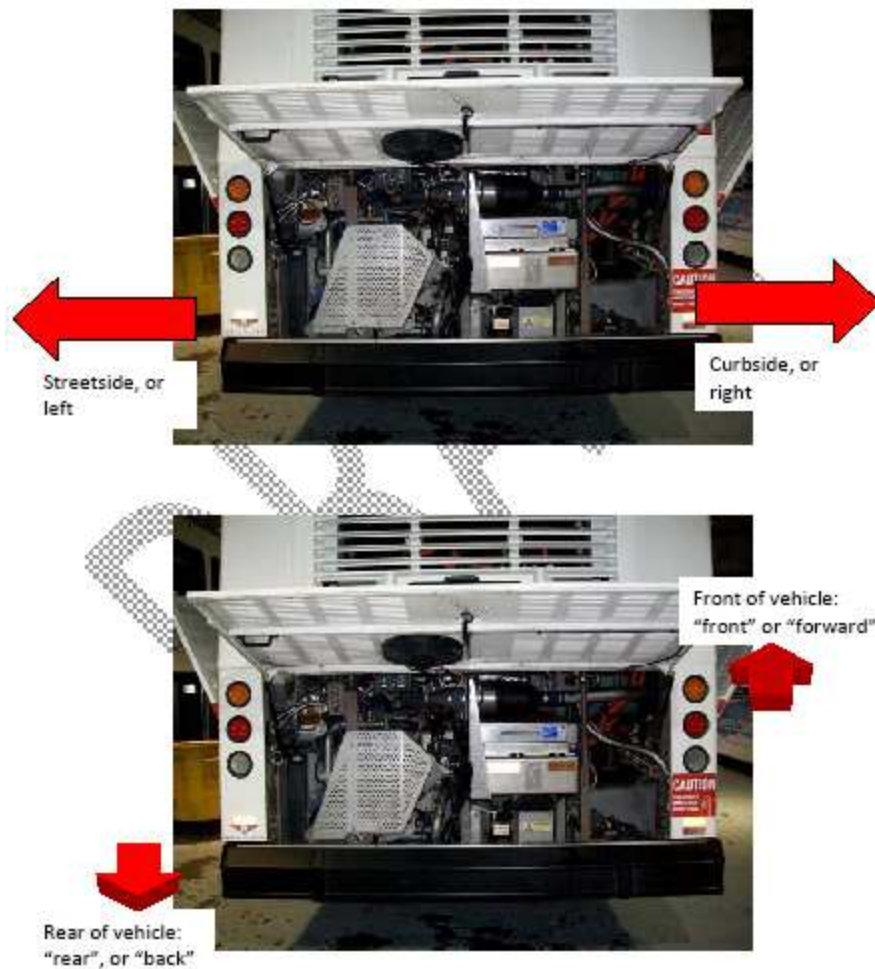

Figure 1: Orientation



NEW FLYER

3. Set Up

- a. For ease of installation, safely raise bus up only using approved lifting devices, following the approved Lifting instructions found in the service manual under the General Information section. Ensure safety stands are in place under approved jacking areas of the bus.

⚠ WARNING: Refer to *General Information of the Service Manual under Raising the Vehicle* for the approved lifting procedures and locations.

- b. Disconnect the oil gauge line; ensure a container is placed to keep the residual oil from spilling onto the floor. Using a separate clean container, drain all the coolant from the engine by opening the drain valves on the brake resistors. Close drain valves once coolant is drained. Ensure the oil does not mix into the coolant if there are plans to re-use. See Fig 2.

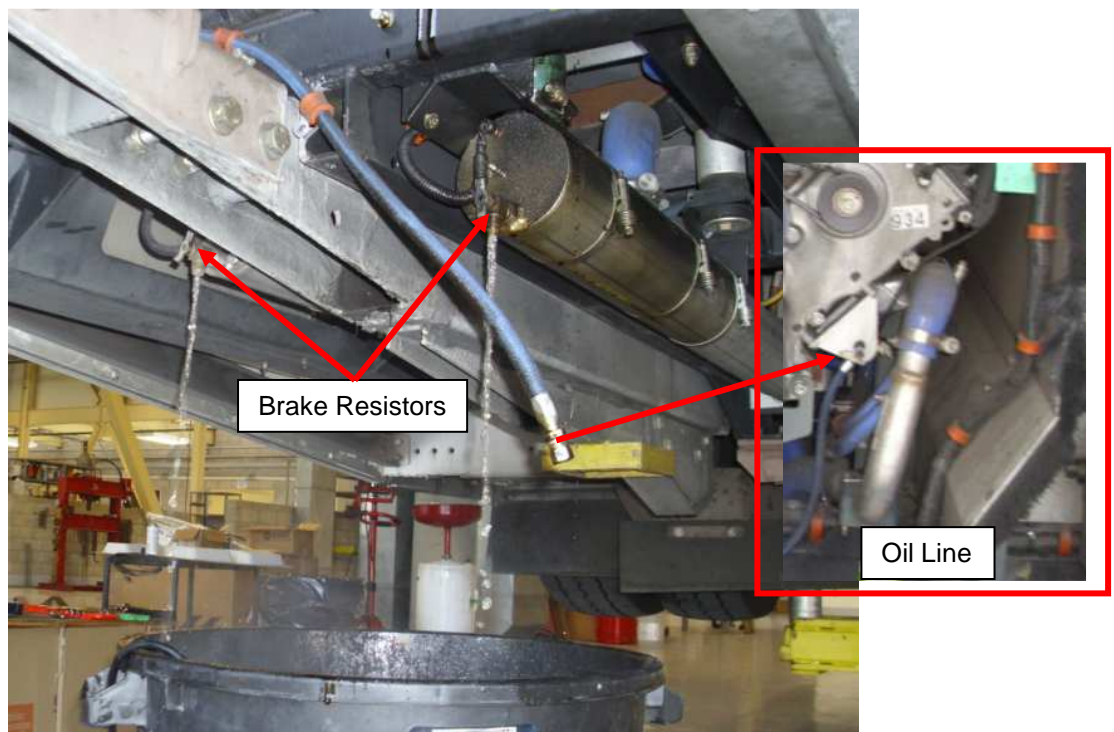

Figure 2: Draining Coolant and Oil Line Removal

- c. Remove the belt guard by unclamping main clamp and sliding guard up. See Fig 3.

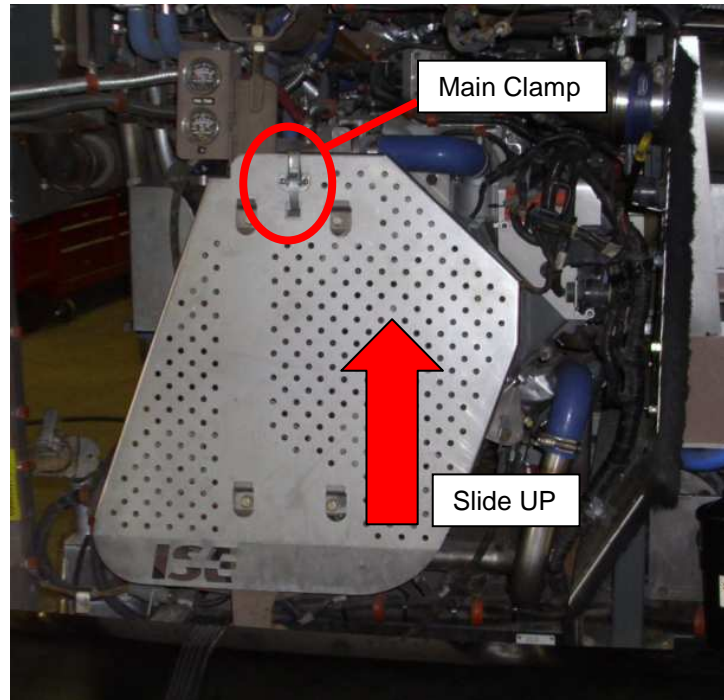

Figure 3: Belt Guard Reference

- d. Remove the Street Side (SS) engine strut assembly by unscrewing the top and bottom hardware securing it to the chassis. Secure the assembly out of the way. See Fig 4.

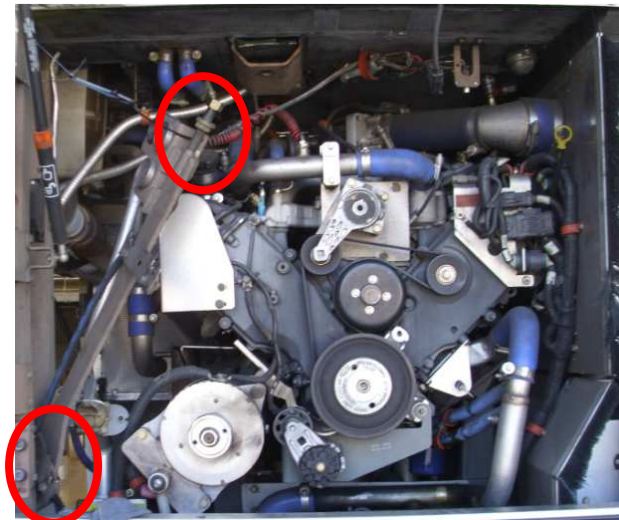

Figure 4: SS Engine Strut Removal



NEW FLYER

- e. Remove the old alternator mount assembly by unbolting the support rod and plate that holds the alternator in place. See Fig 5

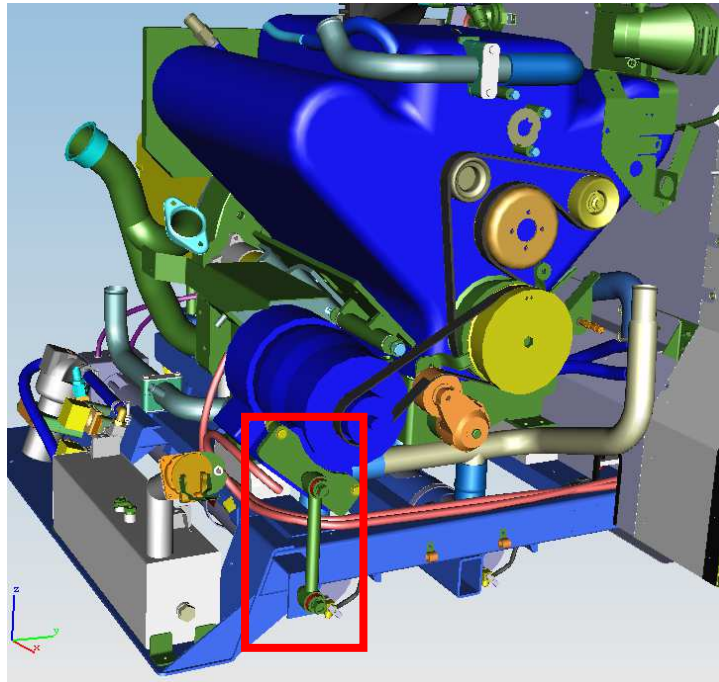

Figure 5: Alternator Reference

4. Engine Mount

- a. Disconnect O2 Sensors, loosen the exhaust Y-Pipe exhaust connections, and remove Y-Pipe. Fig 6

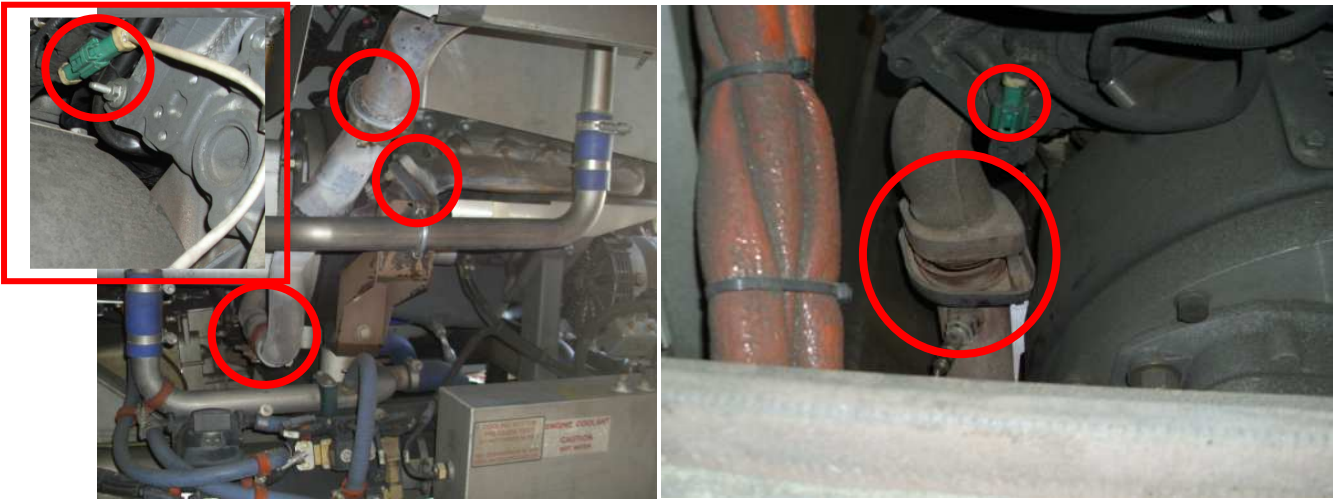

Figure 6: CS/SS Y-Pipe Connections

- b. Disconnect coolant hoses and remove Brake Resistor coolant tube. Fig 7

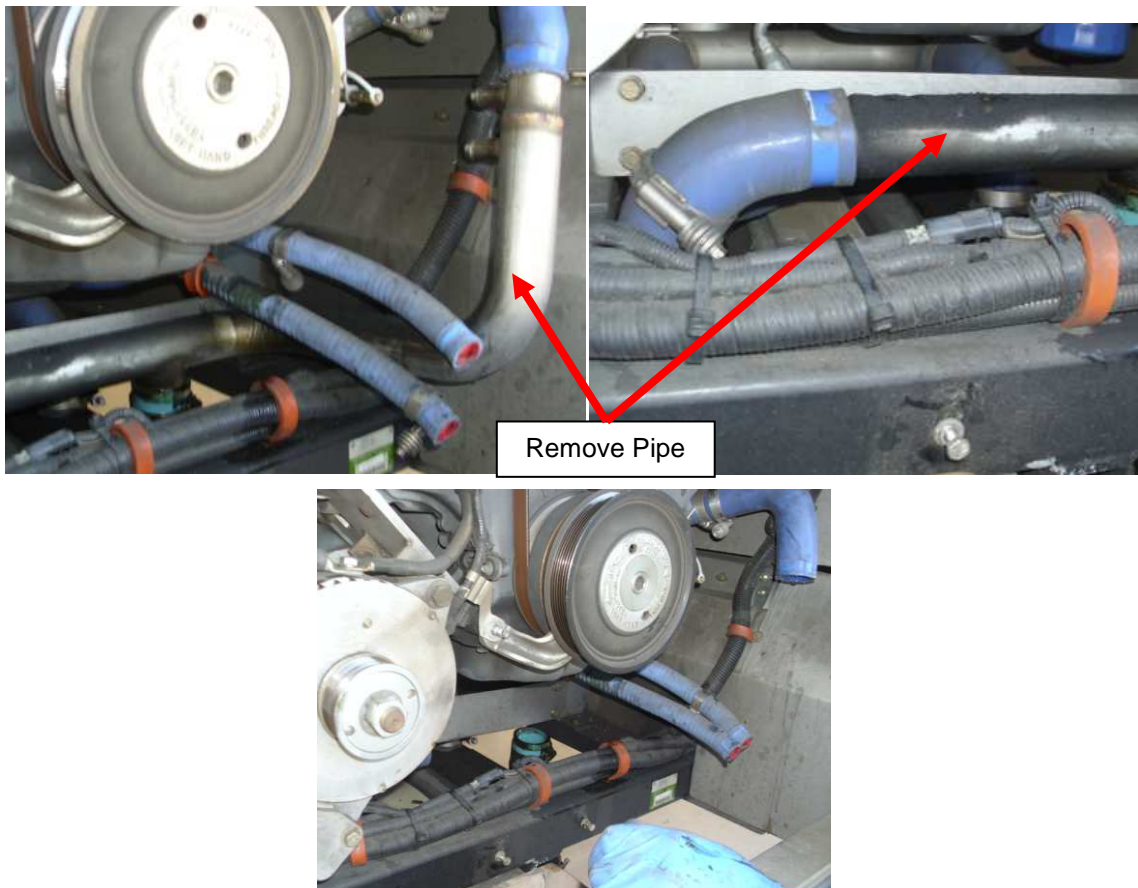

Figure 7: Brake Resistor Coolant Tube Removal

- c. Remove CS engine CAN connectors by the divider plate. Fig 8



Figure 8: CS Engine CAN Connector

- d. Disconnect throttle body intake tube. Fig 9



Figure 9: Throttle Body Air Intake Tube

- e. Disconnect engine starter harness. Fig 10



Figure 10: Starter harness

- f. Remove rear generator mount by disconnecting connection point to the generator, support the generator using a bottle jack. Fig 11



Figure 11: Generator Mount Support



NEW FLYER

- g. Remove the generator mount assembly by removing eyelet, the jam nut holding the spring in place, the spring assembly, followed by the hardware securing the assembly to the engine cradle. See Fig 12.



Figure 12: Generator Mount Assembly

- h. Remove center engine brace. Fig 13.



Figure 13: Front Engine Center Brace

- i. Loosen hardware securing the front engine mounts to the engine and cradle (CS and SS). Fig 14



Figure 14: Front Engine Center Brace

- j. Remove the nuts holding the bell housing spacers in place. Seized hardware may require cutting to remove. Upon removal of the top nut, slowly lift up the generator (using the bottle jack) to gain access between the spacer and cradle (ensure the oil dipstick is free from any obstructions). Cut the bolt in the middle to allow removal of spacer (do not discard spacer as it will be used as a temporary stand for the generator install). See Fig 15.



Figure 15: Bell Housing Spacer Removal



NEW FLYER

- k. Using a bottle jack, support the engine by placing the jack between the CS or SS of the engine block casting tabs and front engine cradle structure. Remove P-Clamps holding the harness to the rail to allow room for bottle jack. See Fig 16.



Figure 16: Bell Housing Spacer Removal/Engine Tabs

- l. Remove the hardware securing the CS engine mount to the cradle and engine and remove the mount. See Fig 17.



Figure 17: CS Mount Removal



NEW FLYER

- m. Using the CS engine rail drill jig (Blue Jig # LF-DJ-2025), locate per Fig 18 and drill through the entire plate using a $\frac{1}{4}$ " diameter drill bit. Using the new $\frac{1}{4}$ " hole as a guide, open the two new holes to $\frac{9}{16}$ " (0.5625").



Figure 18: CS Mount Drilling



NEW FLYER

- n. Secure the new CS Engine Mount (**NFI PN 483085**) to engine cradle using two ½ UNC lock nuts **NFI PN 40N08000**, four ½" flat hardened washers **NFI PN 20W08000**, two ½" UNC bolts (1.75" long) **NFI PN 10B06064**, three 3/8" UNC bolts **NFI PN 10B06020**, six 3/8" flat hardened **NFI PN 20W06000** washers, three 3/8-16 Lock Nut **NFI PN 40N06000**, two M12x1.5 nuts (**NFI PN 492408**), and two ½" flat hardened washers **NFI PN 20W08000**. Leave hardware loose as it allows the engine to tilt for easier generator mount installation. Use Never Seize **NFI PN 5928660**. See Fig 19.

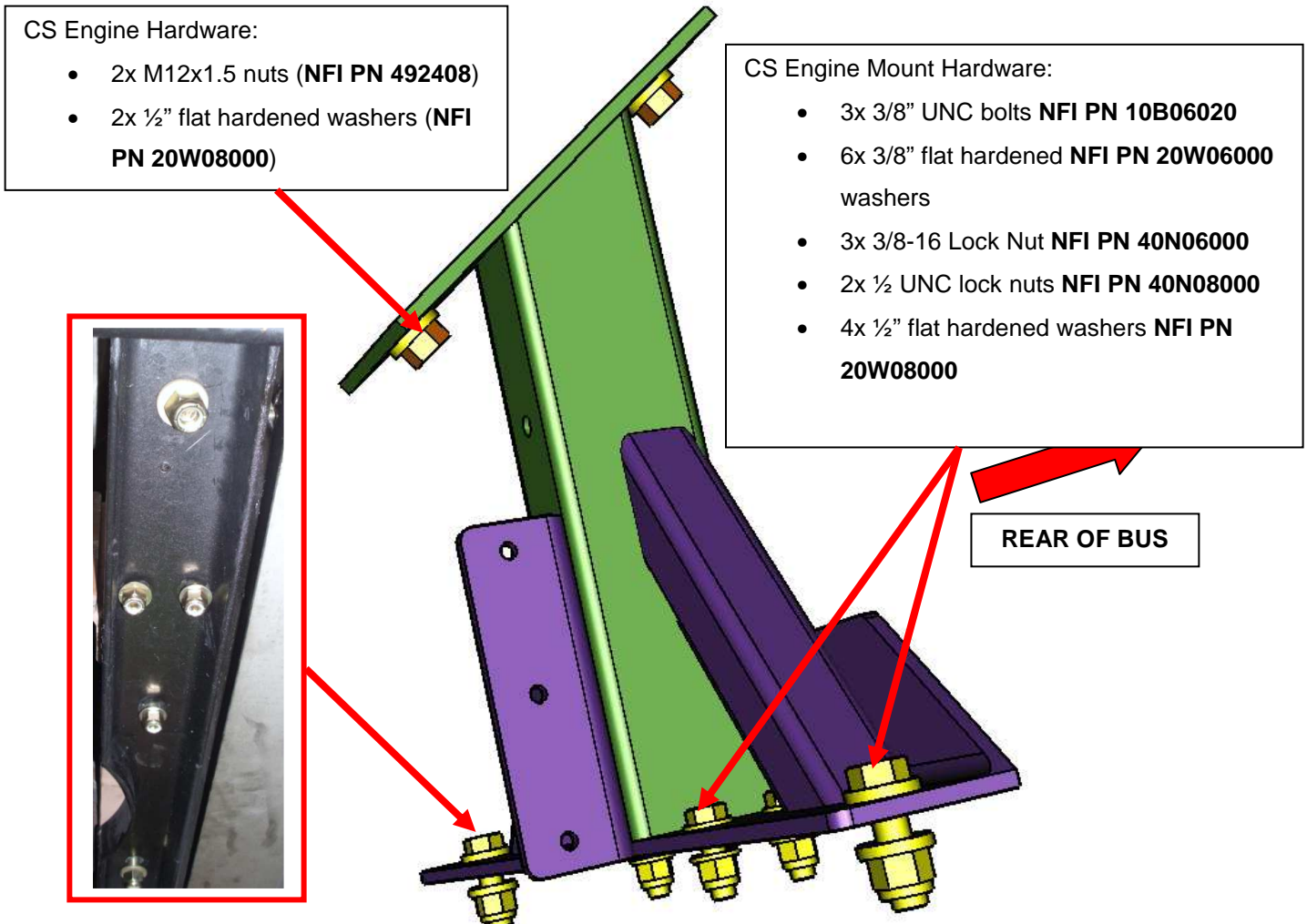

Figure 19: New CS Engine Mount



NEW FLYER

- o. Remove the hardware securing the SS engine mount to the cradle and engine and remove the mount (similar to the CS).
- p. Using the SS engine rail drill jig (Blue Jig # LF-DJ-2026), locate per Fig 20 and drill through the entire plate using a $\frac{1}{4}$ " diameter drill bit. Using the new $\frac{1}{4}$ " hole as a guide, open the two new holes to $\frac{9}{16}$ " (0.5625").



Figure 20: SS Mount Drilling



NEW FLYER

- q. Secure the new SS Engine Mount (**NFI PN 483081**) to the engine cradle using two ½ UNC lock nuts **NFI PN 40N08000**, four ½" flat hardened washers **NFI PN 20W08000**, two ½" UNC bolts (1.75" long) **NFI PN 10B06064**, three 3/8" UNC bolts **NFI PN 10B06020**, six 3/8" flat hardened **NFI PN 20W06000** washers, and three 3/8-16 Lock Nut **NFI PN 40N06000**, two M12x1.5 nuts (**NFI PN 492408**), and two ½" flat hardened washers **NFI PN 20W08000**. Leave hardware loose as it allows the engine to tilt for easier generator mount installation. Use Never Seize **NFI PN 5928660**. See Fig 21.

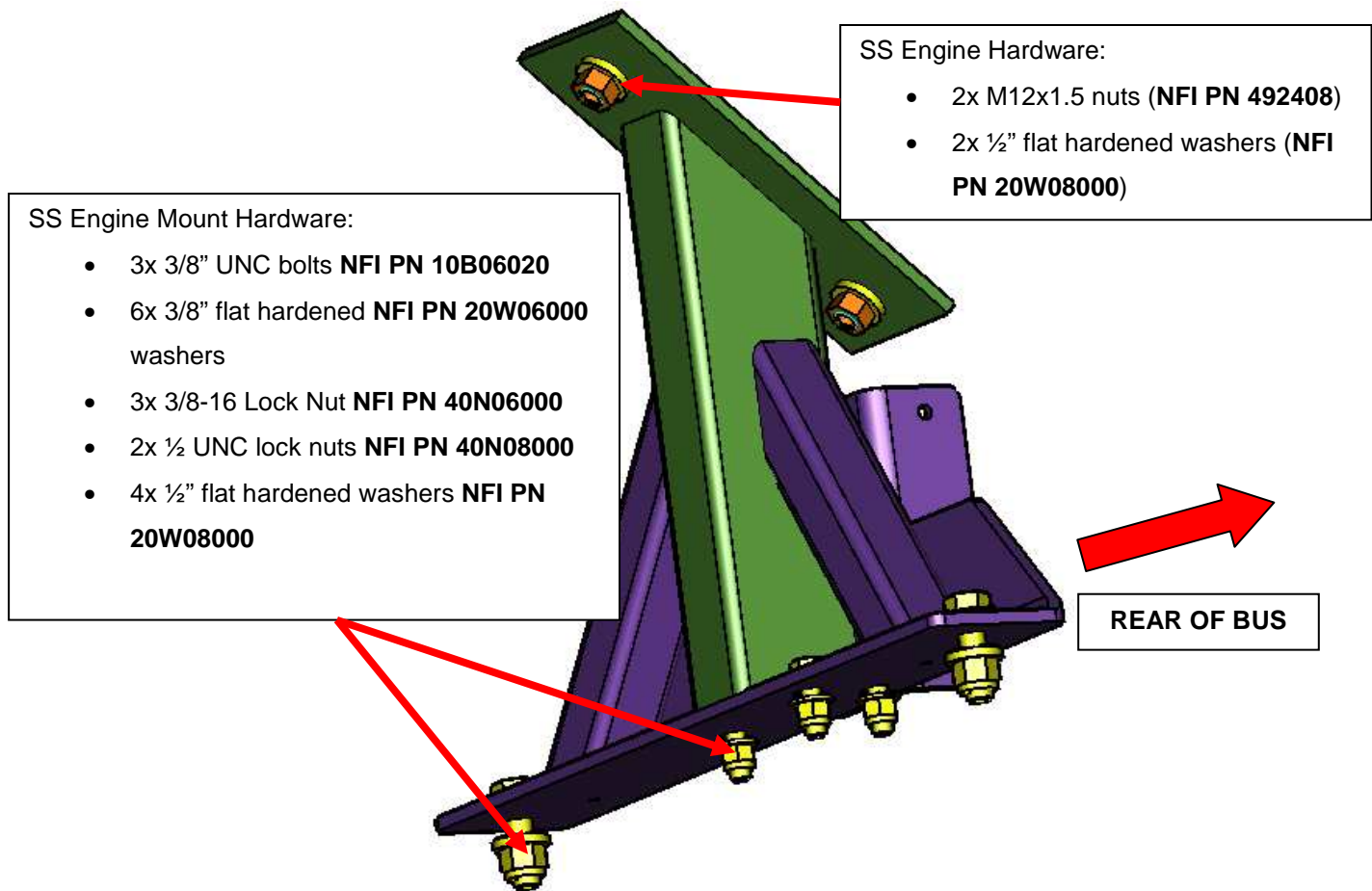

Figure 21: New SS Engine Mount



NEW FLYER

- r. Install the lateral engine brace (**NFI PN 484008**) between the new engine mounts using six 5/16" Lock Nut (**NFI PN 40N05000**), twelve 5/16" hardened flat washers (**NFI PN 20W05000**), and six 5/16" UNC bolts 1.25" long (**NFI PN 10B05020**). Leave hardware loose to allow ease of generator mount install. Use Never Seize **NFI PN 5928660**. See Fig 22.

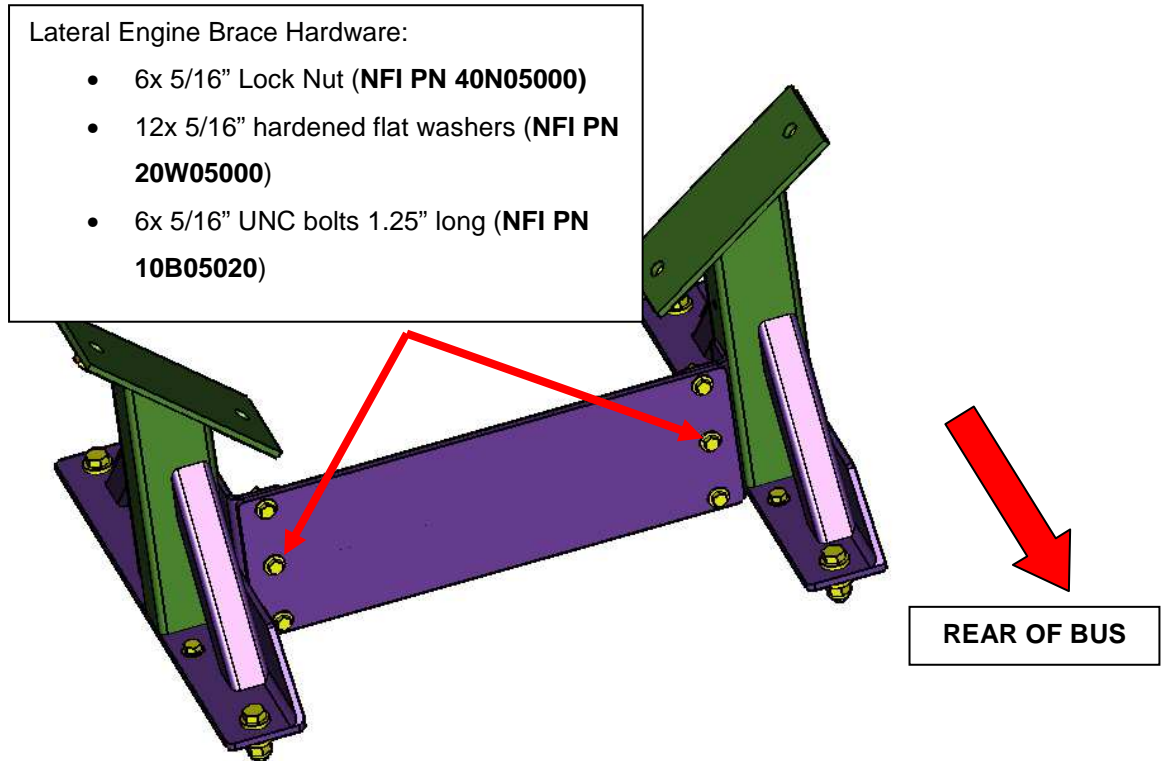

Figure 22: Lateral Engine Brace

5. Generator Mount

- a. Remove the 3 ground cables located on the engine cradle, under the generator. See Fig 23.

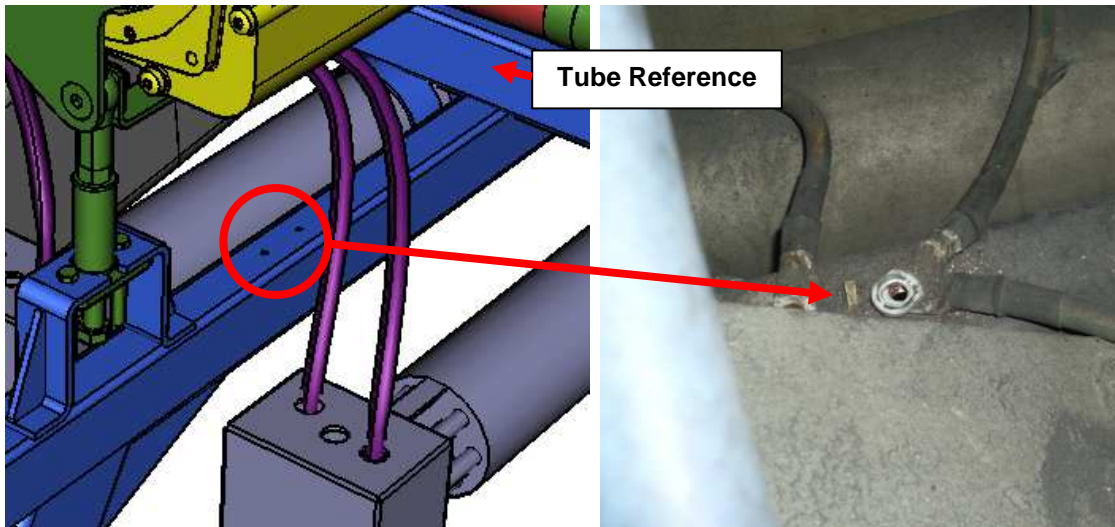

Figure 23: Ground Cables

- b. Using the generator mount drill jig (Blue Jig # LF-DJ-2027), locate per Fig 24 (ensure jig stop is against tube reference) and drill through the entire tube using a 1/4" diameter drill bit. Using the new 1/4" holes as a guide, open the tube holes to 7/16" (0.4375").

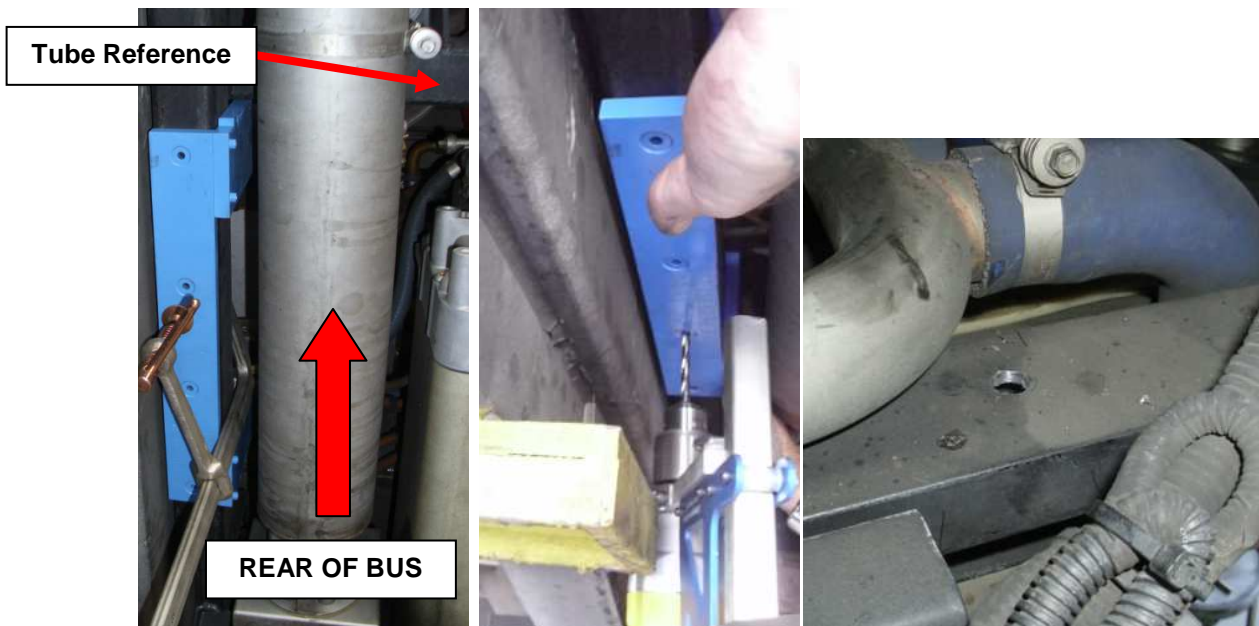

Figure 24: Generator Mount Drilling



NEW FLYER

- c. Place the spacers removed in section 5j between the bell housing and cradle as a temporary stand. Slowly lower and remove the bottle jack holding the generator in place. Ensure the hardware securing the engine block to the engine mounts (section 5) is left loose as this will allow the generator to tilt down. See Fig 25.



Figure 25: Temporary Stand for Engine and Cradle

- d. Install the generator support (NFI PN 477527) to the generator, securing with two M10x1.5 bolts 40mm long (NFI PN 024679). See Fig 26.



Figure 26: Assembled generator support assembly



NEW FLYER

- e. Sub-assemble generator isolator (**NFI PN 477289**) to generator mount frame NFI PN 477655 using two M12x1.5 nuts (**NFI PN 492408**) and two ½” hardened flat washers (**NFI PN 20W08000**). Ensure the REAR stamping on the isolator faces the REAR of the generator. Use Loctite-242 **NFI PN 8110440**. See Fig 27.

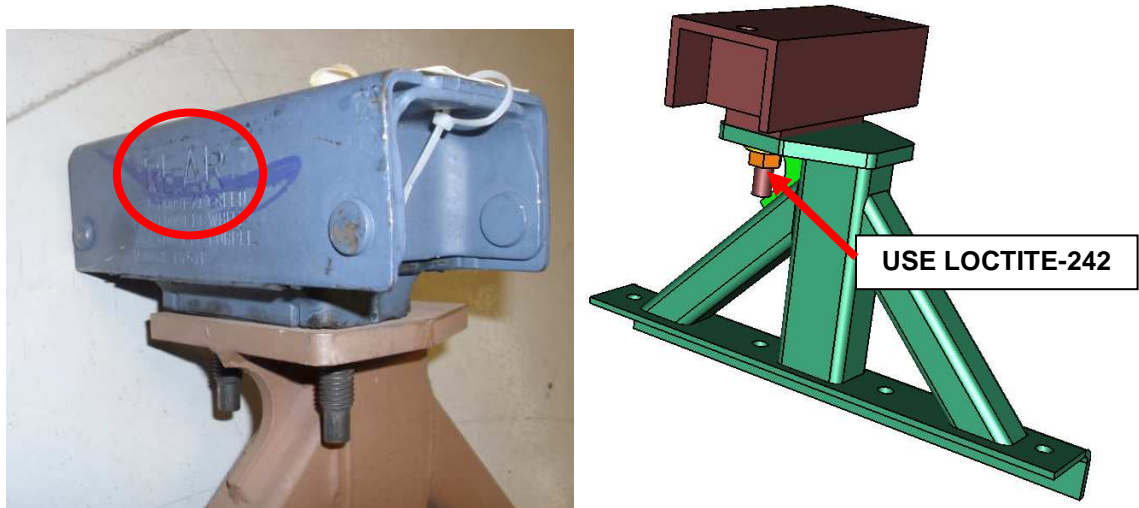

Figure 27: Assembled generator mount assembly

- f. Using a bottle jack between the generator and engine cradle frame, lift the generator up and remove the spacers in Fig 25 (discard as they are no longer used) to allow the generator mount assembly (Fig 27) to be installed between the generator support and engine cradle. Secure assembly with two 7/16 bolts **NFI PN 10B07020**, four 7/16 flat washers **NFI PN 10W07000**, and two 7/16 lock nuts **NFI PN 40N07000**. Use Never Seize **NFI PN 5928660** for all connections. See Fig 28

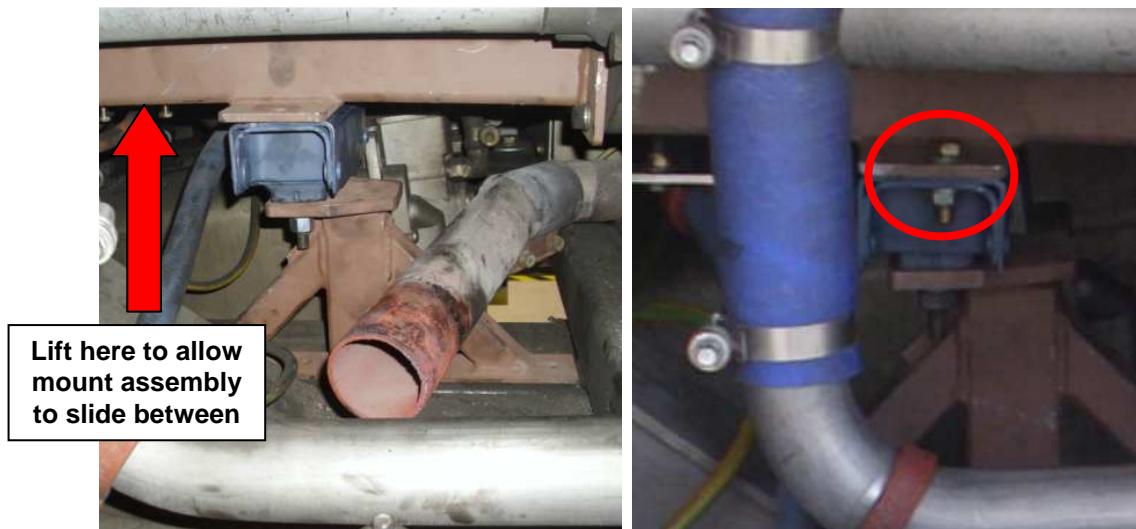

Figure 28: Generator mount assembly



NEW FLYER

- g. Secure with four 3/8 UNC x 4.00" long bolts (**NFI PN 10B06064**), eight 3/8" hardened flat washers (**NFI PN 20W06000**), and four 3/8" UNC Lock Nuts (**NFI PN 40N06000**). Use Never Seize **NFI PN 5928660**. See Fig 29.



Figure 29: Generator mount hardware

6. Alternator Mount

- a. Install the new alternator mount assembly to the alternator. Ensure new spacers **NFI PN 484505** are placed behind bracket **NFI PN 482693** and torque hardware to 22 ft-lb. Use Never Seize **NFI PN 5928660**. See Fig's 30 and 31



Alternator Bracket **NFI PN 482693**

Figure 30: New Alternator Bracket

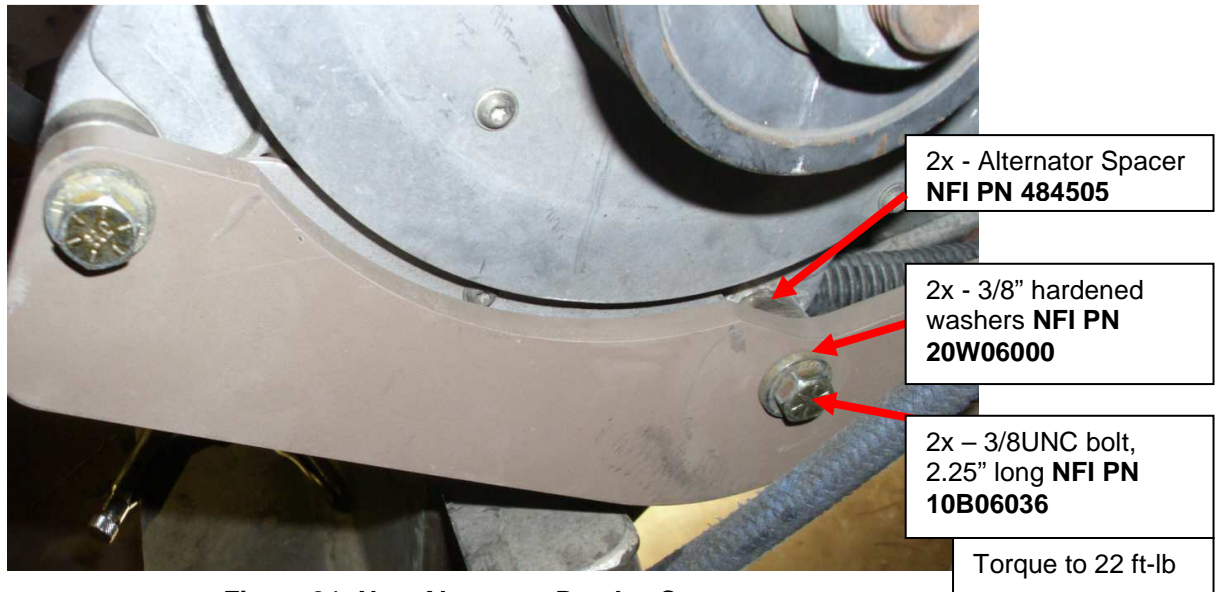

Figure 31: New Alternator Bracket Spacers

- b. Using the bracket as a template, drill a 9/16" diameter hole at the location shown in Fig 32. Install **NFI PN 20W08000**, **10B08028**, and **40N08000** per Fig 33 and torque to 53 ft-lb. Use Never Seize **NFI PN 5928660**.

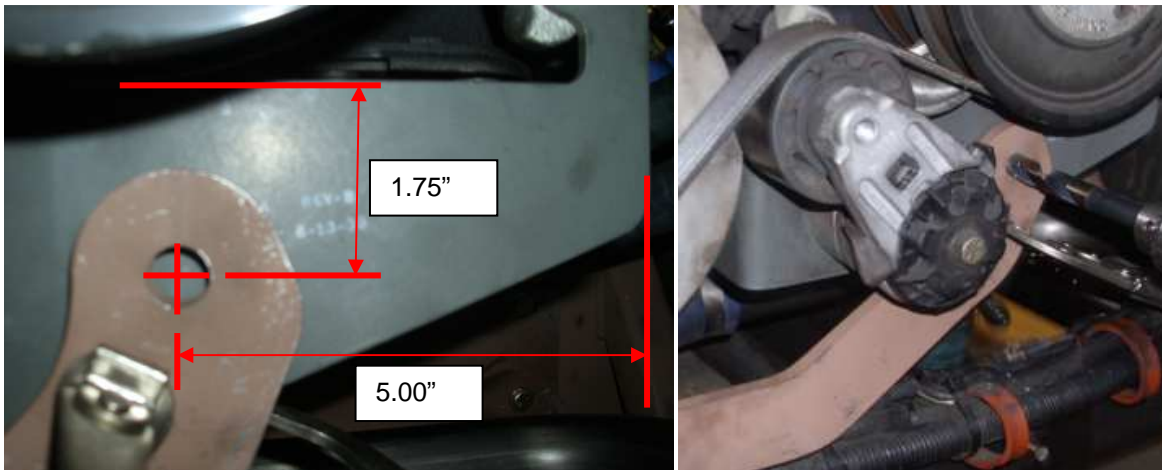

Figure 32: New Alternator Bracket Mounting

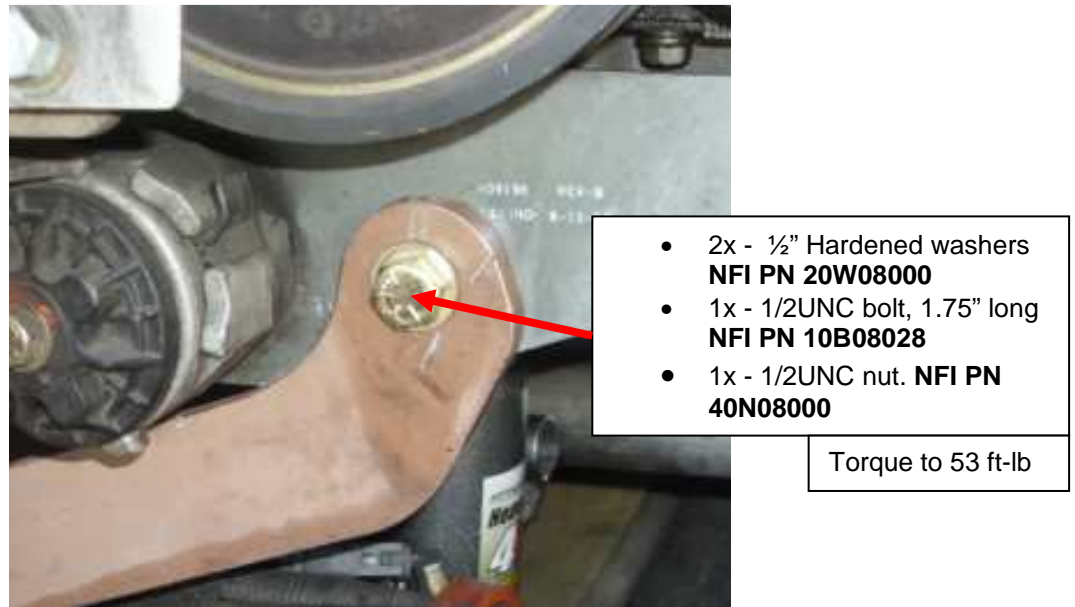

Figure 33: New Alternator Bracket Hardware

7. Final Assembly

- a. Torque all hardware and use Loctite-242 NFI PN 8110440 per Fig 34.

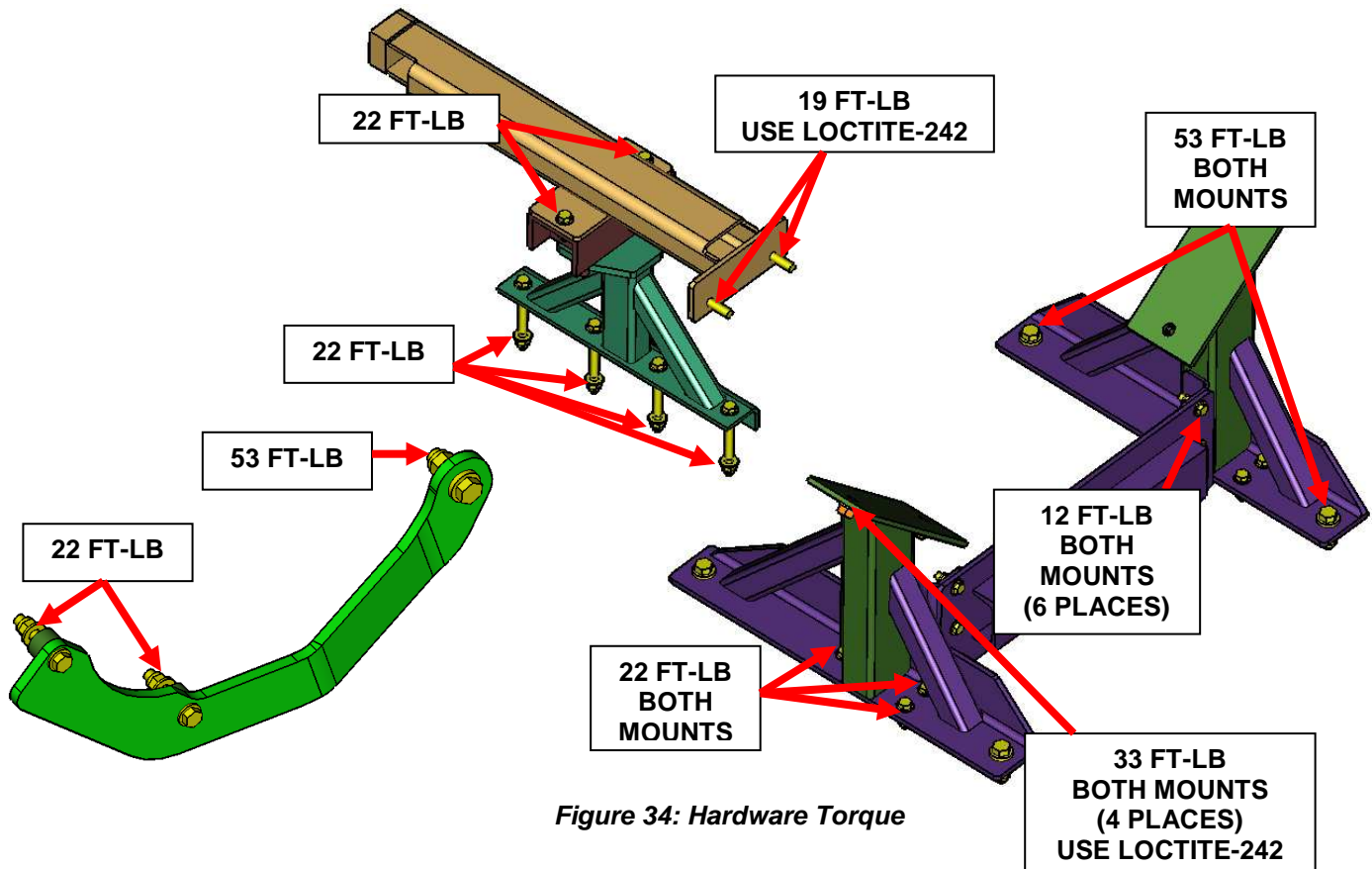

Figure 34: Hardware Torque



NEW FLYER

- b. Secure high voltage cables and hose to generator support assembly. Ensure none of the lines rub on structure or other components. See Fig 35



Figure 35: Cable support

- c. Relocate the 3 ground wires to the old generator mounting bracket (on the engine cradle). Ensure a good ground connection by cleaning any dirt and paint off the cradle before re-using the old hardware to secure the wires. See Fig 36.



Figure 36: Grounds



NEW FLYER

- d. Re-install the Y-Pipe assembly by reversing the steps found in 5a. See Fig 37.

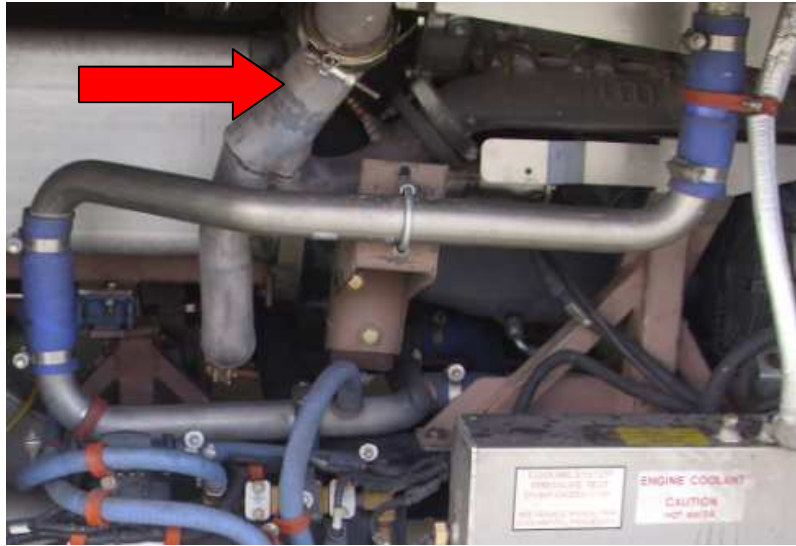

Figure 37: Installed Mounts

- e. Re-install the Brake Resistor Coolant Tube assembly by reversing the steps found in 5b. See Fig 38.



Figure 38: Installed Coolant Tube

- f. Re-install the CAN connectors on the CS divider panel by reversing the steps found in 5c. See Fig 39.

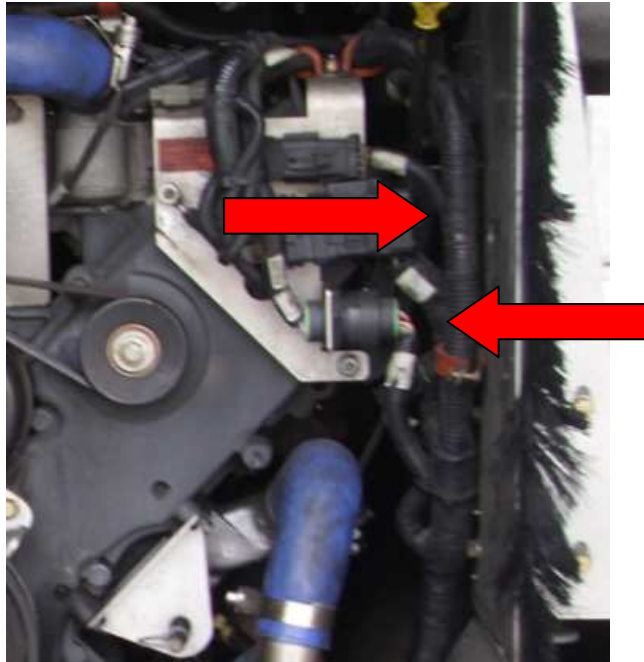

Figure 39: Installed CAN Connectors

- g. Re-install the Engine Air Intake Tube by reversing the steps found in 5d. See Fig 40.



Figure 40: Installed Air Intake

- h. Re-install the Engine Starter Harness by reversing the steps found in 5e. See Fig 41.



Figure 41: Starter Harness

- i. Re-install the SS engine strut assembly and connect the oil pressure line back to the engine block routing the line per Fig 42 to ensure no rubbing against structure.

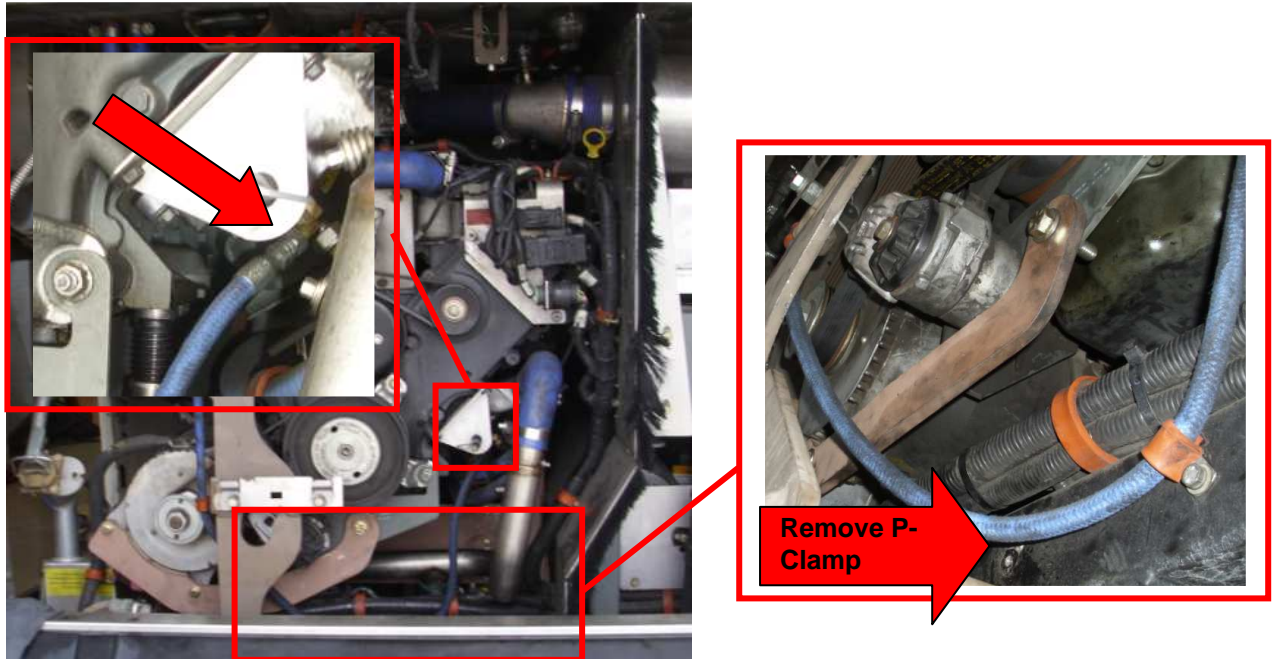

Figure 42: Engine Strut and Oil Line

- j. Re-install belt guard and secure. Fig 43.

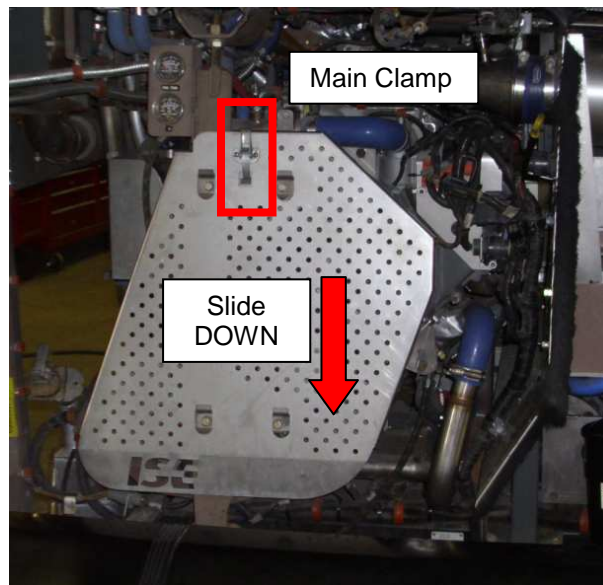

Figure 21: Belt Guard

- k. Refill the bus with coolant, following the Coolant Filling procedure found in **Cooling System Section 2.6** of the Service Manual.



NEW FLYER

LABOUR ESTIMATE

	Operation	Men	Hours	Labor Time M X HR
1	MONO Inverter Conversion	2	8.0	16.0

PARTS REQUIRED

Item	Part Number	Description	Qty. per Coach	Units	Notes
1	492408	NUT-M12X1.5	6	EA	
2	024679	BOLT-M10 X 1.5 X 40 CL10.9	2	EA	
3	10B05020	BOLT-HEX 5/16 UNC X 1.25	6	EA	
4	10B06020	BOLT-HEX 3/8 UNC X1.25	8	EA	
5	10B06036	BOLT-HEX 3/8 UNC X 2.25	2	EA	
6	10B06064	BOLT-HEX 3/8 UNC X 4.00	4	EA	
7	10B08028	BOLT-HEX 1/2 UNC X 1.75	5	EA	
8	10W07000	WASHER FLAT 7/16	6	EA	
9	20W05000	WASHER-HARDENED 5/16	12	EA	
10	20W06000	WASHER-FLAT HARDENED 3/8	28	EA	
11	20W08000	WASHER FLAT HARDENED 1/2"	16	EA	
12	40N05000	NUT LOCK NYLON 5/16"	6	EA	
13	40N06000	NUT-3/8-16 LOCK	14	EA	
14	40N08000	NUT-HEX LOCK 1/2 UNC	5	EA	
15	477289	MOUNT-ISE ISOLATOR	1	EA	
16	477527	ASSY-ISE GENERATOR MOUNT	1	EA	
17	477655	ASSY-ISE ENGINE MOUNT FRAME	1	EA	
18	482693	BRKT-ALTERNATOR ISE	1	EA	
19	483081	ASSY-ENGINE MOUNT SS	1	EA	
20	483085	ASSY-ENGINE MOUNT CS	1	EA	
21	484008	ASSY-LATERAL ENGINE BRACE	1	EA	
22	484505	SPACER-ALTERNATOR	2	EA	
23	5928660	NEVER SEIZE	.010	EA	
24	8110440	LOCTITE 242	.010	EA	
25	10B07020	BOLT-HEX 7/16 UNC 1.25	2	EA	
26	40N07000	NUT-7/16 LOCK	2	EA	



NEW FLYER

SPECIAL TOOLS REQUIRED

Item	Part Number	Description	Qty. per Coach	Units	Notes
1	LF-DJ-2025	CS Engine Mount Drill Jig	1	EA	Blue Tool
2	LF-DJ-2026	SS Engine Mount Drill Jig	1	EA	Blue Tool
3	LF-DJ-2027	Generator Mount Drill Jig	1	EA	Blue Tool