

REFERENCE:	Nova Bus Manuals
SECTION:	09 Engine and accessories
RS N°:	MQR 7621-273
EFFECTIVE IN PROD.:	L731 (2012DE)

APPLICATION DEADLINE:

-

SUBJECT:	Engine mount rubber isolators
JUSTIFICATION:	Rubber isolators with a new design are now available

LEVEL	DESCRIPTION	DIRECT CHARGES		TIME
		LABOUR	MATERIAL	
1	Change the engine mount rubber isolators	Client	Client	6h
2	-	-	-	-

MATERIAL

QTY	PART N°	REV.	DESCRIPTION	REPLACES PART N°
LEVEL 1				
2	N68290	A	Rubber mount	-
2	N69398	-	Shim	-
8	N56322	-	M10X50 bolt	-
4	N66492	A	Rubber mount	-
8	N31667	-	Locknut	-
8	Note 1	-	M16 Norlock washer	-
8	Note 1	-	Engine mount anchor bolt (flywheel housing)	-
LEVEL 2				
-	-	-	-	-

NOTE 1; Refer to the parts manual to order the anchor bolt and lockwasher that affix the engine mount to the engine flywheel housing.

Materials will be available within 56 days. To order, please contact Prevost Parts by phone at 1-800-771-6682, by fax at 1-888-668-2555 or by email at prevostparts.commandes@volvo.com. Specify document number, quantity of parts required and shipping address.

DISPOSAL OF PARTS

REMOVED PARTS ARE:	DISCARDED	RETAINED	-
	-	-	

REVISION HISTORY

REV.	DATE	CHANGE DESCRIPTION	WRITTEN BY
NR	2013MA05	Initial release	Wilder Galiano
R1	2013OC09	Part list modified with parts replaced by Note 1 Order L547, L599 and L631 removed Procedure modified for the engine support anchor bolt torque value and addition of an Annex for engine support anchor bolts torque value.	Luc Carignan
R2	2013DE20	Added note (item 1.33) to dispose of the shims if they are installed under the rubber isolators at the bumper side	Wilder Galiano

Symbol	Meaning
Empty Field	No changes, the procedure applies
+	Contract added, the procedure applies
-	Contract removed, the procedure does not apply

	CLIENT	ORDER	ROAD NUMBER		VIN (2NVY/4RKY...)		QTY
			FROM	TO	FROM	TO	
	Brampton - Ontario	L501	0917	0926	L82U893000506	L82U893000523	10
-	Brantford - Ontario	L547	10101	10105	L82X6A3000082	L82X3A3000086	5
	Brantford - Ontario	L663	—	—	L82U1B3000532	L82U1B3000532	1
	Brantford - Ontario	L718	10123	10125	L82U5C3000826	L82U9C3000828	3
	Grand River Transit - GRT - Ontario	L464	20901	20913	L82U193000296	L82U493000308	13
	Grand River Transit - GRT - Ontario	L560	21001	21009	L82U2A3000246	L82U1A3000254	9
-	Grand River Transit - GRT - Ontario	L599	—	—	L82X9B3000465	L82X2B3000467	3
-	Grand River Transit - GRT - Ontario	L631	—	—	L82X4B3000468	L82X2B3000470	3
	Grand River Transit - GRT - Ontario	L633	21101	21115	L82U7B3000289	L82U8B3000303	15
	Grand River Transit - GRT - Ontario	L668	21201	21220	L82U6C3000737	L82UXC3000756	20
	Peterborough - Ontario	L490	—	—	L82UX93000345	L82U593000348	4
	University of Colorado - Colorado	L427	—	—	S92U693000027	S92U693000027	1
	University of Colorado - Colorado	L428	—	—	S92U893000028	S92U893000028	1
	University of Colorado - Colorado	L627	—	—	S92UXB4000139	S92U6B4000140	2
	York Regional Transit - Ontario	L562	1080	1082	S92U2A3000420	S92U6A3000422	3
	York Regional Transit - Ontario	L572	1083	1094	S92U3A3000569	S92U2A3000580	12

**WARNING**

Follow your internal safety procedures.

PROCEDURE

- 1.1. Remove the rear bumper. Retain the hardware
- 1.2. Raise the vehicle.

**NOTE**

Use appropriate hoisting equipment for your protection. For information on hoisting and towing of the vehicle, see section 18: HOISTING AND TOWING in the Nova Bus maintenance manual. Respect your internal safety procedures.

- 1.3. Remove the transmission access panel. located inside the vehicle, at the rear. See Figure 1.

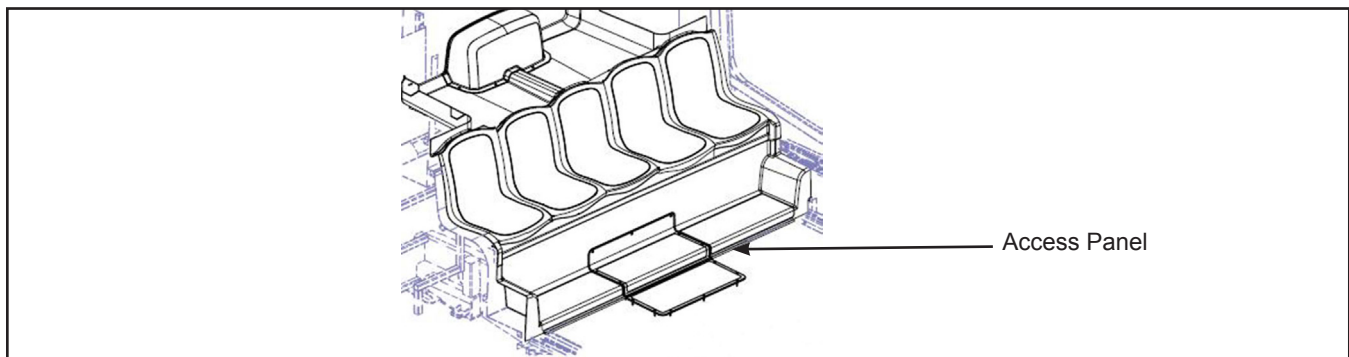

Figure 1 - Transmission Access Panel

- 1.4. Close the two auxiliary heating circuit valves. See Figure 2.

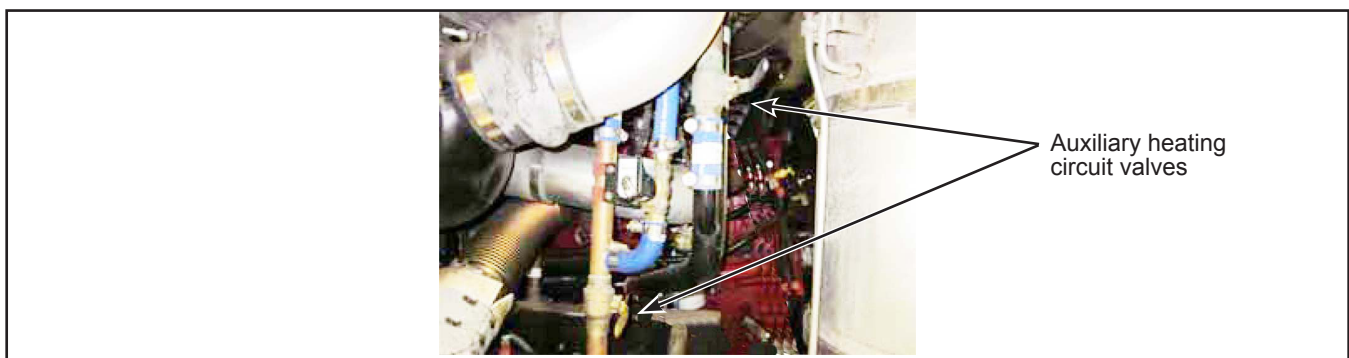

Figure 2 - Engine Compartment Auxiliary Heating Circuit Valves

- 1.5. Drain the coolant circuit. See section 09: **ENGINE COOLANT** for more information on draining.
- 1.6. Remove the rigid transmission coolant hoses. Retain the hardware. See Figure 3. This step is required to access the engine mounts.

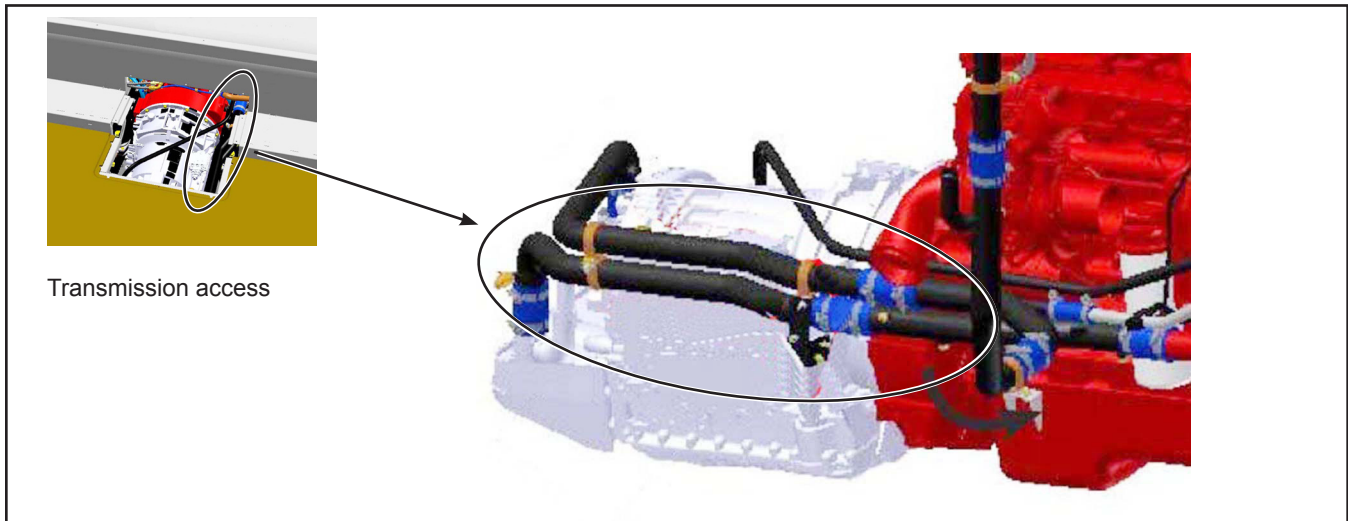

Figure 3 - Transmission Coolant Rigid Hoses

- 1.7. Support the transmission from underneath using a typical support. See Figure 4.

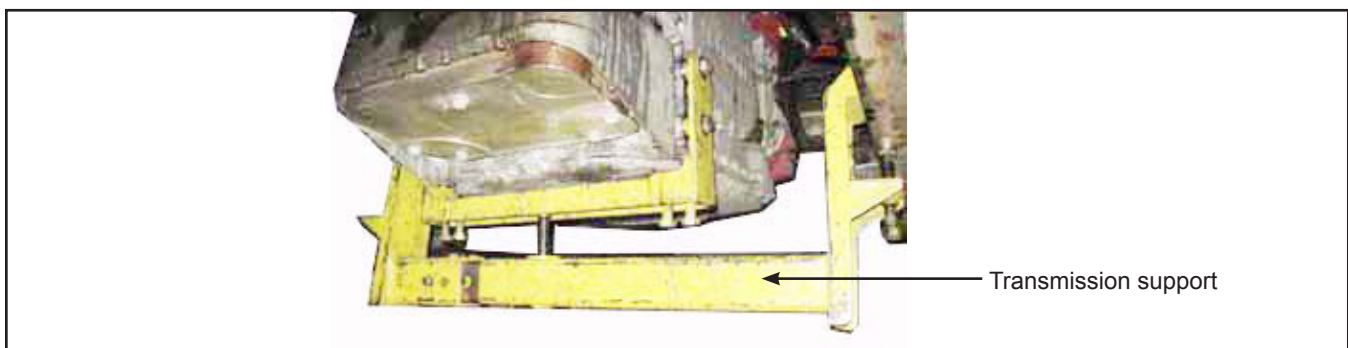

Figure 4 - Typical Transmission Support

- 1.8. Remove the P-clamps, and move the electrical harness aside. See Figure 5. This step is required to access the engine mounts.

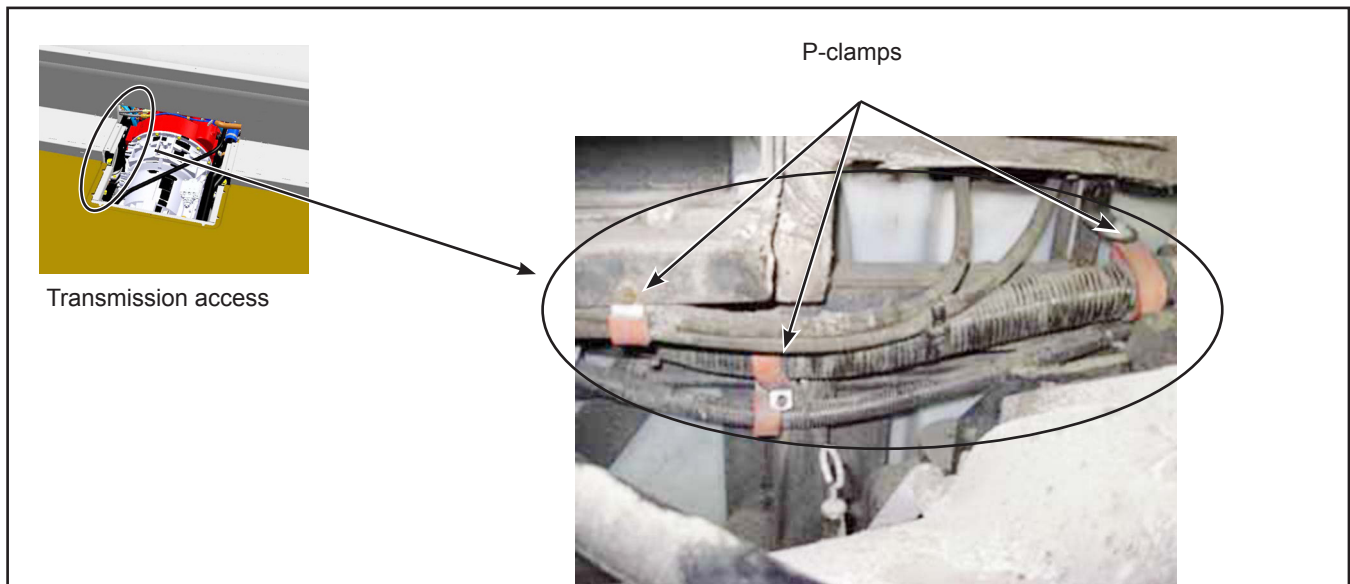

Figure 5 - Electrical Harness

ENGINE MOUNTS ON THE TRANSMISSION SIDE



NOTE

The following steps must be applied to both sides of the vehicle.

- 1.9. Remove the M24X160 bolts and nuts. See Figure 6. Retain the hardware.
1.10. Remove and dispose of the bolts and lock washers of the engine supports. See Figure 6.

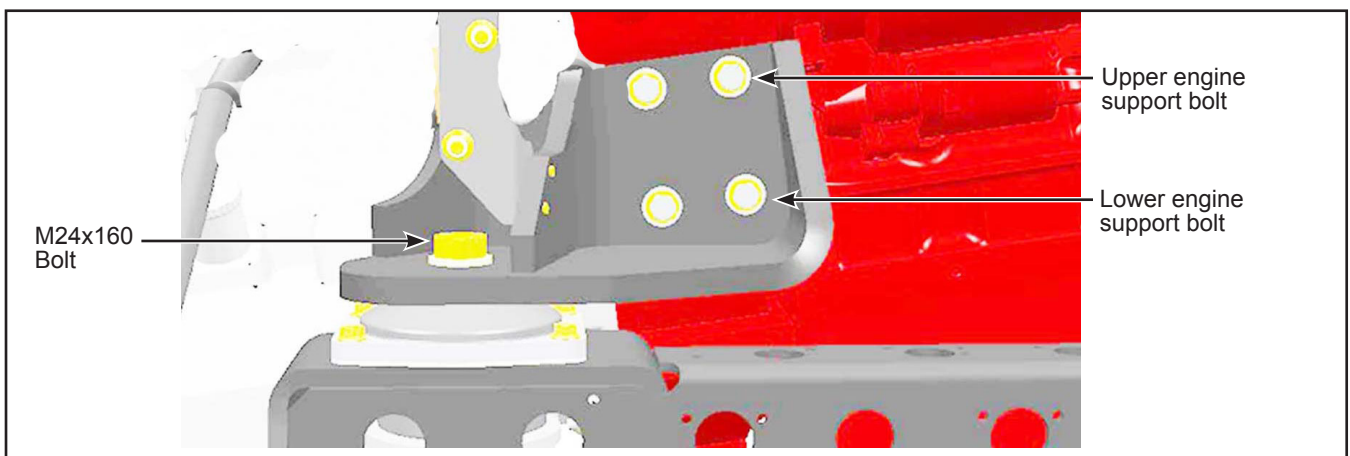

Figure 6 - Engine Support Bolts

- 1.11. Remove and dispose of the four M10X45 bolts on each rubber mount. See Figure 7.
- 1.12. Install an N69398 shim between the cradle and the rubber mount.
- 1.13. Install the new rubber isolator N68290 in its location.
- 1.14. Affix the new rubber isolator with four N56322 bolts. Tighten to the torque specified in Figure 7.

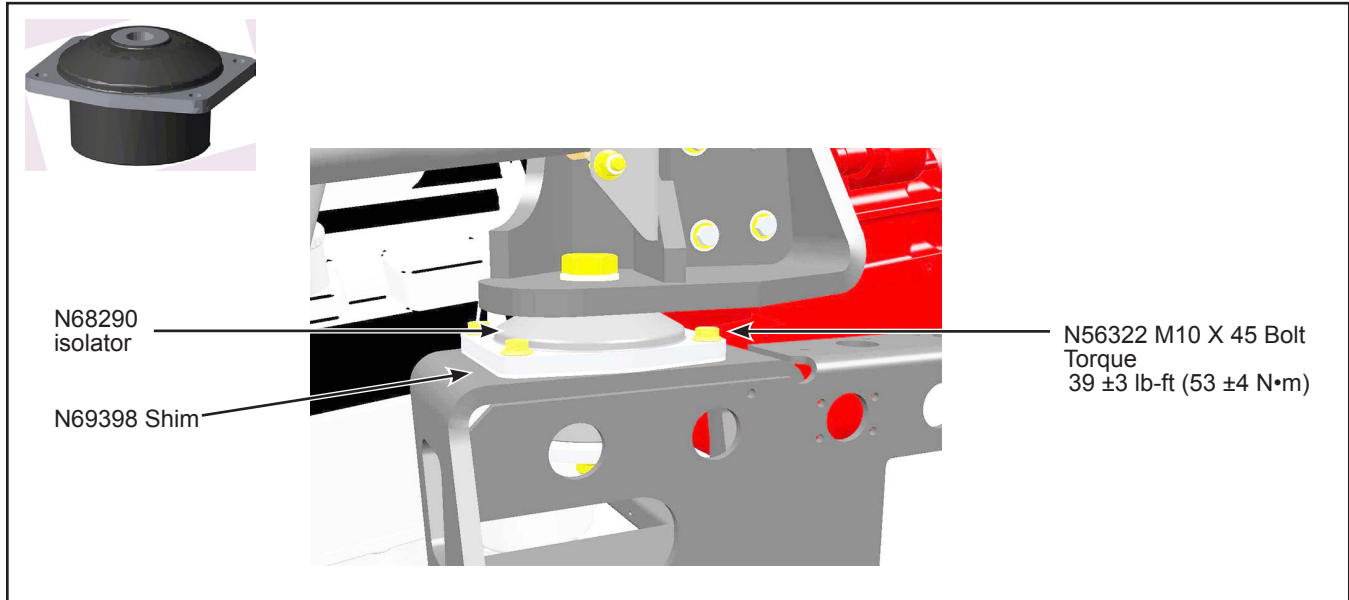

Figure 7 - Isolator Installation

- 1.15. Clean the four flywheel casing's threaded holes with an M16X45 tap. See Figure 8.



Figure 8 - Flywheel Casing's Threaded Holes

- 1.16. Spray the mounting holes with brake cleaner. Using a small brush, thoroughly clean inside the holes to remove all traces of grease, lubricant and dirt.
- 1.17. Use dry compressed air to blow off the cleaner and other particles.
- 1.18. Repeat the two previous steps before continuing.
- 1.19. Spray the threaded portion of the new anchor bolts with brake cleaner.
- 1.20. Use dry compressed air to blow off the cleaner and other particles.

**NOTE**

Installation of upper mounting bolts is performed from inside the vehicle.

Installation of lower mounting bolts is performed from underneath the vehicle.

- 1.21. Affix each engine mount to the engine flywheel housing with new anchor bolts and lockwashers. Refer to the parts manual for the bolts and lockwashers to use. Tighten to the torque indicated in Annex 1. Do **NOT** use any thread-locker.

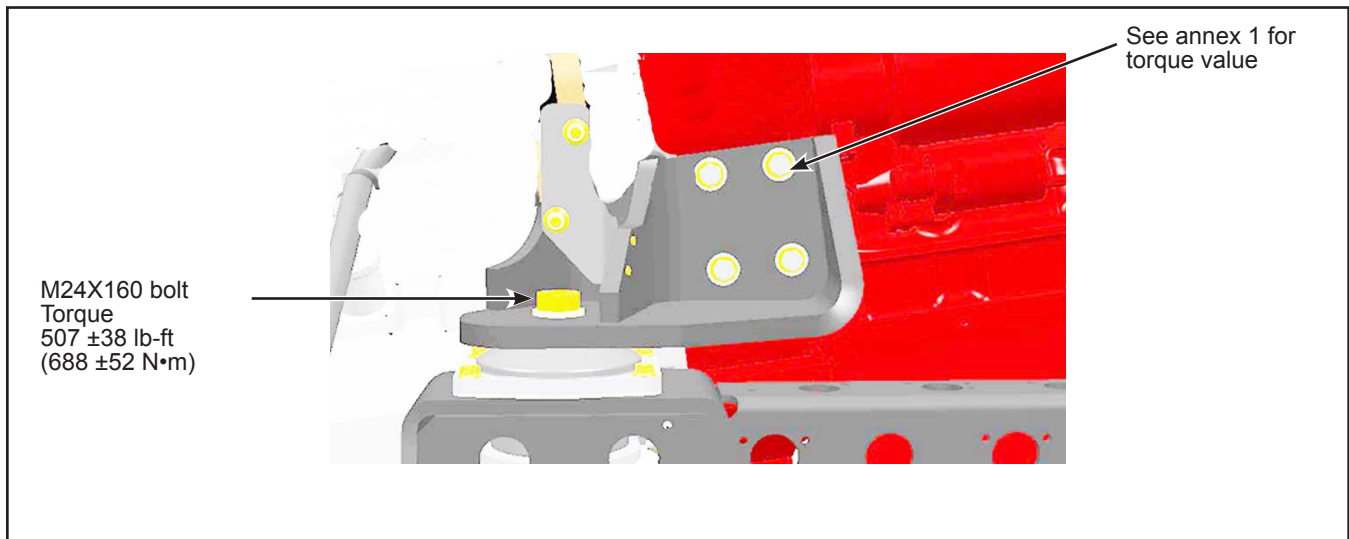

Figure 9 - Affixing Engine Support

- 1.22. Install the retained M24X160 bolt and nut. Tighten to the torque indicated in Figure 9.
- 1.23. Install the rigid transmission coolant hoses with the retained hardware.
- 1.24. Install the electrical harness with the retained hardware.
- 1.25. Close the two auxiliary heating valves.
- 1.26. Install the transmission access panel with retained hardware.
- 1.27. Fill the coolant system.
- 1.28. Remove all safety stands and transmission supports from beneath the vehicle.
- 1.29. Lower the vehicle.

ENGINE MOUNTS ON THE BUMPER SIDE**NOTE**

The following steps must be applied to both sides of the vehicle.

- 1.30. Remove the two bolts that retain the rubber isolators to the cradle. Retain the hardware. See Figure 10.
- 1.31. Lift the rear part of the engine approximately 2.5 in. (64 mm). It is suggested to support the engine on the rear oil pan bolt heads.
- 1.32. Remove the two rubber isolators from the cradle.
- 1.33. If Shims are installed between the top part of the rubber isolator and the upper side of the cradle, dispose of this shim.

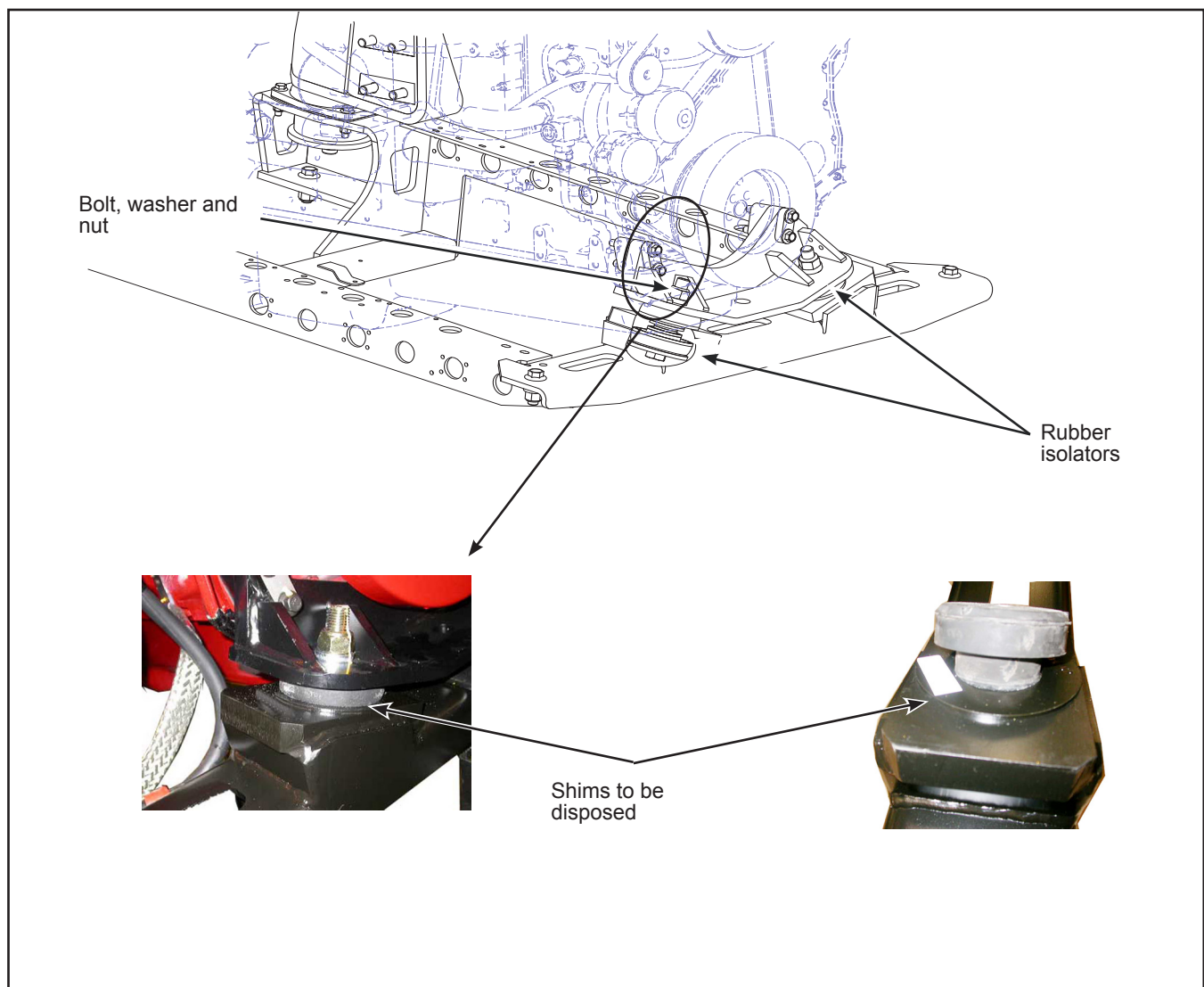

Figure 10 - Location of Rubber isolators

- 1.34. Install the two new N66492 rubber isolators on the cradle. See Figures 10 and 11.
- 1.35. Lower the engine to rest on the cradle.
- 1.36. Affix the rubber isolators with the retained hardware. Tighten to the torque specified in Figure 11.

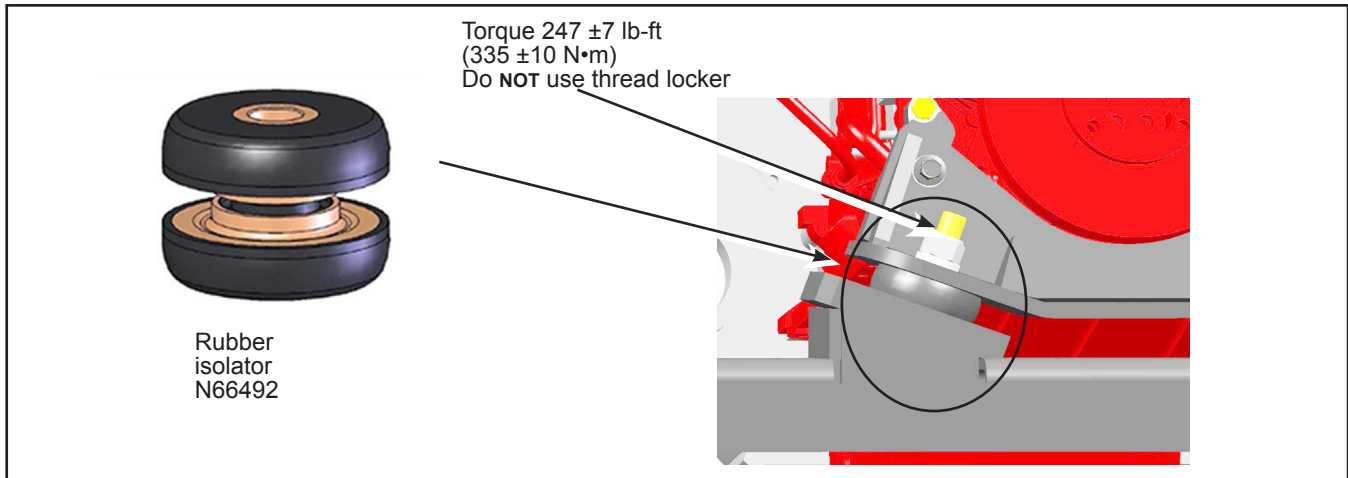

Figure 11 - Rubber Isolator Installation

- 1.37. Lower the vehicle.
- 1.38. Install the rear bumper with the retained hardware and tighten to the torque specified in Figure 12.❖

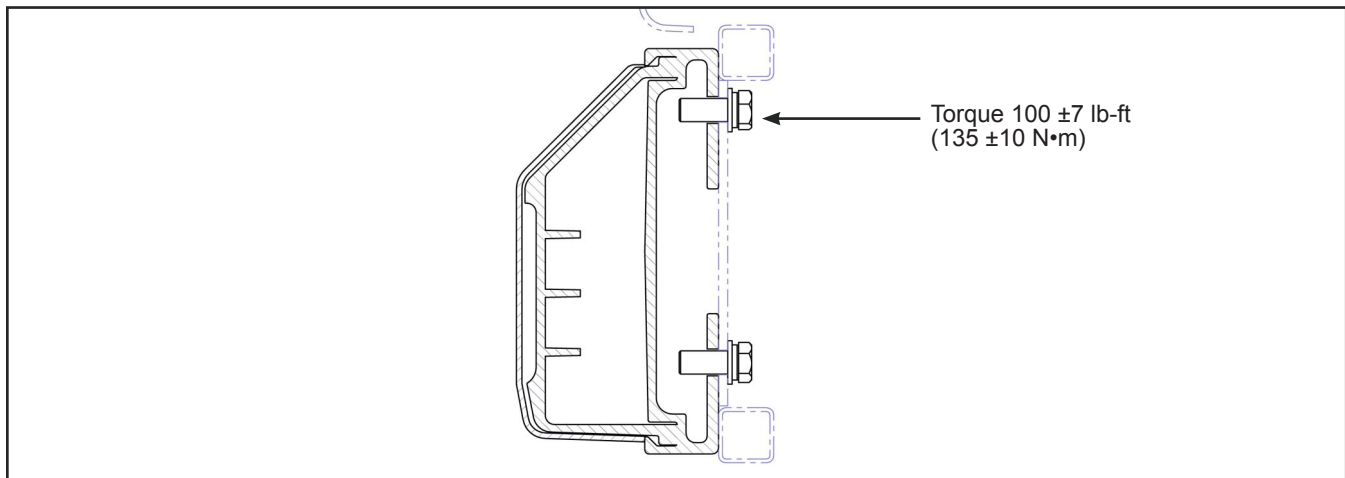

Figure 12 - Rear Bumper Torque

ANNEX 1 ENGINE MOUNT ANCHOR BOLTS TORQUE VALUE

Order	VÉHICLE N°		Torque N•m	Torque lb-ft
L501	0917	0926	150+10 -3 N•m	111+7-2 lb-ft
L547	10101	10105	125 ±20 N•m	92 ±15 lb-ft
L663	—	—	300 ±10 N•m	221 ±7 lb-ft
L718	10123	10125	300 ±10 N•m	221 ±7 lb-ft
L464	20901	20913	150+10 -3 N•m	111+7-2 lb-ft
L560	21001	21009	150+10-3 N•m	111+7-2 lb-ft
L599	—	—	125 ±20 N•m	92 ±15 lb-ft
L631	—	—	125 ±20 N•m	92 ±15 lb-ft
L633	21101	21115	300 ±10 N•m	221 ±7 lb-ft
L668	21201	21220	300 ±10 N•m	221 ±7 lb-ft
L490	—	—	150+10 -3 N•m	111+7-2 lb-ft
L427	—	—	300 ±10 N•m	221 ±7 lb-ft
L428	—	—	300 ±10 N•m	221 ±7 lb-ft
L627	—	—	300 ±10 N•m	221 ±7 lb-ft
L562	1080	1082	150+10 -3 N•m	111+7-2 lb-ft
L572	1083	1094	150+10 -3 N•m	111+7-2 lb-ft