



2013

Routan

**Quick Reference
Specification Book**

2013 Volkswagen Routan Quick Reference Specification Book

TABLE OF CONTENTS

General Information	1
Decimal and Metric Equivalents	1
Tightening Torque	2
Warnings and Cautions	4
Vehicle Identification.....	9
Vehicle Identification Number (VIN).....	9
VIN Decoder	9
Sales Codes	10
Engine Codes	10
Transmission Codes	10
Vehicle Lifting	11
Hoist and Jack Mounting Points	11

ENGINE

Engine Mechanical – 3.6L CJRA	12
General, Technical Data	12
Engine Number Location	12
Engine Data	13
Engine Assembly – 3.6L CJRA.....	14
Fastener Tightening Specifications.....	14
Crankshaft, Cylinder Block – 3.6L CJRA	15
Crankshaft Main Bearing Fitting	15
Main Bearing Journal Diameter Grade Markings	16
Upper and Lower Main Bearing Shell Markings	17
Fastener Tightening Specifications.....	18
Crankshaft Bearing Cap Tightening Specifications	19
Windage Tray Tightening Specification	20
Main Bearing Tie Bolt Tightening Specification	21
Cylinder Block Specifications	21
Crankshaft and Bearing Specifications.....	22
Connecting Rod and Bearing Specifications	
Connecting Rod	22
Connecting Rod Journal	22

Piston, Pin and Ring Specifications.....	23
Piston.....	23
Piston Pin	23
Piston Rings	24
Piston Ring Side Clearance.....	24
Piston Ring Width	24
Cylinder Head, Valvetrain – 3.6L CJRA.....	25
Fastener Tightening Specifications.....	25
Cylinder Head Specifications.....	25
Camshaft Specifications	26
Valve Specifications.....	26
Valve Spring Specifications	27
Valve Timing Specifications	27
Intake Valve	27
Exhaust Valve	27
Left Cylinder Head Tightening Specifications	28
Right Cylinder Head Tightening Specifications.....	29
Left Camshaft Bearing Cap Tightening Specifications	30
Right Camshaft Bearing Cap Tightening Specifications	31
Left Cylinder Head Cover Tightening Specification	32
Right Cylinder Head Cover Tightening Specification.....	33
Lubrication – 3.6L CJRA.....	34
Fastener Tightening Specifications.....	34
Oil Pressure Specifications.....	34
Cooling System – 3.6L CJRA	35
Fastener Tightening Specifications.....	35
Coolant System Capacity	35
Cooling Fan Specifications	35
Fuel Supply – 3.6L CJRA.....	36
Fastener Tightening Specifications.....	36
Exhaust System, Emission Controls – 3.6L CJRA.....	36
Fastener Tightening Specifications.....	36
Multipoint Fuel Injection – 3.6L CJRA	37
Technical Data	37
Fastener Tightening Specifications.....	37
Ignition – 3.6L CJRA.....	38
Fastener Tightening Specifications.....	38
Spark Plug Firing Order.....	38
Ignition Coil Resistance Specifications.....	38
Fastener Tightening Specifications.....	38

TRANSMISSION

Automatic Transmission – LGG	39
General, Technical Data	39
Transmission Identification	39
Controls, Housing	42
Fastener Tightening Specifications.....	42
Transmission Specifications	43
Low/Reverse Reaction Plate Shim Part Numbers	43
Gear Train Measurements.....	44
Number 4 Thrust Plate Shim Part Numbers	44
Output Gear Bearing Shim Part Numbers	45
Gears, Hydraulic Controls – LGG	46
Fastener Tightening Specifications.....	46
Rear Final Drive, Differential	46
Fastener Tightening Specification	46

CHASSIS

Suspension, Wheels, Steering	47
Front Suspension	47
Fastener Tightening Specifications.....	47
Frame Tightening Specifications	48
Drive Axle Tightening Specifications.....	48
Rear Suspension	49
Fastener Tightening Specifications.....	49
Wheels, Tires, Wheel Alignment.....	49
Wheel Specifications	49
Fastener Tightening Specifications.....	49
Wheel Alignment Data	50
Wheel Alignment Specified Values	50
Steering	51
Fastener Tightening Specifications.....	51
Brake System	52
Anti-lock Brake System (ABS).....	52
Fastener Tightening Specifications.....	52
Mechanical Components	53
Fastener Tightening Specifications.....	53
Brake Rotor Specifications	54
Limits/Specifications	54

Hydraulic Components	55
Fastener Tightening Specifications.....	55
Body.....	56
Body Exterior	56
Air Gap Body Dimensions	56
Body Front Tightening Specifications	59
Hood, Lids Tightening Specifications.....	59
Front Doors, Central Locking System Tightening Specifications	60
Rear Doors Tightening Specifications	60
Sunroof Tightening Specifications	60
Bumpers Tightening Specifications	61
Window Regulators Tightening Specifications.....	61
Exterior Equipment Tightening Specifications	61
Body Interior	61
Interior Equipment Tightening Specifications	61
Passenger Protection, Airbags, Seat Belts Fastener Tightening Specifications	61
Interior Trim Tightening Specifications.....	62
Seat Frames Tightening Specifications	62
Seat Upholstery, Covers Tightening Specifications	63
Heating, Ventilation And Air Conditioning	64
Heating, Ventilation.....	64
Fastener Tightening Specifications.....	64
Auxiliary Heating.....	64
Fastener Tightening Specifications.....	64
Air Conditioning	65
Refrigerant Charge Capacity	65
Fastener Tightening Specifications.....	65
Electrical System.....	66
Electrical Equipment.....	66
Battery, Starter, Generator and Cruise Control Tightening Specifications	66
Battery Specifications	66
Windshield Wiper/Washer Tightening Specifications.....	67
Wiring Tightening Specification	67

GENERAL INFORMATION

Decimal and Metric Equivalents

Distance/Length

To calculate: mm x 0.03937 = in.

mm	in.	mm	in.	mm	in.	mm	in.
0.002	0.00008	0.01	0.0004	0.1	0.004	1	0.04
0.004	0.00016	0.02	0.0008	0.2	0.008	2	0.08
0.006	0.00024	0.03	0.0012	0.3	0.012	3	0.12
0.008	0.00031	0.04	0.0016	0.4	0.016	4	0.16
0.010	0.00039	0.05	0.0020	0.5	0.020	5	0.20
0.020	0.00079	0.06	0.0024	0.6	0.024	6	0.24
0.030	0.00118	0.07	0.0028	0.7	0.028	7	0.28
0.040	0.00157	0.08	0.0031	0.8	0.031	8	0.31
0.050	0.00197	0.09	0.0035	0.9	0.035	9	0.35
0.060	0.00236	0.10	0.0039	1.0	0.039	10	0.39
0.070	0.00276	0.20	0.0079	2.0	0.079	20	0.79
0.080	0.00315	0.30	0.0118	3.0	0.118	30	1.18
0.090	0.00354	0.40	0.0157	4.0	0.157	40	1.57
0.100	0.00394	0.50	0.0197	5.0	0.197	50	1.97
0.200	0.00787	0.60	0.0236	6.0	0.236	60	2.36
0.300	0.01181	0.70	0.0276	7.0	0.276	70	2.76
0.400	0.01575	0.80	0.0315	8.0	0.315	80	3.15
0.500	0.01969	0.90	0.0354	9.0	0.354	90	3.54
0.600	0.02362	1.00	0.0394	10.0	0.394	100	3.94
0.700	0.02756	2.00	0.0787	20.0	0.787		
0.800	0.03150	3.00	0.1181	30.0	1.181		
0.900	0.03543	4.00	0.1575	40.0	1.575		
1.000	0.03937	5.00	0.1969	50.0	1.969		
2.000	0.07874	6.00	0.2362	60.0	2.362		
3.000	0.11811	7.00	0.2756	70.0	2.756		
4.000	0.15748	8.00	0.3150	80.0	3.150		
5.000	0.19685	9.00	0.3543	90.0	3.543		
6.000	0.23622	10.00	0.3937	100.0	3.937		
7.000	0.27559	20.00	0.7874				
8.000	0.31496	30.00	1.1811				
9.000	0.35433	40.00	1.5748				
10.000	0.39370	50.00	1.9685				
20.000	0.78740	60.00	2.3622				
30.000	1.18110	70.00	2.7559				
40.000	1.57480	80.00	3.1496				
50.000	1.96850	90.00	3.5433				
60.000	2.36220	100.00	3.9370				
70.000	2.75591						
80.000	3.14961						
90.000	3.54331						
100.000	3.93701						

Tightening Torque

Nm-to-lb·ft (ft·lb)

To calculate: Nm x 0.738 = lb·ft

Nm	lb·ft (ft·lb)	Nm	lb·ft (ft·lb)	Nm	lb·ft (ft·lb)
10	7	55	41	100	74
11	8	56	41	105	77
12	9	57	42	110	81
13	10	58	43	115	85
14	10	59	44	120	89
15	11	60	44	125	92
16	12	61	45	130	96
17	13	62	46	135	100
18	13	63	46	140	103
19	14	64	47	145	107
20	15	65	48	150	111
21	15	66	49	155	114
22	16	67	49	160	118
23	17	68	50	165	122
24	18	69	51	170	125
25	18	70	52	175	129
26	19	71	52	180	133
27	20	72	53	185	136
28	21	73	54	190	140
29	21	74	55	195	144
30	22	75	55	200	148
31	23	76	56	205	151
32	24	77	57	210	155
33	24	78	58	215	159
34	25	79	58	220	162
35	26	80	59	225	166
36	27	81	60	230	170
37	27	82	60	235	173
38	28	83	61	240	177
39	29	84	62	245	181
40	30	85	63	250	184
41	30	86	63	260	192
42	31	87	64	270	199
43	32	88	65	280	207
44	32	89	66	290	214
45	33	90	66	300	221
46	34	91	67	310	229
47	35	92	68	320	236
48	35	93	69	330	243
49	36	94	69	340	251
50	37	95	70	350	258
51	38	96	71	360	266
52	38	97	72	370	273
53	39	98	72	380	280
54	40	99	73	390	288
55	41	100	74	400	295

Nm-to-lb-in (in·lb), kg·cm

To calculate: Nm x 8.85 = lb-in • Nm x 10.20 = kg·cm

Nm	lb-in (in·lb)	kg·cm	Nm	lb-in (in·lb)	kg·cm
1	9	10	26	230	265
2	18	20	27	239	275
3	27	31	28	248	286
4	35	41	29	257	296
5	44	51	30	266	306
6	53	61	31	274	316
7	62	71	32	283	326
8	71	82	33	292	337
9	80	92	34	301	347
10	89	102	35	310	357
11	97	112	36	319	367
12	106	122	37	327	377
13	115	133	38	336	387
14	124	143	39	345	398
15	133	153	40	354	408
16	142	163	41	363	418
17	150	173	42	372	428
18	159	184	43	381	438
19	168	194	44	389	449
20	177	204	45	398	459
21	186	214	46	407	469
22	195	224	47	416	479
23	204	235	48	425	489
24	212	245	49	434	500
25	221	255	50	443	510

N·cm-to-lb-in (in·lb), kg·cm

To calculate: N·cm x 0.089 = lb-in • N·cm x 0.102 = kg·cm

N·cm	lb-in (in·lb)	kg·cm	N·cm	lb-in (in·lb)	kg·cm
50	4	5	250	22	25
60	5	6	300	27	31
70	6	7	350	31	36
80	7	8	400	35	41
90	8	9	450	40	46
100	9	10	500	44	51
110	10	11	550	49	56
120	11	12	600	53	61
130	12	13	650	58	66
140	12	14	700	62	71
150	13	15	750	66	76
160	14	16	800	71	82
170	15	17	850	75	87
180	16	18	900	80	92
190	17	19	950	84	97
200	18	20	1000	89	102

kg·cm-to-lb·in (in·lb), N·cm

To calculate: $\text{kg}\cdot\text{cm} \times 0.868 = \text{lb}\cdot\text{in}$ • $\text{kg}\cdot\text{cm} \times 9.81 = \text{N}\cdot\text{cm}$

kg·cm	lb·in (in·lb)	N·cm	kg·cm	lb·in (in·lb)	N·cm
5	4	49	110	95	1079
6	5	59	120	104	1177
7	6	69	130	113	1275
8	7	78	140	122	1373
9	8	88	150	130	1471
10	9	98	160	139	1569
20	17	196	170	148	1667
30	26	294	180	156	1765
40	35	392	190	165	1863
50	43	490	200	174	1961
60	52	588	210	182	2059
70	61	686	220	191	2157
80	69	785	230	200	2256
90	78	883	240	208	2354
100	87	981	250	217	2452

Warnings and Cautions

WARNINGS

- Some repairs may be beyond your capability. If you lack the skills, tools and equipment, or a suitable workplace for any procedure described in this manual, we suggest you leave such repairs to an authorized dealer service department or other qualified shop.
- Do not reuse any fasteners that have become worn or deformed during normal use. Many fasteners are designed to be used only once and become unreliable and may fail when used a second time. This includes, but is not limited to, nuts, bolts, washers, self-locking nuts or bolts, circlips and cotter pins. Always replace these fasteners with new parts.
- Never work under a lifted car unless it is solidly supported on stands designed for the purpose. Do not support a car on cinder blocks, hollow tiles or other props that may crumble under continuous load. Never work under a car that is supported solely by a jack. Never work under the car while the engine is running.
- If you are going to work under a car on the ground, make sure the ground is level. Block the wheels to keep the car from rolling. Disconnect the battery negative (-) terminal (ground strap) to prevent others from starting the car while you are under it.

- Never run the engine unless the work area is well ventilated. Carbon monoxide kills.
- Remove rings, bracelets and other jewelry so they cannot cause electrical shorts, get caught in running machinery, or be crushed by heavy parts.
- Tie back long hair. Do not wear a necktie, a scarf, loose clothing, or a necklace when you work near machine tools or running engines. If your hair, clothing, or jewelry were to get caught in the machinery, severe injury could result.
- Do not attempt to work on your car if you do not feel well. You increase the danger of injury to yourself and others if you are tired, upset, or have taken medication or any other substance that may keep you from being fully alert.
- Illuminate your work area adequately but safely. Use a portable safety light for working inside or under the car. Make sure the bulb is enclosed by a wire cage. The hot filament of an accidentally broken bulb can ignite spilled fuel, vapors or oil.
- Use a suitable container to catch draining fuel, oil, or brake fluid. Do not use food or beverage containers that might mislead someone into drinking from them. Store flammable fluids away from fire hazards. Wipe up spills at once, but do not store oily rags which can ignite and burn spontaneously.
- Always observe good workshop practices. Wear goggles when you operate machine tools or work with battery acid. Wear gloves or other protective clothing whenever the job requires working with harmful substances.
- Greases, lubricants and other automotive chemicals contain toxic substances, many of which are absorbed directly through the skin. Read the manufacturer's instructions and warnings carefully. Use hand and eye protection. Avoid direct skin contact
- Disconnect the battery negative (-) terminal (ground strap) whenever you work on the fuel or electrical system. Do not smoke or work near heaters or other fire hazards. Keep an approved fire extinguisher handy.
- Friction materials (such as brake pads or shoes or clutch discs) contain asbestos fibers or other friction materials. Do not create dust by grinding, sanding, or cleaning with compressed air. Avoid breathing dust. Breathing any friction material dust can lead to serious diseases and may result in death.

(WARNINGS cont'd on next page)

WARNINGS *(cont'd)*

- Batteries give off explosive hydrogen gas during charging. Keep sparks, lighted matches and open flame away from the top of the battery. If hydrogen gas escaping from the cap vents is ignited, it ignites the gas trapped in the cells and causes the battery to explode.
- Connect and disconnect battery cables, jumper cables or a battery charger only with the ignition off. Do not disconnect the battery while the engine is running.
- Do not quick-charge the battery (for boost starting) for longer than one minute. Wait at least one minute before boosting the battery a second time.
- Do not allow battery charging voltage to exceed 16.5 volts. If the battery begins producing gas or boiling violently, reduce the charging rate. Boosting a sulfated battery at a high charging rate can cause an explosion.
- The A/C system is filled with chemical refrigerant, which is hazardous. The A/C system should be serviced only by trained technicians using approved refrigerant recovery/recycling equipment, trained in related safety precautions, and familiar with regulations governing the discharging and disposal of automotive chemical refrigerants.
- Do not expose any part of the A/C system to high temperatures such as open flame. Excessive heat increases system pressure and may cause the system to burst.
- Some aerosol tire inflators are highly flammable. Be extremely cautious when repairing a tire that may have been inflated using an aerosol tire inflator. Keep sparks, open flame or other sources of ignition away from the tire repair area. Inflate and deflate the tire at least four times before breaking the bead from the rim. Completely remove the tire from the rim before attempting any repair.
- Some cars are equipped with a Supplemental Restraint System (SRS) that automatically deploys airbags and pyrotechnic seat belt tensioners in the event of a frontal or side impact. These are explosive devices. Handled improperly or without adequate safeguards, they can be accidentally activated and cause serious injury.
- The ignition system produces high voltages that can be fatal. Avoid contact with exposed terminals and use extreme care when working on a car with the engine running or the ignition on.

- Place jack stands only at locations specified by manufacturer. The vehicle lifting jack supplied with the vehicle is intended for tire changes only. Use a heavy duty floor jack to lift the vehicle before installing jack stands.
- Battery acid (electrolyte) can cause severe burns. Flush contact area with water, seek medical attention.
- Aerosol cleaners and solvents may contain hazardous or deadly vapors and are highly flammable. Use only in a well ventilated area. Do not use on hot surfaces (such as engines or brakes).
- Do not remove coolant reservoir or radiator cap with the engine hot. Burns and engine damage may occur.

CAUTIONS

- If you lack the skills, tools and equipment, or a suitable workshop for any procedure described in this manual, we suggest you leave such repairs to an authorized dealer or other qualified shop.
- Before starting a job, make certain that you have all the necessary tools and parts on hand. Read all the instructions thoroughly and do not attempt shortcuts. Use tools appropriate to the work and use only replacement parts meeting original specifications. Makeshift tools, parts and procedures will not make good repairs.
- Use pneumatic and electric tools only to loosen threaded parts and fasteners. Never use these tools to tighten fasteners, especially on light alloy parts. Always use a torque wrench to tighten fasteners to the tightening torque specification listed.
- Be mindful of the environment and ecology. Before you drain the crankcase, find out the proper way to dispose of the oil. Do not pour oil onto the ground, down a drain, or into a stream, pond or lake. Dispose of in accordance with Federal, State and Local laws.
- The control module for the Anti-lock Brake System (ABS) cannot withstand temperatures from a paint-drying booth or a heat lamp in excess of 95°C (203°F) and should not be subjected to temperatures exceeding 85°C (185°F) for more than two hours.
- Before doing any electrical welding on cars equipped with ABS, disconnect the battery negative (-) terminal (ground strap) and the ABS control module connector.
- Always make sure the ignition is off before disconnecting battery.

(CAUTIONS cont'd on next page)

CAUTIONS *(cont'd)*

- Label battery cables before disconnecting. On some models, battery cables are not color coded.
- Disconnecting the battery may erase fault code(s) stored in control module memory. Check for fault codes prior to disconnecting the battery cables.
- If a normal or rapid charger is used to charge the battery, disconnect the battery and remove it from the vehicle to avoid damaging paint and upholstery.
- Do not quick-charge the battery (for boost starting) for longer than one minute. Wait at least one minute before boosting the battery a second time.
- Connect and disconnect a battery charger only with the battery charger switched off.
- Sealed or “maintenance free” batteries should be slow-charged only, at an amperage rate that is approximately 10% of the battery’s ampere-hour (Ah) rating.
- Do not allow battery charging voltage to exceed 16.5 volts. If the battery begins producing gas or boiling violently, reduce the charging rate. Boosting a sulfated battery at a high charging rate can cause an explosion.

VEHICLE IDENTIFICATION

Vehicle Identification Number (VIN)

The vehicle identification number can be viewed through the windshield at the upper left corner of the instrument panel near the left windshield pillar. The VIN consists of 17 characters in a combination of letters and numbers that provide specific information about the vehicle. Decoding information is listed below.

To protect the consumer from theft and possible fraud the manufacturer is required to include a check digit at the ninth position of the vehicle identification number. The check digit is used by the manufacturer and government agencies to verify the authenticity of the vehicle and official documentation. The formula to use the check digit is not released to the general public.

Vehicle Identification

VIN Decoder

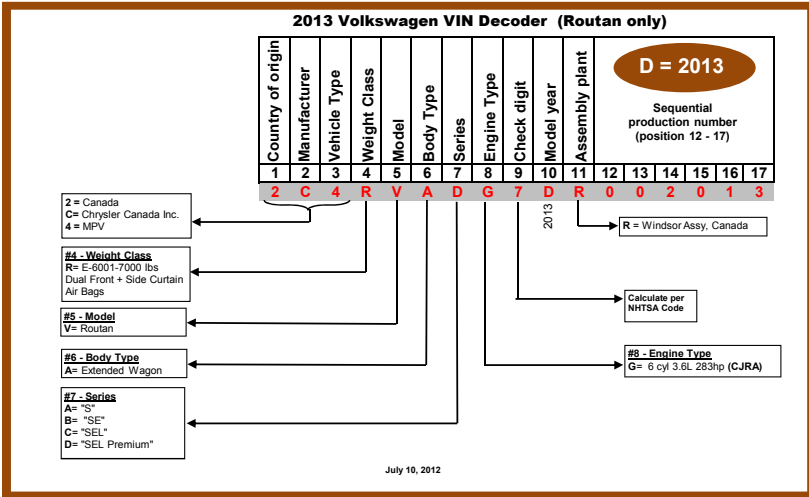

SALES CODES

Engine Codes

CJRA	3.6L 6-cylinder
-------------	-----------------

Transmission Codes

LGG	6-speed automatic
------------	-------------------

VEHICLE LIFTING

Hoist and Jack Mounting Points

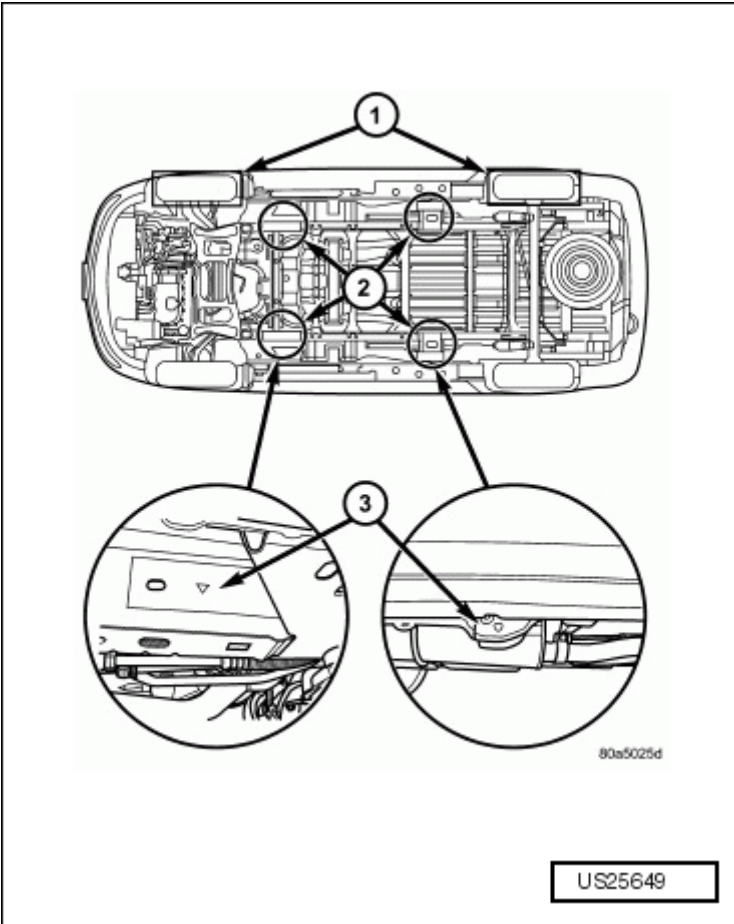

Item	Description
1	Drive on lift
2	Frame contact lift (single post)
2	Chassis lift (non-axle dual post)
2	Outboard lift (dual post)
2	Floor jack
3	S.A.E. hoisting symbols

Sales
Codes

Vehicle
Lifting

ENGINE MECHANICAL – 3.6L CJRA

General, Technical Data

Engine Number Location

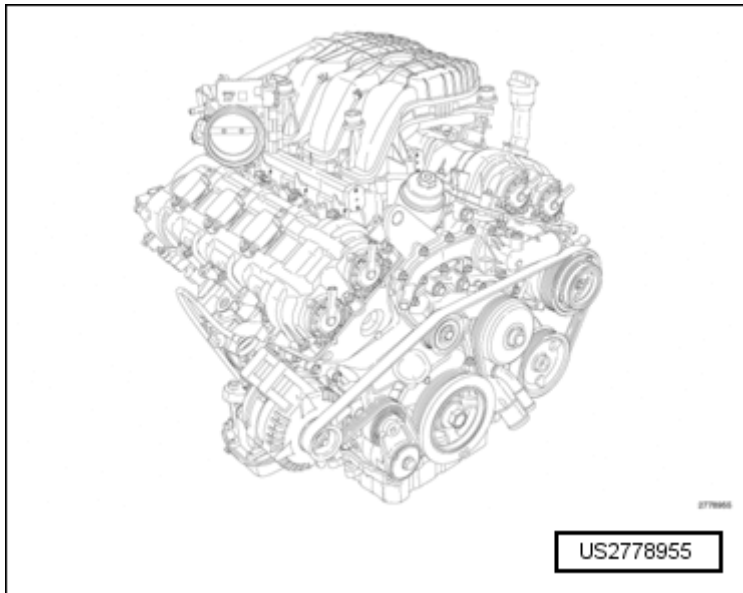

NOTE: RWD engine configuration shown, FWD similar.

The 3.6 liter (219.7 CID) flexible fuel V-6 engine features Variable Valve Timing (VVT), Dual Overhead Camshafts (DOHC) and a high pressure die-cast aluminum cylinder block with steel liners in a 60° configuration. The 3.6 liter engine has a chain driven variable discharge oil pump with a two-stage pressure regulator for improved fuel economy. The exhaust manifolds are integrated into the cylinder heads for reduced weight. The cylinders are numbered from front to rear. The right bank is numbered 1, 3, 5 and the left bank is numbered 2, 4, 6. The firing order is 1-2-3-4-5-6. The engine serial number is located on the left side of the cylinder block at the transmission flange.

Engine Data

Description	Specification	
Type	60° DOHC V-6 24-Valve	
Compression ratio	10.2:1	
Lead cylinder	#1 Right Bank	
Firing order	1-2-3-4-5-6	
	Metric	Standard
Displacement	3.6 Liters	220 Cubic Inches
Bore and stroke	96.0 x 83.0 mm	3.779 x 3.268 in.

Engine Assembly – 3.6L CJRA

Fastener Tightening Specifications

Component	Nm	ft-lb	in-lb
Engine block oil gallery plugs	10 plus an additional 1250°	-	89 plus an additional 1050°
Flexplate-to-torque converter bolt	88	65	-
Front engine mount bolt	55	41	-
Heater core supply tube-to-cylinder head bolt	12	-	106
Left/right cross member brace-to-cross member bolts	55	41	-
Left/right cross member brace-to-frame bolts	55	41	-
Left/right engine mount bracket bolts			
- M8	25	18	-
- M10	55	41	-
Left/right engine mount isolator-to-frame bolts	50	37	-
Power steering pump heat shield bolt	25	18	-
Power steering pump-to-engine bolt	25	18	-
Rear engine mount bolt	54	40	-
Rear engine mount bracket bolt	110	81	-
Rear engine mount heat shield bolt	14	-	124
Rear engine mount through bolt	60	44	-
Torque converter-to-flexplate bolt	88	65	-
Transmission-to-engine bolts	70	52	-
Transmission mount-to-transmission bolt	100	74	-
Transmission mount-to-body bolt	50	37	-
Upper engine mount bracket	20	15	-
	55	41	-

Crankshaft, Cylinder Block – 3.6L CJRA

Crankshaft Main Bearing Fitting

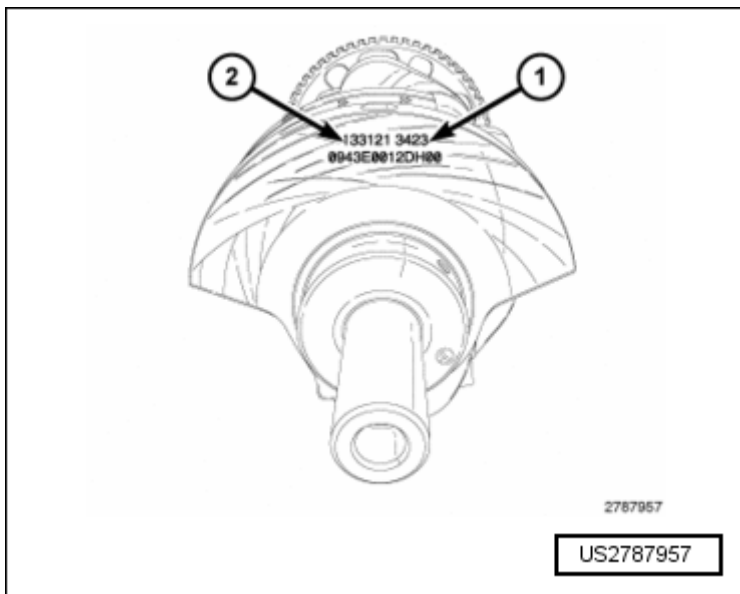

The upper and lower main bearings are select fit to achieve proper oil clearances. Crankshaft main bearing journal diameter grade markings (1) are stamped into the front crankshaft counterweight. These marks are read from left to right, corresponding with journal number 1, 2, 3, 4.

Crankshaft main bearing journal diameter grade markings correspond to specific journal diameters. The chart below identifies the five crankshaft grade markings and their associated journal diameters.

Crankshaft marking	Journal size mm (in.)
1	71.9870 - 71.9905 (2.8341 - 2.8343)
2	71.9906 - 71.9941 (2.8343 - 2.8344)
3	71.9942 - 71.9977 (2.8344 - 2.8345)
4	71.9978 - 72.0013 (2.8346 - 2.8347)
5	72.0014 - 72.0050 (2.8347 - 2.8348)

Main Bearing Journal Diameter Grade Markings

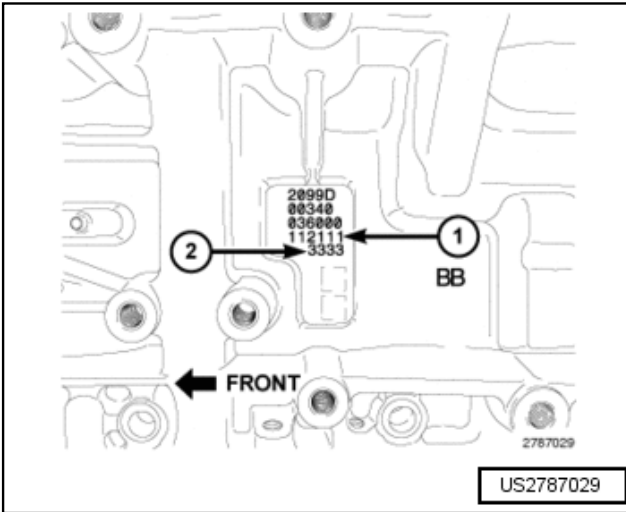

Engine block main bearing journal diameter grade markings (2) are stamped into the left side of the engine block. These marks are read from left to right, corresponding with journal number 1, 2, 3, 4.

Engine block main bearing journal grade markings correspond to specific journal diameters. The chart below identifies the five engine block grade markings and their associated journal diameters.

Engine block marking	Journal size mm (in)
1	77.0055 - 77.0090 (3.0317 - 3.0318)
2	77.0019 - 77.0054 (3.0316 - 3.0317)
3	76.9983 - 77.0018 (3.0314 - 3.0316)
4	76.9947 - 76.9982 (3.0313 - 3.0314)
5	76.9910 - 76.9946 (3.0311 - 3.0313)

For upper and lower main bearing selection, obtain the grade identification marks from the crankshaft and engine block. Main bearings are available in five sizes. Upper and lower sizes can be mixed on a journal in order to achieve the desired oil clearance. The next chart identifies the five sizes available and how they should be selected based on crankshaft and engine block grade markings.

Engine block marking	Crankshaft marking				
	1	2	3	4	5
1	1/1	1/2	2/2	2/3	3/3
2	1/2	2/2	2/3	3/3	3/4
3	2/2	2/3	3/3	3/4	4/4
4	2/3	3/3	3/4	4/4	4/5
5	3/3	3/4	4/4	4/5	5/5

Upper/lower main bearings to achieve 0.024 - 0.050 mm (0.0009 - 0.0020 in) oil clearance.

Upper and Lower Main Bearing Shell Markings

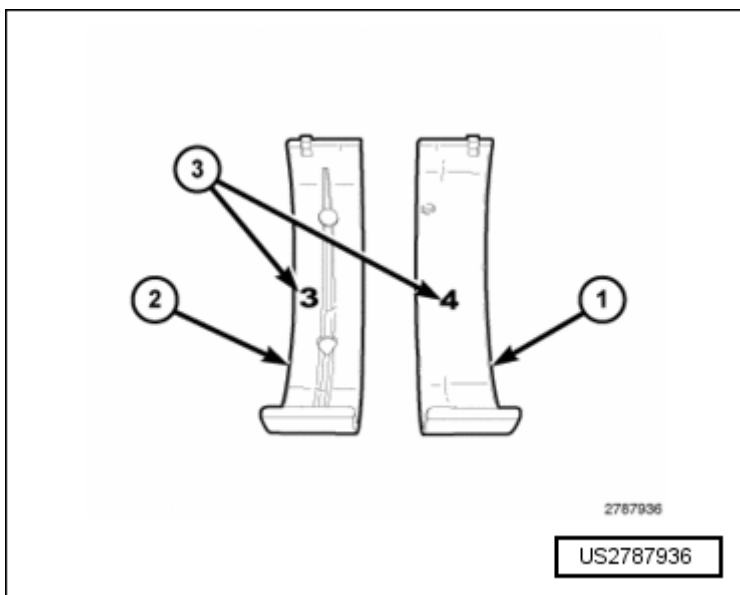

The upper main bearing shell (2) and lower main bearing shell (1) are marked with the bearing size (3) on the bearing lining surface. The upper and lower bearings are available in five different sizes and can be mixed on a journal in order to achieve the proper oil clearance.

Upper and lower main bearing shells are available in five sizes. The next chart identifies the five bearing sizes.

Bearing marking	Size mm (in)
1	2.4951 - 2.4987 (0.0982 - 0.0984)
2	2.4915 - 2.4951 (0.0981 - 0.0982)
3	2.4879 - 2.4915 (0.0979 - 0.0981)
4	2.4843 - 2.4879 (0.0978 - 0.0979)
5	2.4807 - 2.4843 (0.0977 - 0.0978)

NOTE: Crankshaft thrust washers are not selectable and are only available in a single thickness.

Bearing oil clearance can also be determined by using Plastigage or equivalent.

Fastener Tightening Specifications

Component	Nm	ft-lb	in-lb
Accessory drive belt idler pulley bolt	28	21	-
Accessory drive belt tensioner assembly bolt	55	41	-
Flexplate-to-crankshaft bolt	95	70	-
Connecting rod cap bolt ¹⁾	20 plus an additional 90° (¼ turn)	15 plus an additional 90° (¼ turn)	-
Crankshaft main bearing cap bolts ²⁾	21 plus an additional 90° (¼ turn)	15 plus an additional 90° (¼ turn)	-
Idler puller 11	25	18	
Main bearing tie bolts	28	21	-
Oil pump pickup tube bolt	28	21	-
Rear oil seal retainer bolt	12	-	106
Vibration damper bolt	355	-	262
Windage tray bolt	21 plus an additional 90° (¼ turn)	15 plus an additional 90° (¼ turn)	-

¹⁾ Replace fastener(s).

²⁾ Check the main bearing cap bolts for necking by holding a scale or straight edge against the threads. Replace the bolt if all the threads do not contact the scale.

Crankshaft Bearing Cap Tightening Specifications

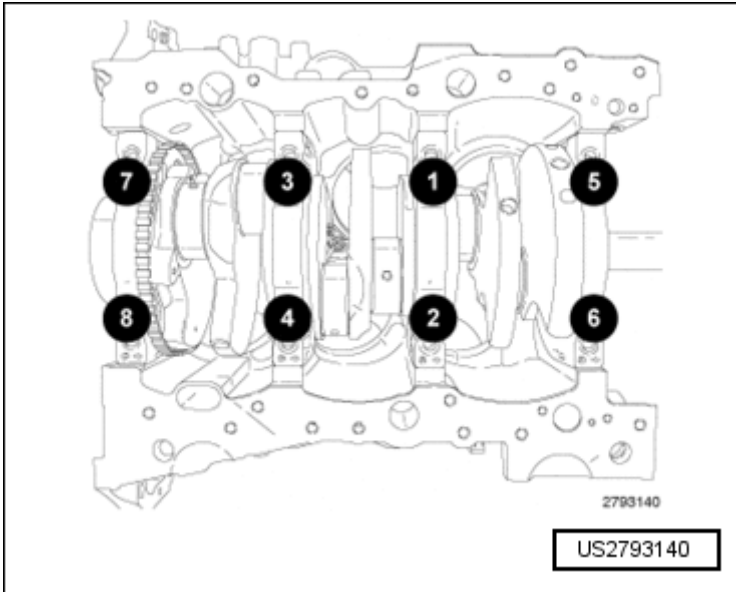

Step	Component	Nm	ft-lb
1	Tighten bolts 1 through 8 in sequence ¹⁾	20 plus an additional 90° (¼ turn)	15 plus an additional 90° (¼ turn)

¹⁾ Check the main bearing cap bolts for necking by holding a scale or straight edge against the threads. Replace the bolt if all the threads do not contact the scale.

Windage Tray Tightening Specification

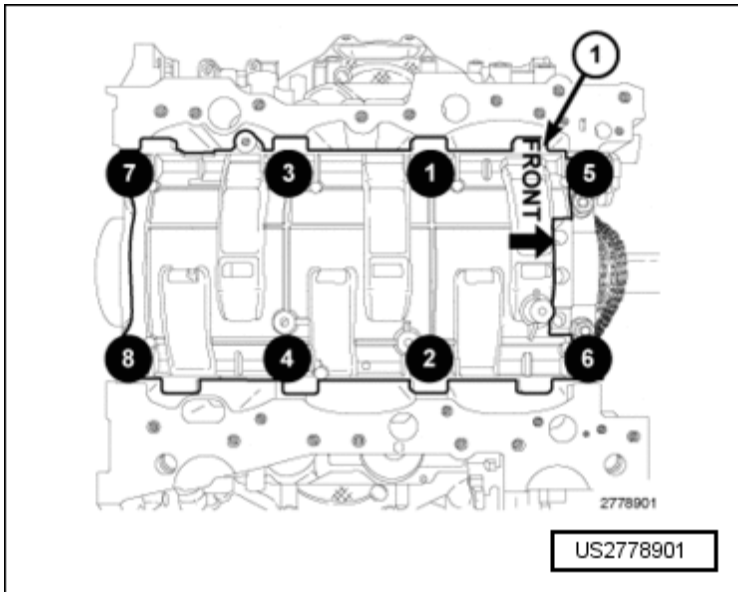

Step	Component	Nm	ft-lb
1	Tighten bolts 1 through 8 in sequence ¹⁾	21 plus an additional 90° (¼ turn)	15 plus an additional 90° (¼ turn)

¹⁾ Check the main bearing cap bolts for necking by holding a scale or straight edge against the threads. Replace the bolt if all the threads do not contact the scale.

Main Bearing Tie Bolt Tightening Specification

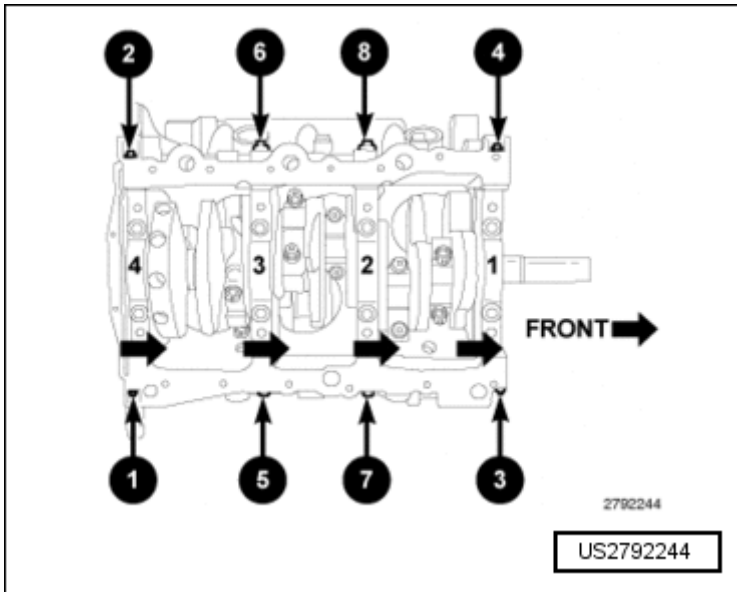

Step	Component	Nm	ft-lb
1	Tighten bolts 1 through 8 in sequence	28	21

Cylinder Block Specifications

Description	Specification	
	Metric (mm)	Standard (in.)
Cylinder bore diameter - grade 1	95.995 ± 0.005	3.7793 ± 0.0002
Cylinder bore diameter - grade 2	96.005 ± 0.005	3.7797 ± 0.0002
Cylinder bore out-of-round (Max.)	0.009	0.00035
Cylinder bore cylindricity	0.014	0.0006
Crankshaft bore taper ¹⁾ (Max.)	0.006	0.0002

¹⁾ Measured over length of bulkhead.

Crankshaft and Bearing Specifications

Description	Specification	
	Metric (mm)	Standard (in.)
Diameter	71.996 ± 0.009	2.8345 ± 0.0035
Bearing clearance	0.024 - 0.050	0.0009 - 0.0020
Bearing clearance (Max.)	0.050	0.0020
Out-of-round (Max.)	0.005	0.0002
Taper (Max.)	0.005	0.0002
End play	0.050 - 0.290	0.0020 - 0.0114
End play (Max.)	0.290	0.0114

Connecting Rod and Bearing Specifications Connecting Rod

Description	Specification	
	Metric	Standard
Bearing clearance (with crush)	0.023 - 0.064 mm	0.0009 - 0.0025 in.
Side clearance	0.070 - 0.370 mm	0.0028 - 0.0146 in.
Side clearance (Max.)	0.370 mm	0.0146 in.
Piston pin bore diameter	22.016 ± 0.005 mm	0.8668 ± 0.0002 in.
Bearing bore-out-of-round (Max.)	0.008 mm	0.0003 in.
Total weight (less bearing)	546.7 ± 8 grams	19.28 ± 0.28 oz.

Connecting Rod Journal

Description	Specification	
	Metric (mm)	Standard (in.)
Diameter	59.0 ± 0.009	2.3228 ± 0.0035
Bearing clearance	0.023 - 0.064	0.0009 - 0.0025
Out-of-round (Max.)	0.005	0.0002
Taper (Max.)	0.005	0.0002

Piston, Pin and Ring Specifications

Piston

Description	Specification	
	Metric	Standard
Material	Cast Aluminum Alloy	
Piston diameter (metal-to-metal) - Grade 1	95.955 ± 0.005 mm	3.7778 ± 0.0002 in.
Piston diameter (metal-to-metal) - Grade 2	95.965 ± 0.005 mm	3.7781 ± 0.0002 in.
Piston diameter (metal-to-coating) - Grade 1	95.970 - 96.000 mm	3.7783 - 3.7795 in.
Piston diameter (metal-to-coating) - Grade 2	95.980 - 96.010 mm	3.7787 - 3.7835 in.
Clearance at size location (metal-to-metal)	0.030 - 0.050 mm	0.0012 - 0.0020 in.
Clearance at size location (metal-to-coating)	0.010 - 0.030 mm	0.0004 - 0.0012 in.
Piston weight	354 - 364 grams	12.487 - 12.840 oz.
Piston pin offset	0.8 mm	0.031 in.
Piston ring groove diameter - No. 1	88.24 - 88.44 mm	3.474 - 3.482 in.
Piston ring groove diameter - No. 2	86.54 - 86.74 mm	3.407 - 3.415 in.
Piston ring groove diameter - No. 3	89.16 - 89.36 mm	3.510 - 3.518 in.

Piston Pin

Description	Specification	
	Metric (mm)	Standard (in.)
Type	Full Floating	
Pin diameter	21.9985 ± 0.0015	0.86608 ± 0.00006
Clearance in piston	0.002 - 0.011	0.0001 - 0.0004
Clearance in rod	0.011 - 0.024	0.0004 - 0.0009

Piston Rings

Description	Specification	
	Metric (mm)	Standard (in.)
Ring gap - Number 1 ring (Top)	0.25 - 0.40	0.010 - 0.016
Ring gap - Number 2 ring (Center)	0.30 - 0.45	0.012 - 0.018
Ring gap - Oil control ring (Steel rails)	0.15 - 0.66	0.006 - 0.026

Piston Ring Side Clearance

Description	Specification	
	Metric (mm)	Standard (in.)
Number 1 ring (Top)	0.025 - 0.083	0.0010 - 0.0033
Number 2 ring (Center)	0.030 - 0.078	0.0012 - 0.0031
Oil control ring (Steel rails)	0.007 - 0.173	0.0003 - 0.0068

Piston Ring Width

Description	Specification	
	Metric (mm)	Standard (in.)
Number 1 ring (Top)	3.00 - 3.20	0.118 - 0.126
Number 2 ring (Center)	3.59 - 3.85	0.141 - 0.152
Oil control ring (Steel Rails)	1.930 - 2.083	0.076 - 0.082

Cylinder Head, Valvetrain – 3.6L CJRA

Fastener Tightening Specifications

Component	Nm	ft-lb	in-lb
Camshaft bearing cap bolt	9.5	-	84
Camshaft chain guide (primary) bolt	12	-	106
Camshaft chain idler sprocket bolt	25	18	-
Camshaft chain LH guide (secondary) bolt	12	-	106
Camshaft chain RH guide (secondary) bolt	12	-	106
Camshaft chain LH tensioner (secondary) bolt	12	-	106
Camshaft chain RH tensioner (secondary) bolt	12	-	106
Camshaft chain tensioner (primary) bolt	12	-	106
Camshaft thrust plate bolt	28	21	-
Cylinder head cover bolt	12	-	106
Engine timing cover (M6 bolts)	12	-	106
Engine timing cover (M8 bolt)	25	18	-
Engine timing cover (M10 bolts)	55	41	-
Oil control valves	150	110	-
Rocker arm shaft bolt	31	23	-
Wire harness retainer bracket-to-LH cylinder head bolt	12	-	106

Cylinder Head Specifications

Description	Specification	
	Metric (mm)	Standard (in.)
Gasket Thickness* (Compressed)	0.48 - 0.60 mm	0.019 - 0.024 in.
Flatness (Head Gasket Surface)	0.09 mm	0.0035 in.
Valve Seat Angle	44.75° ± 0.25° from the valve guide axis	
Valve Seat Runout (relative to the valve guide axis) - Intake and Exhaust	0.050 mm	0.002 in.
Intake Valve Seat Width	1.0 - 1.2 mm	0.04 - 0.05 in.
Exhaust Valve Seat Width	1.41 - 1.61 mm	0.055 - 0.063 in.
Guide Bore Diameter (Std.)	6.00 - 6.02 mm	0.236 - 0.237 in.
Valve Guide Height** - Intake and Exhaust	16.05 - 16.55 mm	0.632 - 0.652 in.

*Measured at the fire ring, not at the outer edge**Measured from cylinder head surface to top of guide

Camshaft Specifications

Description	Specification	
	Metric	Standard
Bore Diameter - No. 1 Cam Towers	32.020 - 32.041 mm	1.2606 - 1.2615 in..
Bore Diameter - No. 2, 3, 4 Cam Towers	24.020 - 24.041 mm	0.9457 - 0.9465 in..
Bearing Journal Diameter - No. 1	31.976 - 31.995 mm	1.2589 - 1.2596 in.
Bearing Journal Diameter - No. 2, 3, 4	23.977 - 23.996 mm	0.9440 - 0.9447 in.
Bearing Clearance - No. 1	0.025 - 0.065 mm	0.00010 - 0.0026 in.
Bearing Clearance - No. 2, 3, 4	0.024 - 0.064 mm	0.0009 - 0.0025 in.
End Play	0.075 - 0.251 mm	0.003 - 0.010 in.

Valve Specifications

Component	Specification	
	Metric	Standard
Exhaust length (Overall)	115.6 ± 0.23 mm	4.551 ± 0.009 in.
Exhaust valve lift (Zero lash)	10.0 mm	0.394 in.
Face angle	45.25° ± 0.25°	
Head diameter (Exhaust)	30.0 ± 0.100 mm	1.181 ± 0.004 in.
Head diameter (Intake)	39.0 ± 0.100 mm	1.535 ± 0.004 in.
Intake length (Overall)	116.54 ± 0.23 mm	4.588 ± 0.009 in.
Intake valve lift (Zero lash)	10.3 mm	0.406 in.
Stem diameter (Exhaust)	5.961 ± 0.009 mm	0.2347 ± 0.0004 in.
Stem diameter (Intake)	5.968 ± 0.009 mm	0.2350 ± 0.0004 in.
Stem-to-guide clearance (Intake) (New)	0.023 - 0.061 mm	0.0009 - 0.0024 in.
Stem-to-guide clearance (Exhaust) (New)	0.030 - 0.068 mm	0.0012 - 0.0027 in.
Stem-to-guide clearance (Intake) (Max. rocking method)	0.29 mm	0.011 in.
Stem-to-guide clearance (Exhaust) (Max. rocking method)	0.37 mm	0.015 in.
Valve stem tip height ¹⁾ (Intake)	52.4 - 53.5 mm	2.063 - 2.106 in.
Valve stem tip height ¹⁾ (Exhaust)	51.8 - 52.9 mm	2.039 - 2.083 in.

¹⁾ Valve tip to aluminum spring seat boss.

Valve Spring Specifications

Description	Specification	
	Metric	Standard
Free Length - Intake and Exhaust (Approx.)	52.5 mm	2.067 in.
Installed Height - Intake and Exhaust (Spring seat top to bottom of retainer)	40.0 mm	1.575 in..
Number of Coils - Intake and Exhaust	9.35	
Spring Force - Exhaust (Valve Open)	76 ± 30 N @ 10.0 mm	152 ± 6 lbs. @ 0.3937 in.
Spring Force - Intake (Valve Open)	676 ± 30 N @ 10.0 mm	152 ± 6 lbs. @ 0.3937 in.
Spring Force - Intake and Exhaust (Valve Closed)	295 ± 13 N @ 40.0 mm	66 ± 3 lbs. @ 1.57 in.
Wire Diameter - Intake and Exhaust	3.18 x 3.99 mm (ovate)	0.125 x 0.157 in. (ovate)

Valve Timing Specifications

Intake Valve

Description	Specification
Opens	2° (ATDC)
Closes	82° (ABDC) or 262° (ATDC)
Duration	260°
Centerline	128°
Note: Units are in crank degrees, using 0.1524 mm (0.006 in.) valve lift as the threshold.	

Exhaust Valve

Description	Specification
Opens	59° (BBDC) or 239° (BTDC)
Closes	12° (ATDC)
Duration	251°
Centerline	10°
Note: Units are in crank degrees, using 0.1524 mm (0.006 in.) valve lift as the threshold.	

Left Cylinder Head Tightening Specifications

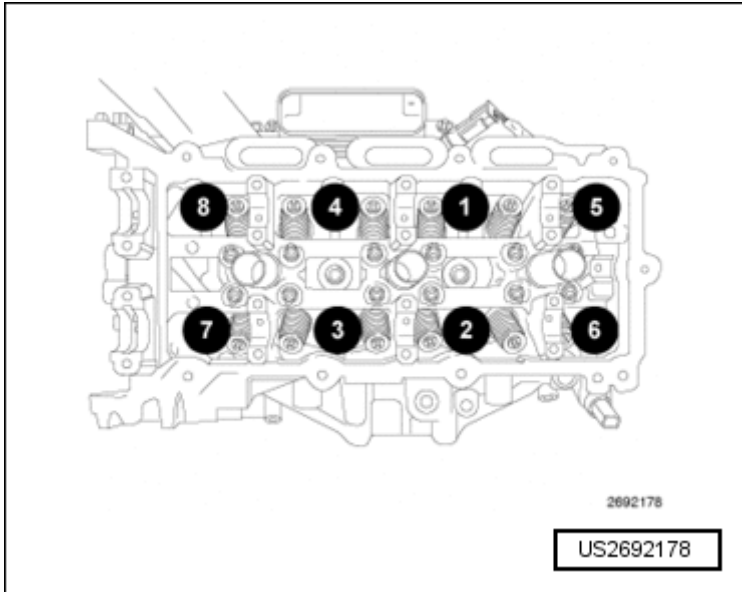

Step	Component	Nm	ft-lb
1	Tighten bolts 1 through 8 in sequence	30	22
2	Tighten bolts 1 through 8 in sequence	45	33
3	Tighten bolts 1 through 8 in sequence ¹⁾	an additional 75°	
4	Tighten bolts 2 and 3 ¹⁾	an additional 50°	
5	Loosen all fasteners in reverse of sequence shown		
6	Tighten bolts 1 through 8 in sequence	30	22
7		45	33
8	Tighten bolts 1 through 8 in sequence ¹⁾	an additional 60° (1/6 turn)	
9	Tighten bolts 1 through 8 in sequence ¹⁾	an additional 70°	

¹⁾ Do not use a torque wrench for this step.

Right Cylinder Head Tightening Specifications

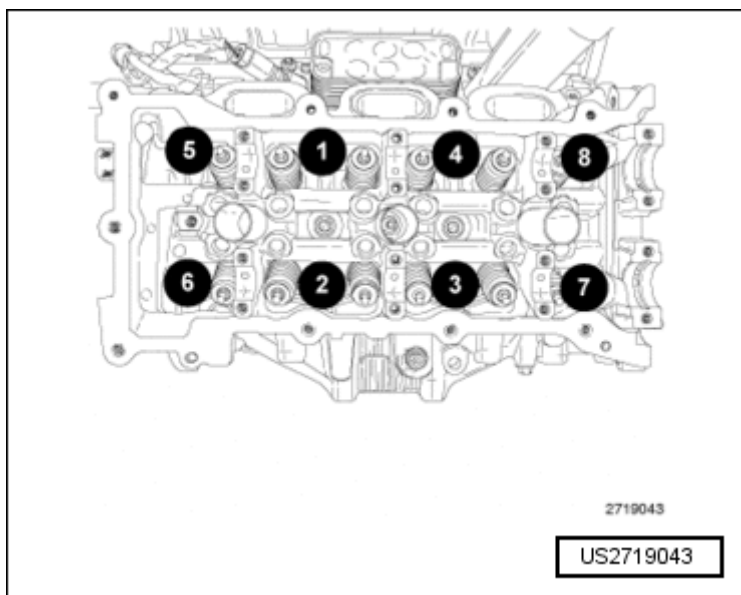

Step	Component	Nm	ft-lb
1	Tighten bolts 1 through 8 in sequence	30	22
2	Tighten bolts 1 through 8 in sequence	45	33
3	Tighten bolts 1 through 8 in sequence ¹⁾	an additional 75°	
4	Tighten bolts 2 and 3 ¹⁾	an additional 50°	
5	Loosen all fasteners in reverse of sequence shown		
6	Tighten bolts 1 through 8 in sequence	30	22
7	Tighten bolts 1 through 8 in sequence	45	33
8	Tighten bolts 1 through 8 in sequence ¹⁾	an additional 60° (1/6 turn)	
9	Tighten bolts 1 through 8 in sequence ¹⁾	an additional 70°	

¹⁾ Do not use a torque wrench for this step.

Left Camshaft Bearing Cap Tightening Specifications

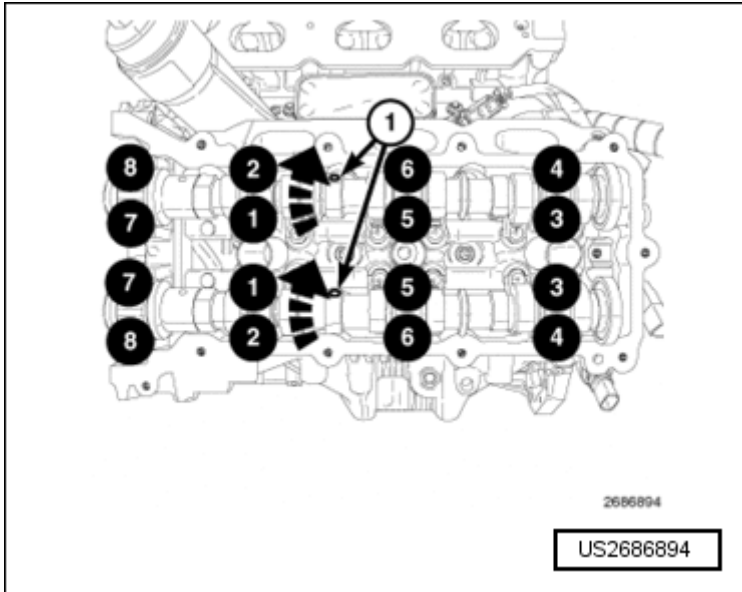

Install the left side camshaft(s) approximately 30° counterclockwise from the Top Dead Center (TDC) position (1). This places the camshafts at the neutral position (no valve load) easing the installation of the camshaft bearing caps.

NOTE: Caps are identified numerically (1 through 4), intake or exhaust (I or E) and should be installed from the front to the rear of the engine. Install all caps with the notch forward so the stamped arrows (<) on the caps point toward the front of the engine.

Step	Component	Nm	in-lb
1	Tighten bolts 1 through 8 in sequence	Hand-tighten	
2	Tighten bolts 1 through 8 in sequence	9.5	84

Right Camshaft Bearing Cap Tightening Specifications

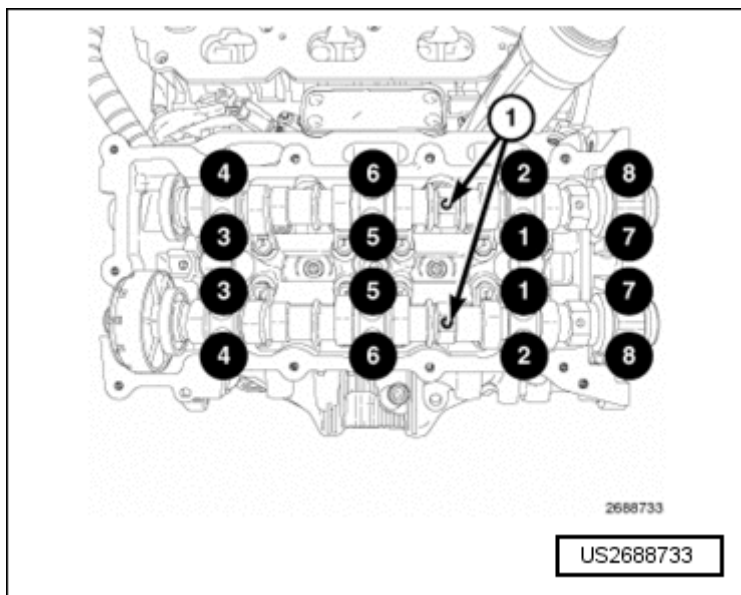

Install the right side camshaft(s) at Top Dead Center (TDC) by positioning the alignment holes (1) vertically. This places the camshafts at the neutral position (no valve load) easing the installation of the camshaft bearing caps.

NOTE: Caps are identified numerically (1 through 4), intake or exhaust (I or E) and should be installed from the front to the rear of the engine. Install all caps with the notch forward so the stamped arrows (<) on the caps point toward the front of the engine.

Step	Component	Nm	in-lb
1	Tighten bolts 1 through 8 in sequence	Hand-tighten	
2	Tighten bolts 1 through 8 in sequence	9.5	84

Left Cylinder Head Cover Tightening Specification

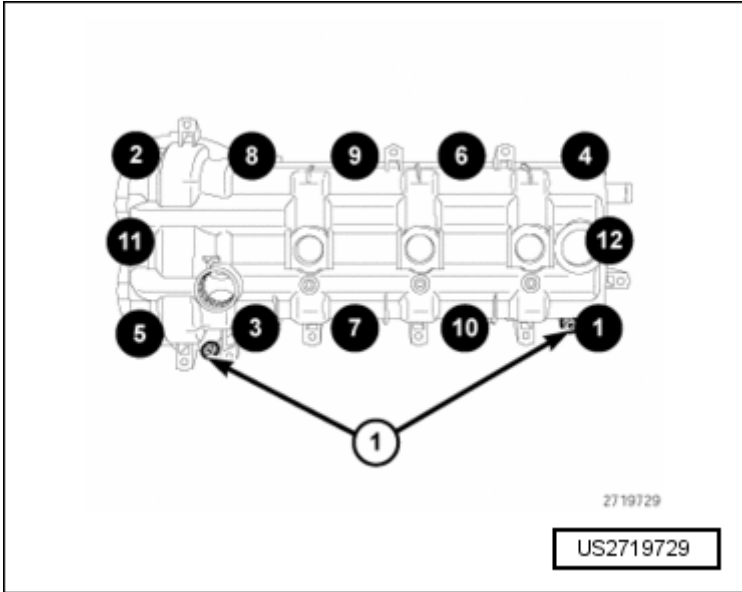

Align the locator pins (1) to the cylinder head and install the cylinder head cover.

Step	Component	Nm	in-lb
1	Tighten bolts 1 through 12 in sequence	12	106

Right Cylinder Head Cover Tightening Specification

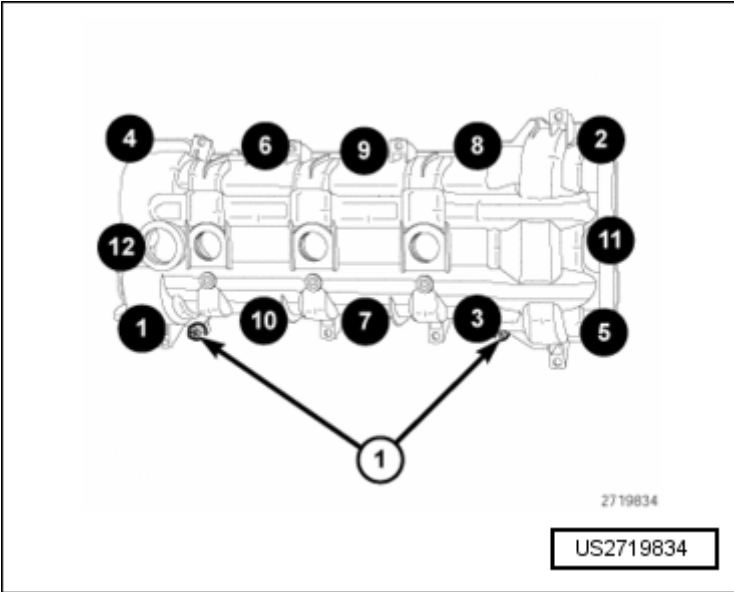

Align the locator pins (1) to the cylinder head and install the cylinder head cover.

Step	Component	Nm	in-lb
1	Tighten bolts 1 through 12 in sequence	12	106

Lubrication – 3.6L CJRA

Fastener Tightening Specifications

Component	Nm	ft-lb	in-lb
Coolant tube-to-oil pan bolt	12	-	106
Drain Plug-to-oil pan bolt	27	20	-
Lower oil pan-to-upper oil pan bolt/nut	11	-	97
Oil cooler bolt	12	-	106
Oil cooler-to-oil filter housing screw	4	-	35
Oil filter cap-to-oil filter housing	25	18	-
Oil filter housing-to-engine bolt	12	-	106
Oil pressure sensor	20	-	177
Oil pump bolt	12	-	106
Oil pump cover bolt	12	-	106
Oil pump pickup tube-to-oil pump bolt	12	-	106
Oil pump sprocket-to-oil pump chain bolt	25	18	-
Oil temperature sensor	20	-	177
Piston oil cooler jet-to-engine block	6	-	53
Rear oil seal retainer flange bolt	12	-	106
Timing gear splash shield	4	-	35
Upper oil pan-to-engine bolt	25	18	-
Upper oil pan-to-transmission bolt	55	41	-

Oil Pressure Specifications

Description	Specification	
	Metric (kPa)	Standard (psi)
(NOTE: At normal operating temperatures)		
Pressure @ curb idle speed ¹⁾	34.7 (minimum)	5 (minimum)
Pressure @ 600 - 1200 RPM	34.7 (warm) - 958.0 (cold)	5 (warm) - 139 (cold)
Pressure @ 1201 - 3500 RPM	206.8 (warm) - 958.0 (cold)	30 (warm) - 139 (cold)
Pressure @ 3501 - 6400 RPM	427.0 (warm) - 958.0 (cold)	62 (warm) - 139 (cold)

¹⁾ CAUTION: If oil pressure is zero at idle, DO NOT run engine at 3000 RPM.

Cooling System – 3.6L CJRA

Fastener Tightening Specifications

Component	Nm	ft-lb	in-lb
Coolant outlet connector/ thermostat housing bolt	12	9	-
Engine block heater bolt	12	-	106
Engine Coolant Temperature (ECT) sensor	11	8	-
Radiator fan bolt	5	-	45
Radiator-to-A/C condenser bolt	5	-	45
Radiator upper bracket mounting nut	12	9	106
Water pump bolt	12	9	-
Water pump inlet tube bolt	12	9	-

Coolant System Capacity

Description	Specification	
	Metric	Standard
3.6L engine	12.6L	13.4 qt.

Cooling Fan Specifications

Coolant temperature		
Fan operation speeds	Initial	Maximum
Fan on	104°C (220°F)	110°C (230°F) fan speed duty-cycles (ramps-up) from 30% to 99%
Fan off	101°C (214°F)	Fan speed duty-cycles (ramps-down) from 99% to 30%

A/C pressure		
Fan operation speeds	Initial	Maximum
Fan on	1,724 kPa (250 psi)	2,068 kPa (300 psi) Fan speed duty-cycles (ramps-up) from 30% to 99%
Fan off	1,710 kPa (248 psi)	Fan speed duty-cycles (ramps-down) from 99% to 30%

**Engine –
3.6L CJRA**

Cooling Fan Specifications (cont'd)

Transmission oil temperature		
Fan operation speeds	Initial	Maximum
Fan on	96°C (204°F)	111°C (232°F) fan speed duty cycles (ramps-up) from 30% to 99%
Fan off	89°C (192°F)	Fan speed duty cycles (ramps-down) from 99% to 30%

Fuel Supply – 3.6L CJRA

Fastener Tightening Specifications

Component	Nm	ft-lb	in-lb
Accelerator pedal bolt	12	-	106
Air cleaner outlet duct clamp	4	-	35
EVAP canister bracket bolt	55	41	-
Fuel fill tube	12	-	106
Fuel rail bolt	7	62	-
Fuel tank strap bolt	48	35	-

Exhaust System, Emission Controls – 3.6L CJRA

Fastener Tightening Specifications

Component	Nm	ft-lb	in-lb
Catalytic converter-to-exhaust manifold flange bolt	37	27	-
Cross under pipe bracket bolt	28	21	-
Exhaust lower retainer plate bolt	37	27	-
Exhaust manifold/catalytic converter-to-cross under pipe bolt	28	21	-
Exhaust manifold heat shield bolt/nut	12	-	106
Exhaust manifold stud	27	20	-
Exhaust pipe-to-cross under pipe nut	30	22	-
Heat shield fastener	2.6	-	23
Insulator mounting bracket bolt	28	21	-
Muffler/resonator band clamp	54	40	-

Multipoint Fuel Injection – 3.6L CJRA

Technical Data

Engine code	Cjra
Idle check	
Engine idle speed RPM ¹⁾	640 to 760
Engine Control Module (ECM)	
System designation	Motronic MED 9.1
Part number	Refer to the Electronic Parts Catalog (ETKA)
Engine Speed (RPM) limitation	approximately 6700

Fastener Tightening Specifications

Component	Nm	ft-lb	in-lb
Air cleaner hose clamps	4	-	35
Crankshaft Position (CKP) sensor	12	-	106
Evaporative Emission (EVAP) canister bracket bolt	55	41	-
Evaporative Emission (EVAP) purge solenoid nut	10	-	89
Fuel tank strap bolt	55	41	-
Lower intake manifold bolt	8	-	71
Oxygen Sensor (O2S)			
- Right downstream oxygen sensor	45	33	-
- All other oxygen sensors	43	32	-
Positive Crankcase Ventilation (PCV) valve	4	-	35
Powertrain Control Module (PCM) bolt	4.5	-	40
Power steering reservoir nut	12	-	106
Throttle body-to-intake manifold bolt	7	-	62
Upper intake manifold bolt	9	-	80
Upper intake manifold support bracket-to-cylinder head bolt	20	-	177
Upper intake manifold support bracket nuts	10	-	89

Ignition – 3.6L CJRA

Fastener Tightening Specifications

Component	Nm	ft-lb	in-lb
Camshaft Position (CMP) sensor bolt	9	-	80
Crankshaft Position (CKP) sensor bolt	12	-	106
Ignition coil capacitor bolt	10	-	89
Ignition coil mounting bolts	8	-	71
Knock Sensor (KS) ¹⁾	22	16	-
Spark plugs	17.5	13	-
Variable valve timing solenoids	4	-	35

¹⁾ Do not apply any sealant, thread-locker or adhesive to bolts. Poor sensor performance may result.

Spark Plug Firing Order

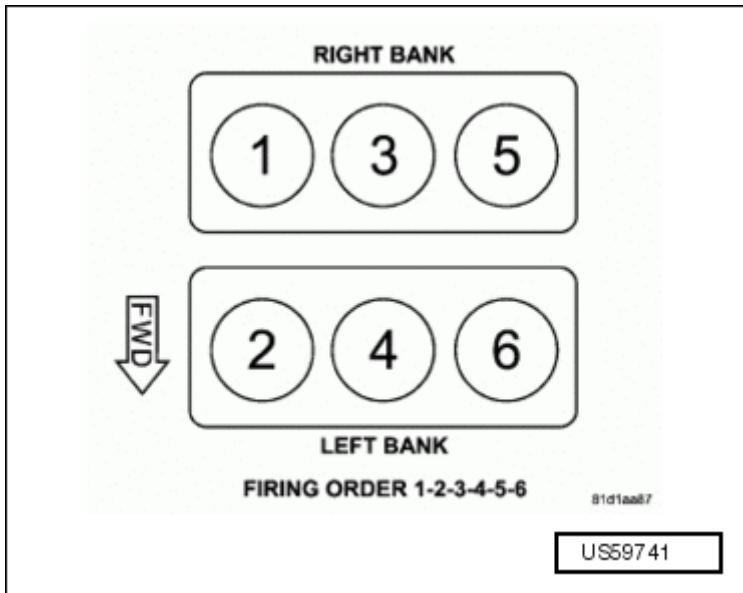

Ignition Coil Resistance Specifications

Engine	Primary Resistance at 21°C-27°C (70°F-80°F)	Secondary Resistance at 21°C-27°C (70°F-80°F)
3.6L	0.6 - 0.9 Ohms	6,000 - 9,000 Ohms

Fastener Tightening Specifications

Engine	Spark Plug	Electrode Gap
3.6L V-6	RER8ZWYCB4	1.0 mm (.040 in.)

AUTOMATIC TRANSMISSION – LGG

General, Technical Data

Transmission Identification

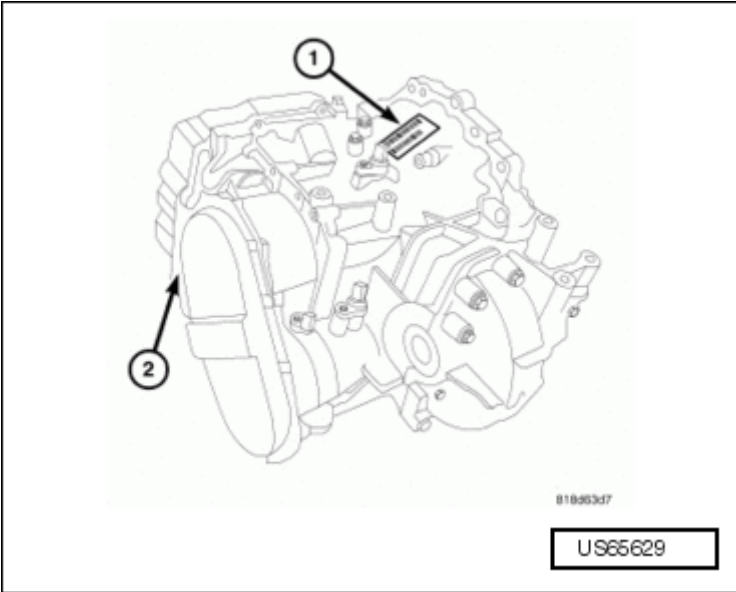

The 62TE transaxle is identified by a barcode label (1) affixed to the transaxle case, or the PK number (2).

Transmission Identification (cont'd)

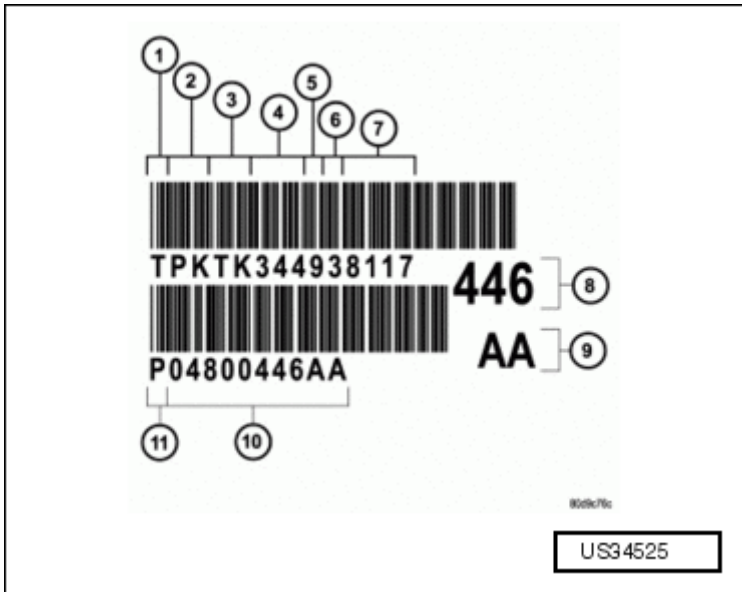

- 1 - T = Traceability
- 2 - Supplier code (PK = Kokomo)
- 3 - Component code (TK = Kokomo Transmission)
- 4 - Build day (344 = Dec. 9)
- 5 - Build year (9 = 1999)
- 6 - Line/shift code (3 = 3rd shift)
- 7 - Build sequence number
- 8 - Last three of P/N
- 9 - Alpha
- 10 - Transaxle part number
- 11 - P = Part number

The label contains a series of digits that can be translated into useful information such as transaxle part number, date of manufacture, manufacturing origin, plant shift number, build sequence number.

If the tag is not legible or missing, the PK number, which is stamped into the transaxle case behind the transfer gear cover, can be referred to for identification. This number differs slightly in that it contains the entire transaxle part number, rather than the last three digits.

62TE		Elements Applied							
Gear	Ratio	UD	OD	R	2-4	L-R	LC	DC	ORC
1	4.127	A				A	A ^		H
2	2.842	A				A		A	
3*	2.284	A			A		A ^		H
4	1.573	A			A			A	
4	1.452	A	A				A ^		H
5	1.000	A	A					A	
6	0.689		A		A			A	
R	3.215			A		A	A		

A = Applied

H = Holding

* = Limp-in Mode

^ = Applied in coast only

The 62TE provides seven forward ratios and one reverse.

The underdrive compounder assembly uses direct and reduction has operation.

Notice in the chart the 2-3, 3-2, and 4-2 shifts require a double swap shift. This occurs when two elements are turned off while two different elements are engaged.

This clutch-to-clutch synchronization takes place within 40 to 70 milliseconds, producing a smooth shift. If the underdrive compounder assembly shifts too early (in relation to the shifts taking place in the main centerline), a shudder or harsh shift results. If the underdrive assembly shifts too late, the driver experiences a double bump sensation.

To avoid a double swap shift in a 6-4 downshift, the transaxle shifts into 4th prime which requires the deactivation of the overdrive clutch and the simultaneous application of the underdrive clutch.

Controls, Housing

Fastener Tightening Specifications

Component	Nm	ft-lb	in-lb
Cable adjustment screw	8	-	71
Case plug	24	18	-
Compounder bearing retainer bolt	12	-	106
Crankshaft Position (CKP) sensor bolt	12	-	106
Detent arm bolt	6	-	53
Differential cover bolt	61	45	-
Differential output bearing cover bolt	12	-	106
Exhaust stand-off bracket bolt	95	70	-
Flexplate bolt	88	65	-
Front mount bracket bolt	100	74	-
Front mount through bolt	50	37	-
Ground cable bolt	10	-	89
Input speed sensor bolt	12	-	106
Left transaxle mount bolt	100	74	-
Low/reverse clutch piston retainer screw	5	-	44
Manual lever set screw	1	-	8.8
Oil pump bolt	30	22	-
Output speed sensor bolt	12	-	106
Output transfer gear bolt	271	200	-
Park pawl pipe plug	27	20	-
Park pawl shaft set screw	1	-	8.8
Power steering line bolt	10	-	89
Pressure tap plug	6	-	53
Rear transaxle mount bracket bolt	100	74	-
Remote pinion cover bolt	12	-	106
Shift lever bolt	20	15	-
Speed sensor bolt	12	-	106
Stirrup strap bolt	23	17	-
Torque converter dust shield bolt	10	-	89
Transaxle-to-engine bolt	70	52	-
Transaxle mount bracket bolt	75	55	-
Transfer gear cover bolt	12	-	106
Transfer gear nut (underdrive compounder side)	271	200	-
Transfer shaft speed sensor bolt	12	-	106
Transmission cross member bolt	50	37	-
Transmission fluid filter nut	5	-	44
Transmission fluid filter oil pan bolt	6	-	53
Valve body bolt	6	-	53
Valve body oil pan bolt	6	-	53

Transmission Specifications

Description	Specification
Output shaft gear drag torque	3 to 8 in-lb.
Low/reverse clutch pack clearance	0.89 to 1.47 mm (0.035 to 0.058 in.)
Reverse clutch (select snap ring)	0.76 to 1.245 mm (0.030 to 0.049 in.)
Overdrive clutch (no selection)	0.491 to 2.345 mm (0.019 to 0.092 in.)
Underdrive clutch (select pressure plate)	0.91 to 1.47 mm (0.036 to 0.058 in.)
2/4 clutch clearance	0.76 to 2.64 mm (0.030 to 0.104 in.)
Input shaft end play	0.005 - 0.025 in.
Final drive remote pinion drag torque	2 to 8 in-lb of drag
Differential turning torque	10 to 20 in-lb of drag
Low clutch clearance	0.48 to 0.76 mm (0.019 to 0.030 in.)
Direct clutch pack clearance	0.95 to 1.41 mm (0.037 to 0.056 in.)

Low/Reverse Reaction Plate Shim Part Numbers

Note: This chart is for reference only. Refer to the Electronic Parts Catalog (ETKA) for allocation.

Thickness	Part Number
5.88 mm (0.232 in.)	4799846AA
6.14 mm (0.242 in.)	4799847AA
6.40 mm (0.252 in.)	4799848AA
6.66 mm (0.262 in.)	4799849AA
6.92 mm (0.273 in.)	4799855AA

Gear Train Measurements

Description	Metric (mm)	Standard (in.)
Direct clutch retainer bushing	39.71 - 39.75	1.563 - 1.565
Front/rear carrier pinion end play	0.15 - 0.61	0.006 - 0.024
Front sun gear bushings	29.55 - 29.60	1.163 - 1.165
Low clutch retainer bushing (steel)	28.22 - 28.26	1.111 - 1.113
Low clutch retainer bushing (brass)	30.01 - 30.03	1.181 - 1.182
Oil pump between both gear end faces and the reaction shaft support	0.020 - 0.046	0.0008 - 0.0018
Oil pump inner gear-to-crescent	0.093 - 0.385	0.0036 - 0.0151
Oil pump outer gear-to-crescent	0.060 - 0.298	0.0023 - 0.0117
Oil pump outer gear-to-pump pocket	0.089 - 0.202	0.0035 - 0.0079
Oil pump reaction support sleeve	45.27 - 45.31	1.782 - 1.784
Output carrier pinion end play	0.15 - 0.76	0.006 - 0.030
Overdrive hub/shaft bushing	21.52 - 21.58	0.847 - 0.850
Rear carrier bushing	29.75 - 30.00	1.171 - 1.181
Torque converter hub bushing	38.019 - 38.11	1.499 - 1.501

Number 4 Thrust Plate Shim Part Numbers

This chart is for reference only. Allocation, refer to the Electronic Parts Catalog (ETKA).

Thickness	Part Number
1.60 mm (0.063 in.)	4431665AB
1.73 mm (0.068 in.)	3836237AB
1.80 mm (0.071 in.)	4431666AB
1.96 mm (0.077 in.)	3836238AB
2.03 mm (0.080 in.)	4431667AB
2.16 mm (0.085 in.)	3836239AB
2.24 mm (0.088 in.)	4431668AB
2.39 mm (0.094 in.)	3836240AB
2.46 mm (0.097 in.)	4431669AB
2.62 mm (0.103 in.)	3836241AB
2.67 mm (0.105 in.)	4446670AB
2.90 mm (0.114 in.)	4446671AB

Output Gear Bearing Shim Part Numbers

Note: This chart is for reference only. Refer to the Electronic Parts Catalog (ETKA) for allocation.

End Play	Shim Needed	Part Number
0.05 mm (0.002 in.)	4.42 mm (0.174 in.)	4412830AB
0.08 mm (0.003 in.)	4.38 mm (0.172 in.)	4412829AB
0.10 mm (0.004 in.)	4.38 mm (0.172 in.)	4412829AB
0.13 mm (0.005 in.)	4.34 mm (0.171 in.)	4412828AB
0.15 mm (0.006 in.)	4.30 mm (0.169 in.)	4412827AB
0.18 mm (0.007 in.)	4.30 mm (0.169 in.)	4412827AB
0.20 mm (0.008 in.)	4.26 mm (0.168 in.)	4412826AB
0.23 mm (0.009 in.)	4.22 mm (0.166 in.)	4412825AB
0.25 mm (0.010 in.)	4.22 mm (0.166 in.)	4412825AB
0.28 mm (0.011 in.)	4.18 mm (0.165 in.)	4412824AB
0.30 mm (0.012 in.)	4.14 mm (0.163 in.)	4412823AB
0.33 mm (0.013 in.)	4.14 mm (0.163 in.)	4412823AB
0.36 mm (0.014 in.)	4.10 mm (0.161 in.)	4412822AB
0.38 mm (0.015 in.)	4.10 mm (0.161 in.)	4412822AB
0.41 mm (0.016 in.)	4.06 mm (0.160 in.)	4412821AB
0.43 mm (0.017 in.)	4.02 mm (0.158 in.)	4412820AB
0.46 mm (0.018 in.)	4.02 mm (0.158 in.)	4412820AB
0.48 mm (0.019 in.)	3.98 mm (0.157 in.)	4412819AB
0.51 mm (0.020 in.)	3.94 mm (0.155 in.)	4412818AB
0.53 mm (0.021 in.)	3.94 mm (0.155 in.)	4412818AB
0.56 mm (0.022 in.)	3.90 mm (0.154 in.)	4412817AB
0.58 mm (0.023 in.)	3.90 mm (0.154 in.)	4412817AB
0.61 mm (0.024 in.)	3.86 mm (0.152 in.)	4412816AB
0.64 mm (0.025 in.)	3.82 mm (0.150 in.)	4412815AB
0.66 mm (0.026 in.)	3.82 mm (0.150 in.)	4412815AB
0.69 mm (0.027 in.)	3.78 mm (0.149 in.)	4412814AB
0.71 mm (0.028 in.)	3.74 mm (0.147 in.)	4412813AB
0.74 mm (0.029 in.)	3.74 mm (0.147 in.)	4412813AB
0.76 mm (0.030 in.)	3.70 mm (0.146 in.)	4412812AB
0.79 mm (0.031 in.)	3.66 mm (0.144 in.)	4412811AB
0.81 mm (0.032 in.)	3.66 mm (0.144 in.)	4412811AB
0.84 mm (0.033 in.)	3.62 mm (0.143 in.)	4412810AB
0.86 mm (0.034 in.)	3.62 mm (0.143 in.)	4412810AB
0.89 mm (0.035 in.)	3.58 mm (0.141 in.)	4412809AB
0.91 mm (0.036 in.)	3.54 mm (0.139 in.)	4412808AB
0.94 mm (0.037 in.)	3.54 mm (0.139 in.)	4412808AB
0.97 mm (0.038 in.)	3.50 mm (0.138 in.)	4412807AB

Gears, Hydraulic Controls – LGG

Fastener Tightening Specifications

Component	Nm	ft-lb	in-lb
Clamp plate bolt	6	-	53
Pressure control sensor bolt	6	-	53
Pressure control solenoid bolt	6	-	53
Reaction shaft-to-pump housing bolt	27	20	-
Reaction shaft support bolt	28	21	-
Transfer gear nut (underdrive compounder side)	271	200	-
Transfer plate bolt	6	-	53
Transmission valve body oil pan bolt	12	-	106

Rear Final Drive, Differential

Fastener Tightening Specification

Component	Nm	ft-lb	in-lb
Rear gear-to-case bolt	95	70	-

SUSPENSION, WHEELS, STEERING

Front Suspension

Fastener Tightening Specifications

Component	Nm	ft-lb	in-lb
Ball joint nut	27 plus an additional 180° (½ turn)	20 plus an additional 180° (½ turn)	-
Brake caliper adapter mounting bolts	169	125	-
Brake shield mounting screws	8	6	71
Hub and bearing mounting bolts	50	37	-
Hub nut	160	118	-
Lower control arm, front bolt	155	114	-
Lower control arm, rear bolt and nut	155	114	-
Stabilizer bar bushing retainer screws	45	33	-
Stabilizer bar link nuts	88	65	-
Steering gear heat shield mounting screws	8	6	71
Strut body/tower mounting nuts	28	21	250
Strut clevis-to-knuckle nuts	88 plus an additional 90° (¼ turn)	65 plus an additional 90° (¼ turn)	-
Strut rod nut	65	48	-
Tie rod end-to-knuckle nut	75	55	-
Tie rod steering arm nut	75 plus an additional 245°	55 plus an additional 245°	-
Wheel mounting nuts	135	100	-

Frame Tightening Specifications

Component	Nm	ft-lb	in-lb
ABS ICU mounting bracket-to-cross member screws	50	37	-
Front engine mount cross member mounting bolts	60	44	-
Front fore/aft cross member forward mounting bolt	113	83	-
Front fore/aft cross member rearward mounting bolts	55	41	-
Front suspension cross member mounting bolts	163	120	-
Front suspension cross member support bracket mounting bolts	54	40	-
Rear engine mount cross member mounting bolts	55	41	-

Drive Axle Tightening Specifications

Component	Nm	ft-lb	in-lb
Heat shield bolts	14	-	124
Hub nut	160	118	-
Intermediate bearing-to-block bolts (10 mm)	38	28	-
Mid-shaft bearing-to-block bolts (8 mm)	23	17	-
Strut damper-to-steering knuckle bolts	88	65	-
Wheel mounting nuts	135	100	-

Rear Suspension

Fastener Tightening Specifications

Component	Nm	ft-lb	in-lb
Axle parking brake cable bracket bolts	6	-	55
Axle trailing arm bracket-to-body bolts	54	40	-
Axle trailing arm pivot through bolt	175	129	-
Brake caliper adapter mounting bolts	100	74	-
Hub and bearing mounting bolts	55	41	-
Shock absorber lower mounting bolt	75	55	-
Shock absorber upper mounting bolt	75	55	-
Track bar mounting bolt/nut	81	60	-
Wheel mounting nuts	135	100	-

Suspension,
Wheels, Steering

Wheels, Tires, Wheel Alignment

Wheel Specifications

Component	Specification
Wheel mounting (lug) nut hex size	19 mm
Wheel mounting stud size	M12 x 1.5 mm

Fastener Tightening Specifications

Component	Nm	ft-lb	in-lb
Tire Pressure Monitor (TPM) sensor nut	4.5	—	40
Tire Pressure Monitor (TPM) transponder mounting nut	3	—	27
Valve core	0.5	—	4
Wheel mounting nut	135	100	—

Wheel Alignment Data

Wheel Alignment Specified Values

All specifications are given in degrees.

All wheel alignments are to be set at curb height.

Front wheel alignment	Preferred setting	Acceptable range
Camber - left	+0.35°	-0.05° to +0.75°
Camber - right	+0.05°	-0.35° to +0.45°
Cross-camber (maximum side-to-side difference)	+0.30°	-0.20° to +0.80°
Caster ¹⁾	+2.50°	+1.50° to +3.50°
Cross-caster (maximum side-to-side difference)	0.00°	-0.75° to +0.75°
Total toe ²⁾	+0.26°	+0.06° to +0.46°
Rear wheel alignment	Preferred setting	Acceptable range
Camber ¹⁾	-0.06°	-0.46° to +0.34°
Cross-camber (maximum side-to-side difference)	0.00°	-0.25° to +0.25°
Total toe ^{1) 2)}	+0.10°	-0.15° to +0.35°
Thrust angle	0.00°	-0.30° to +0.30°

¹⁾ For reference only. These are non-adjustable angles.

²⁾ Total toe is the sum of both the left and right wheel toe settings. Total toe must be equally split between each front wheel to ensure the steering wheel is centered after setting toe. Positive toe is toe-in and negative toe is toe-out.

Steering

Fastener Tightening Specifications

Component	Nm	ft-lb	in-lb
Gear heat shield mounting screws	8	6	71
Gear mounting bolts	75	55	-
Hose tube-to-gear nut	31	23	275
Hose tube-to-pump nut	31	23	275
Inner tie rod	88	65	-
Pump mounting bolts			
- Without heat shield	23	17	200
- With heat shield	25	18	-
Pressure hose routing clamp-to-front suspension cross member screws	8	-	71
Pressure hose routing clamp-to-rear cradle screw	8	-	71
Reservoir mounting screw	12	9	106
Return hose routing cradle clamp-to-ABS support bracket screw	8	-	71
Tie rod steering arm nut	75	55	-
Tie rod jam nut	75	55	-
Intermediate shaft coupling pinch bolt	42	31	-
Intermediate shaft extension pinch bolt	42	31	-
Steering Column Control Module (SCCM) mounting screws	3	-	27
Steering column mounting nuts	28	21	250
Steering wheel retaining bolt	50	37	-

BRAKE SYSTEM

Anti-lock Brake System (ABS)

Fastener Tightening Specifications

Component	Nm	ft-lb	in-lb
ABS ABM mounting screws (to HCU) From 2012 my	3	—	27
ABS ICU mounting bolt (to bracket)	11	8	97
ABS ICU mounting pins	11	8	97
ABS ICU mounting bracket screws (to cross member)	50	37	—
ABS front wheel speed sensor knuckle routing bracket screw	8	6	71
ABS front wheel speed sensor strut routing bracket screw	10	7	89
ABS wheel speed sensor head mounting bolt	6	4.5	53
Adjustable pedal position sensor mounting screws	1.5	—	13
Brake hose bracket bolt	18	13	160
Brake hose caliper banjo bolt	24	18	212
Brake shield mounting screws	8	6	71
Brake tube nuts	14	10	120
Disc brake caliper bleeder screw	10	7	89
Front disc brake caliper adapter mounting bolts	169	125	—
Disc brake caliper adapter mounting bolts - rear	100	74	—
Front disc brake caliper guide pin bolts	35	26	—
Master cylinder mounting nuts	25	19	225
Parking brake lever mounting nuts	28	21	250
Pedal bracket upper mounting nuts	28	21	250
Power brake booster mounting nuts	28	21	250
Rear disc brake caliper adapter mounting bolts	100	74	—
Rear disc brake caliper guide pin bolts	35	26	—
Rear parking brake cable routing clamp screws	6	4.5	53
Wheel mounting nuts	135	100	—

Mechanical Components

Fastener Tightening Specifications

Component	Nm	ft-lb	in-lb
ABS ABM mounting screws (to HCU)	2	—	17
ABS ICU mounting bolt (to bracket)	11	8	97
ABS ICU mounting pins	11	8	97
ABS ICU mounting bracket screws (to crossmember)	50	37	—
ABS front wheel speed sensor knuckle routing bracket screw	8	6	71
ABS front wheel speed sensor strut routing bracket screw	10	7	89
ABS wheel speed sensor head mounting bolt	6	4.5	55
Adjustable pedal position sensor mounting screws	1.5	—	13
Brake tube nuts	14	10	120
Brake hose bracket bolt	18	13	160
Brake hose caliper banjo bolt	24	18	212
Brake shield mounting screws	8	6	71
Disc brake caliper adapter mounting bolts - front	169	125	—
Disc brake caliper adapter mounting bolts - rear	100	74	—
Disc brake caliper guide pin bolts - front	35	26	—
Disc brake caliper guide pin bolts - rear	35	26	—
Disc brake caliper bleeder screw	10	7	88
Master cylinder mounting nuts	25	19	225
Parking brake switch	2.5	—	24
Pedal bracket upper mounting nuts	28	21	250
Power brake booster mounting nuts	28	21	250
Parking brake lever mounting nuts	28	21	250
Rear parking brake cable routing clamp screws	6	4.5	55
Wheel mounting nuts	135	100	—

Brake Rotor Specifications

NOTE: When resurfacing a rotor, maintain the required total indicator reading and thickness variation limits. Extreme care in the operation of machining equipment is required.

Limits/Specifications

Brake Rotor	Rotor Thickness	Minimum Rotor Thickness	Rotor Runout ¹⁾
Front	27.87-28.13 mm	26.4 mm	0.050 mm
	1.097-1.107 in.	1.040 in	0.002 in.
Rear	11.75-12.25 mm	10.4 mm	0.050 mm
	0.463-0.482 in.	0.409 in.	0.002 in.

¹⁾ Total Indicator reading (measured on vehicle).

Hydraulic Components

Fastener Tightening Specifications

Component	Nm	ft-lb	in-lb
ABS ABM Mounting Screws (to HCU)	3	—	27
ABS ICU Mounting Bolt (to bracket)	8	—	71
ABS ICU Mounting Pins	11	8	97
ABS ICU Mounting Bracket Screws (to crossmember)	50	37	—
ABS Front Wheel Speed Sensor Knuckle Routing Bracket Screw	8	6	71
ABS Front Wheel Speed Sensor Strut Routing Bracket Screw	10	7	89
ABS Wheel Speed Sensor Head Mounting Bolt	6	4.5	55
Adjustable Pedal Position Sensor Mounting Screws	1.5	—	13
Brake Tube Nuts	23	17	204
Brake Hose Bracket Bolt	18	13	160
Brake Hose Caliper Banjo Bolt	24	18	212
Brake Shield Mounting Screws	8	6	71
Disc Brake Caliper Adapter Mounting Bolts - Front	169	125	—
Disc Brake Caliper Adapter Mounting Bolts - Rear	100	74	—
Disc Brake Caliper Guide Pin Bolts - Front	35	26	—
Disc Brake Caliper Guide Pin Bolts - Rear	35	26	—
Disc Brake Caliper Bleeder Screw	10	7	88
Electric Vacuum Pump, 3.6L Engine	55	41	—
Master Cylinder Mounting Nuts	25	19	225
Pedal Bracket Upper Mounting Nuts	28	21	250
Power Brake Booster Mounting Nuts	28	21	250
Parking Brake Lever Mounting Nuts	28	21	250
Rear Parking Brake Cable Routing Clamp Screws	6	4.5	55
Wheel Mounting Nuts	135	100	—

BODY

Body Exterior

Air Gap Body Dimensions

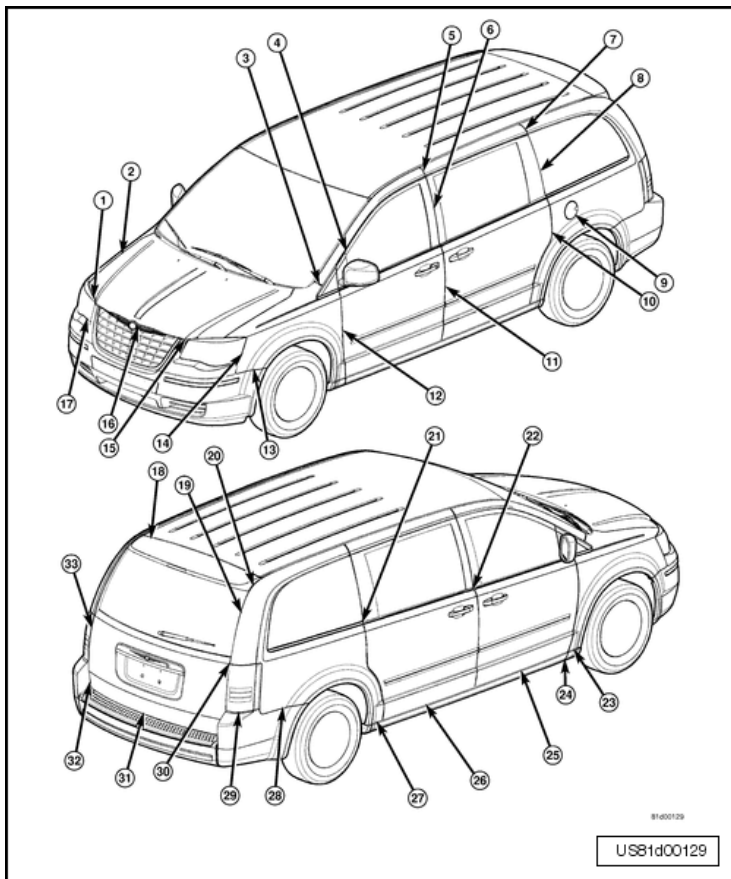

All dimensions are in millimeters.

O/F = Over Flush

U/F = Under Flush

U/D = Up/Down

F/A = Fore/Aft

Dimension	Description	Gap	Flush
1	Headlamp to hood	3.5 ± 2.3 parallel within 2.0	Headlamp U/F 1.1 ± 2.3 consistent within 2.0
2	Hood to fender	4.0 ± 1.5 parallel within 1.5 side-to-side within 1.5	Hood U/F 2.0 ± 1.5 consistent within 1.5 side-to-side within 1.5
3	Fender to body side aperture	3.8 ± 1.5 parallel within 1.5	0.0 ± 1.5 consistent within 1.5
4	Body side aperture (A-pillar) to front door header	-	A-pillar O/F ± 1.5 consistent within 1.5
5	Body side aperture (A-pillar) to sliding door (above glass)	5.5 ± 1.5	Cross car: body side aperture O/F ± 1.5
6	Front door applique to sliding door applique (above belt)	5.0 ± 2.0 parallel within 2.0	0.0 ± 2.0 consistent within 2.0
7	Sliding door to body side aperture rear (above glass)	5.0 ± 1.5	0.0 ± 1.5
8	Body side aperture glass to sliding door applique	5.0 ± 2.0 parallel within 2.0	Body Side aperture glass U/F 2.5 ± 2.0 consistent within 2.0
9	Fuel filler door to body side aperture	3.0 ± 1.5 parallel within 1.5	Fuel filler door U/F 0.5+/- 1.5 consistent within 1.5
10	Sliding door to body side aperture rear (below belt)	5.0 ± 1.5 parallel within 1.5	0.0 ± 1.5 consistent within 1.5
11	Front door to sliding door (below belt)	5.0 ± 1.5 parallel within 1.5	Front door O/F 0.5 ± 1.5 consistent within 1.5
12	Fender to front door	5.0 ± 1.5 parallel within 1.5	Fender O/F 0.5 ± 1.5 consistent within 1.5

Air Gap Body Dimensions (cont'd)

Dimension	Description	Gap	Flush
13	Fascia to fender	Vertical: Net to 1.0 horizontal: Net to 1.0	Vertical: 0.0 ± 2.0 consistent within 2.0 horizontal: 0.0 ± 2.0 consistent within 2.0
14	Headlamp to fender	Top: 2.0 +2.3/-2.0 parallel within 2.0 O/B side: 2.0 +2.3/-2.0 parallel within 2.0	Top: Headlamp U/F 1.0 ± 2.3 consistent within 2.0 O/B side: headlamp U/F 1.0 ± 2.3 consistent within 2.0
15	Fascia to hood	6.0 ± 2.0 side-to-side within 2.0	Fascia U/F 2.8 ± 2.0 side-to-side within 2.0
16	Hood to grille (at towers)	VW (Badge): 6.3 ± 2.0 side-to-side within 2.0	VW (Badge) O/F ± 2.0 side-to-side within 2.0
17	Fascia to headlamp (Inboard)	2.3	-
18	Spoiler to roof	7.5 ± 2.0 parallel within 2.0	Spoiler U/F 2.0 ± 2.0 consistent within 2.0
19	D-pillar to liftgate glass	5.0 ± 2.0 parallel within 2.0	-
20	D-pillar to spoiler	5.0 ± 2.0 parallel within 2.0	-
21	Front door to sliding door (at beltline)	5.0 ± 2.0	Front door O/F 0.5 ± 2.0
22	Sliding door to body side aperture (at beltline)	5.0 ± 2.0	0.0 ± 2.0
23	Fender to sill	4.0 ± 2.0 parallel within 2.0	Sill O/F 5.0 ± 2.0
24	Fender sill to front door sill	5.0 ± 2.0 parallel within 2.0	0.0 ± 2.0
25	Sill to front door	6.3 ± 2.0 parallel within 2.0	Sill O/F 5.0 ± 2.0 consistent within 2.0

Dimension	Description	Gap	Flush
26	Sill to sliding door	6.1 ± 2.0 parallel within 2.0	Front, sill O/F 5.5 ± 2.0 Rear, sill O/F 5.0 ± 2.0 consistent within 2.0
27	Body side aperture rear to sill	4.2 ± 2.0	Sill O/F 5.0 ± 2.0
28	Rear fascia to body side aperture	Net to 1.0	0.0 ± 2.0 consistent within 2.0
29	Rear fascia to tail lamp	3.0 ± 2.0 parallel within 2.0	Tail lamp U/F 0.5 ± 2.0 consistent within 2.0
30	Body side aperture to liftgate at feature line (diagonal corners near tail lamp)	-	Liftgate U/F 2.2 ± 1.5
31	Liftgate to fascia U/D	8.0 ± 2.0 parallel within 2.0	-
32	Liftgate to fascia cross/car	5.0 ± 2.0 parallel within 2.0 side-to-side within 2.0	-
33	Tail lamp to liftgate	5.15 ± 2.0 parallel within 2.0	Tail lamp O/F 1.9 ± 2.0 consistent within 2.0

Body Front Tightening Specifications

Component	Nm	ft-lb	in-lb
Cross member-to-body bolt	19	14	-
Cross member brace bolt	19	14	-
Fascia to fender bolt	5.5	-	49
Fender bolt	12.5	9	-
Hood latch bolt	13.5	10	-

Hood, Lids Tightening Specifications

Component	Nm	ft-lb	in-lb
Hood hinge bolt	9	-	80
Hood nut	25	18	-
Hood latch bolt	11	8	-
Liftgate bolt	33	24	-
Liftgate handle nut	3	-	22

Hood, Lids Tightening Specifications (cont'd)

Component	Nm	ft-lb	in-lb
Liftgate hinge nut	33	24	-
Liftgate latch screw	11	-	95
Liftgate lock cylinder nut	3	-	22
Liftgate striker screw	28	21	-
Liftgate strut pivot	33	24	-
Power liftgate drive unit bolt	29	21	-
Power liftgate drive unit motor screw	6	-	53
Power liftgate pinch sensor screw	1.5	-	13
Striker bolt	9	-	80

Front Doors, Central Locking System Tightening Specifications

Component	Nm	ft-lb	in-lb
Door hinge bolt	33	24	-
Door latch screw	3	-	27
Door latch striker screw	28	21	-
Exterior door handle bolt	5	-	44

Rear Doors Tightening Specifications

Component	Nm	ft-lb	in-lb
Center hinge screw	13	-	115
Drive tension bolt	14.5	-	130
Front catch striker bolt	24	-	21
Hold open latch nut	5	-	45
Hold open striker bolt	10	-	90
Lower roller arm bracket bolt	13	-	115
Power sliding door drive nut	9	-	80
Side impact sensor screw	9	-	80
Stabilizer socket screw	4	-	33
Upper roller arm bolt	13	-	115

Sunroof Tightening Specifications

Component	Nm	ft-lb	in-lb
Glass panel screw	3.5	-	31
Sunroof motor bolt	3	-	26

Bumpers Tightening Specifications

Component	Nm	ft-lb	in-lb
Front bumper reinforcement nut	27	20	-
Front fascia bolt	5.5	-	49
Rear bumper extension bolt	95	70	-
Rear bumper reinforcement nut	27	20	-
Rear fascia bolt	5.5	-	49

Window Regulators Tightening Specifications

Component	Nm	ft-lb	in-lb
Window regulator motor screw	2.8	-	25
Window regulator screw	9	-	80

Exterior Equipment Tightening Specifications

Component	Nm	ft-lb	in-lb
Fascia-to-fender bolt	5.5	-	49
Fascia-to-upper core support bolt	5.5	-	49
Luggage rack nut	35	26	-
Outside rearview mirror bolt	20	-	177

Body Interior

Interior Equipment Tightening Specifications

Component	Nm	ft-lb	in-lb
HVAC control screw	2	-	17
Instrument panel center support bracket bolt	9	-	80
Knee bolster bolt	4	-	35

Passenger Protection, Airbags, Seat Belts Fastener Tightening Specifications

Component	Nm	ft-lb	in-lb
DAB and floating horn switch-to-steering wheel armature screws	13	10	-
KAB mounting plate-to-support screws	3	-	28
KAB mounting plate-to-KAB housing nuts	6	-	53
Occupant restraint controller bolt	10	-	89
Passenger airbag bracket bolt	6	-	53
Seat airbag-to-seatback frame nut	10	-	88

Passenger Protection, Airbags, Seat Belts Fastener Tightening Specifications (*cont'd*)

Component	Nm	ft-lb	in-lb
Seat belt buckle lower anchor bolt/nut	39	29	-
Seat belt guide bolt	39	29	-
Seat belt height adjuster bolt	39	29	-
Seat belt lower anchor bolt/nut	39	29	-
Seat belt retractor bolt	39	29	-
Seat belt web lower guide bolt	9	-	80
Side curtain airbag bracket nut	7	-	62
Side curtain airbag nut	7	-	62
Side impact sensor screw	9	-	80

Interior Trim Tightening Specifications

Component	Nm	ft-lb	in-lb
A/C suction and liquid lines-to-A/C expansion valve nut	23	17	-
HVAC air inlet housing-to-passenger side dash panel bolt	3	-	27
HVAC housing-to-engine compartment side dash panel	3	-	27
Instrument panel-to-cowl side bolt	14	-	120
Instrument panel center support bracket bolt	9	-	80
Instrument panel-to-dash panel bolt	9	-	80
Knee bolster bolt	4	-	35

Seat Frames Tightening Specifications

Component	Nm	ft-lb	in-lb
Armrest bracket bolt	10	-	89
Armrest-to-seat back bolt	29	21	-
Crosstalk tube protect bracket-to-recliner screw	2.5	-	22
Forward/back motor bolt	5	-	44
Front tilt motor bolt	12	-	106
Front tilt motor gearbox spindle bolt	17	-	150
Height adjust motor bolt	12	-	106
Height adjust motor gearbox spindle bolt	17	-	150
Plastic grocery bag retainer screw	2	-	17
Power folding stow motor bolt	27	19	-

Component	Nm	ft-lb	in-lb
Power folding stow motor gear cover screw	3.5	-	31
Power seat track-to-front seat cushion bolts	28	21	-
Recliner motor bolt	9	-	80
Seat-to-floor panel bolt (third row)	58	43	-
Seat back-to-seat bolt	27	19	-
Seat back frame bolt (second row buckets)	48	35	-
Seat back recliner-to-seat frame bolt (second row buckets)	55	40	-
Seat back-to-seat back hinge bolt	48	35	-
Seat back-to-seat track pivot bolt	48	35	-
Seat belt anchor-to-seat bolt	48	35	-
Seat back hinge cover screw	2.3	-	20
Seat back hinge bolt	48	35	-
Seat bracket-to-floor panel nut (second row buckets)	54	40	-
Seat cushion frame-to-seat riser nut (second row bucket)	30	22	-
Seat cushion frame-to-seat riser nut (bench seat)	48	35	-
Seat hinge-to-floor panel bolt (third row)	89	66	-
Seat track-to-floor panel nut (front seats)	88	65	-
Seat track-to-riser nut (second row buckets)	45	33	-
Seat track-to-seat cushion frame bolt	28	21	-
Seat riser-to-seat track bolt/nut	48	35	-
Under seat storage bin guide screw	3.6	-	32
Under seat storage bin latch screw	2	-	18

Seat Upholstery, Covers Tightening Specifications

Component	Nm	ft-lb	in-lb
Seat cushion-to-seat riser bolt (bench)	40	29.5	-
Seat track-to-seat cushion frame bolt (front seat)	28	21	-

HEATING, VENTILATION AND AIR CONDITIONING

Heating, Ventilation

Fastener Tightening Specifications

Description	Nm	in-lb
All fasteners not listed below	1.2	10
A/C compressor-to-engine	Specific fastener placement and torque pattern is required. Refer to ElsaWeb, <i>Removal and Installation</i> .	
Blend door actuator	1.2	10
Blower motor power module	1.2	10
Defroster duct screws	2	17
Front HVAC control screws	2	17
Front HVAC housing screws	3	27
Front mode door actuator	1.2	10
Heater core tube clamps	1.7	15
Instrument panel air outlet screws	2	18
Instrument panel duct screws	2	18

Auxiliary Heating

Fastener Tightening Specifications

Description	Nm	ft-lb	in-lb
All screws not listed below	1.2	-	11
Defroster duct screws	2	-	17
Liquid refrigerant lines to A/C receiver/drier bolts	13.5	-	120
Rear A/C expansion valve bolts	11	-	97
Rear blower motor screws	2	-	17
Rear expansion valve refrigerant line nut	11	-	97
Rear HVAC housing bolts	3	-	27
Rear HVAC housing screws	2	-	17
Rear heater core tubes bracket screw	2	-	17
Rear heater core tubes-to-floor panel nuts	3	-	27
Rear heater core tubes-to-inner quarter panel bolt	3	-	27
Refrigerant lines-to-underbody refrigerant line nut	23	17	-

Air Conditioning

Refrigerant Charge Capacity

Application	Capacity
Front A/C only	0.82 kg (1.81 lbs)
Front and rear A/C	1.15 kg (2.53 lbs)

Fastener Tightening Specifications

Description	Nm	ft-lb	in-lb
All screws not listed below	1.2	-	11
A/C compressor-to-engine bolts	23	17	-
A/C compressor to engine nuts	40	30	-
A/C compressor shaft bolt	19	-	168
Front A/C expansion valve bolts	11	-	97
Front HVAC housing, bolts	3	-	27
Liquid refrigerant lines-to-A/C receiver/drier bolts	13.5	-	120
Receiver/drier-to-frame rail bolt	9	-	80
Refrigerant lines-to-A/C compressor nuts	23	17	-
Refrigerant lines-to-A/C condenser nuts	23	17	-
Refrigerant lines-to-front expansion valve nut	20	15	-
Refrigerant lines-to-rear expansion valve nut	11	-	97
Refrigerant lines-to-underbody refrigerant line nut	23	17	-
Service port valve caps	0.6	-	5
Service port valve core (high side)	2.3	-	20
Service port valve core (low side)	0.4	-	4
Suction line-to-compressor	20	15	-
Suction line-to-frame rail bolt	9	-	80

ELECTRICAL SYSTEM

Electrical Equipment

Battery, Starter, Generator and Cruise Control Tightening Specifications

Component	Nm	ft-lb	in-lb
Battery hold down bolt	7	-	62
Battery terminal clamp pinch bolt hex nut	5	-	45
Battery tray bolts	12	-	105
Battery tray nut	12	-	105
Engine mount bracket retainers	55	41	-
Engine mount through bolt	61	45	-
Generator B+ nut	13	10	115
Generator decoupler	110	81	-
Generator output terminal stud nut	14	-	125
Negative battery cable eyelet terminal-to-inner fender bolt	12	9	-
Negative battery cable ground eyelet terminal-to-engine block bolt	16.5	-	145
Remote start antenna bolts	2.5	-	22
Starter bolt	47	35.5	-
Starter solenoid positive cable nut	14.5	-	128
Starter solenoid B+ terminal stud nut	13	-	115
Totally Integrated Power Module (TIPM) B+ terminal stud nut	10	-	89

Battery Specifications

Battery Classifications and Ratings				
BCI group size classification	Cold cranking amperage	Reserve capacity	Ampere - hours	Load test amperage
H7	700	140 Minutes	80	350

Windshield Wiper/Washer Tightening Specifications

Component	Nm	ft-lb	in-lb
Front wiper arm nut	30	22	-
Front wiper motor screw	12	9	-
Rear wiper arm nut	10	-	89
Rear wiper motor nut	10	-	89
Windshield washer reservoir screw	11	-	97
Windshield wiper module bolt	8	-	71

Wiring Tightening Specification

Component	Nm	ft-lb	in-lb
Totally Integrated Power Module (TIPM) nut	11	-	97

Volkswagen Group of America works constantly to develop and improve its products. We must therefore reserve the right to change or update any part of this technical manual at any time. No legal commitment can therefore be derived from the information, illustrations or descriptions in this manual.

The texts, illustrations and standards in this manual are based on the information available at the time of printing. No part of this manual may be reprinted, reproduced or translated without the written permission of Volkswagen Group of America.

All rights under the copyright laws are expressly reserved by Volkswagen Group of America. Subject to alteration and amendment.

**Printed in the United States of America
© 2013 Volkswagen Group of America, Inc.**

