

Subject: DRIVER-SIDE MIRROR VIBRATION WHEN DRIVING ON ROUGH ROAD OR HIGHWAY	Bulletin No: 09-044/12
	Last Issued: 11/20/2012

BULLETIN NOTE

- This bulletin supersedes the previous bulletin 09-009/11, issued on 07/27/2011 and 03/01/2011. The REPAIR PROCEDURE, has been revised.
- Changes are noted below in Red beside the change bar.

APPLICABLE MODEL(S)/VINS

2010-2012 CX-9

DESCRIPTION

Some vehicles may exhibit a vibration on the driver-side rear view mirror (A) when driving on a rough road or highway. The mirror vibration may get worse when vehicle speed is over 65mph (105Km/h). During these conditions, customers may complain that the driver-side rear view mirror is difficult to see.

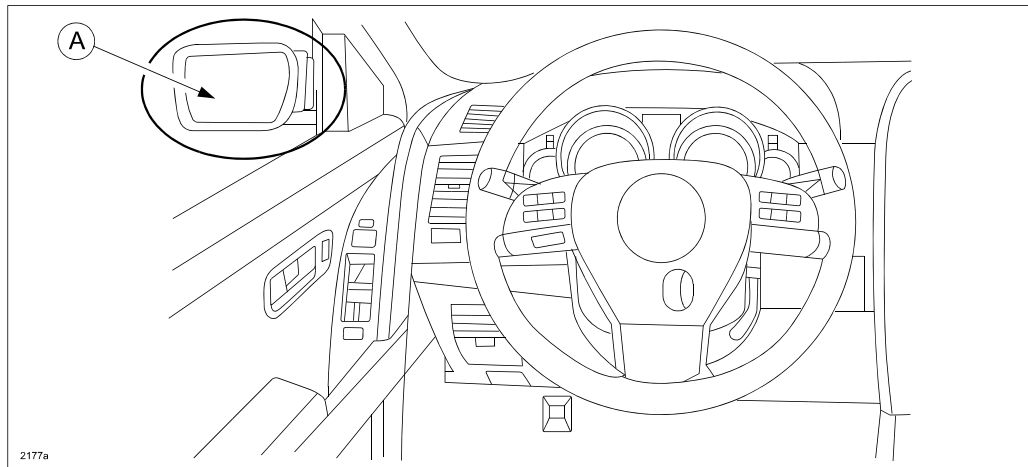

The following repair procedures have been developed to reduce vibration concern.

REPAIR PROCEDURE REMOVAL	Outer mirror removal	Page 2
REPAIR PROCEDURE INSTALLATION	Installation of corner bracket and new outer mirror	Page 5

CONSUMER NOTICE: The information and instructions in this bulletin are intended for use by skilled technicians. Mazda technicians utilize the proper tools/equipment and take training to correctly and safely maintain Mazda vehicles. These instructions should not be performed by "do-it-yourselfers." Customers should not assume this bulletin applies to their vehicle or that their vehicle will develop the described concern. To determine if the information applies, customers should contact their nearest authorized Mazda dealership. Mazda North American Operations reserves the right to alter the specifications and contents of this bulletin without obligation or advance notice. All rights reserved. No part of this bulletin may be reproduced in any form or by any means, electronic or mechanical---including photocopying and recording and the use of any kind of information storage and retrieval system ---without permission in writing.

REPAIR PROCEDURE

Removal

1. Record radio stations and remove the negative battery terminal.
2. Remove the outer mirror glass (A) from mirror body. Refer to MS3 online or Workshop Manual (section 09-12 OUTER MIRROR GLASS REMOVAL).

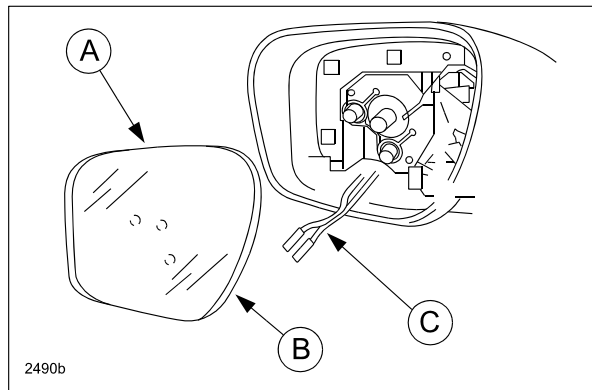

Outer mirror glass	A
Mirror glass holder	B
Heated outer mirror connector	C

3. Detach the outer mirror garnish clips (A) then remove outer mirror garnish (B).

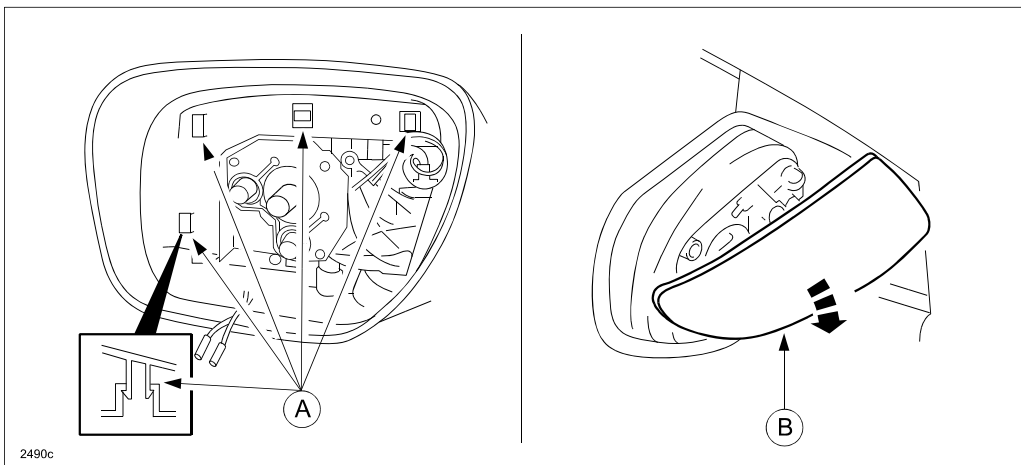

NOTE:

- Mirror garnish clip locations (A) may vary.
- Outer mirror garnish (B) will be reused.

4. Remove the inner garnish (A). Refer to MS3 online or Workshop Manual (section 09-17 INNER GARNISH REMOVAL/INSTALLATION).
5. Remove the front door trim (B). Refer to MS3 online or Workshop Manual (section 09-17 FRONT DOOR TRIM REMOVAL/INSTALLATION).

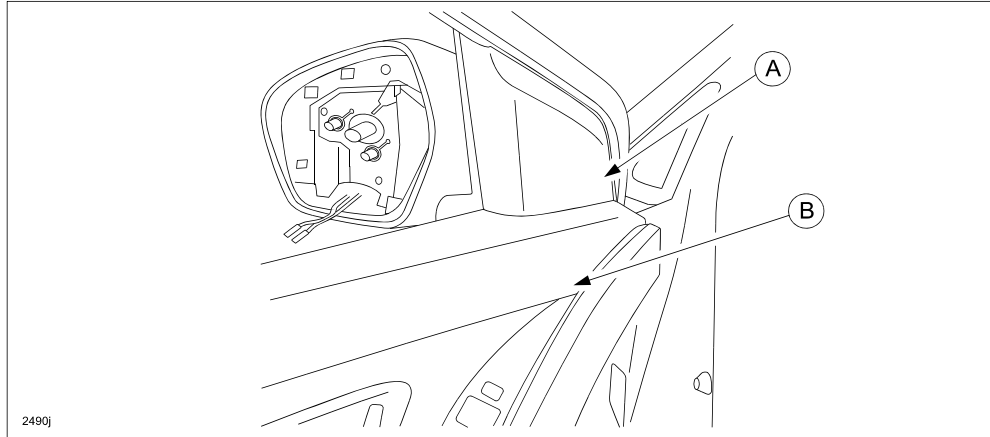

6. Disconnect the outer mirror connector.
7. Remove the outer mirror by removing and discarding the 3 bolts (A).

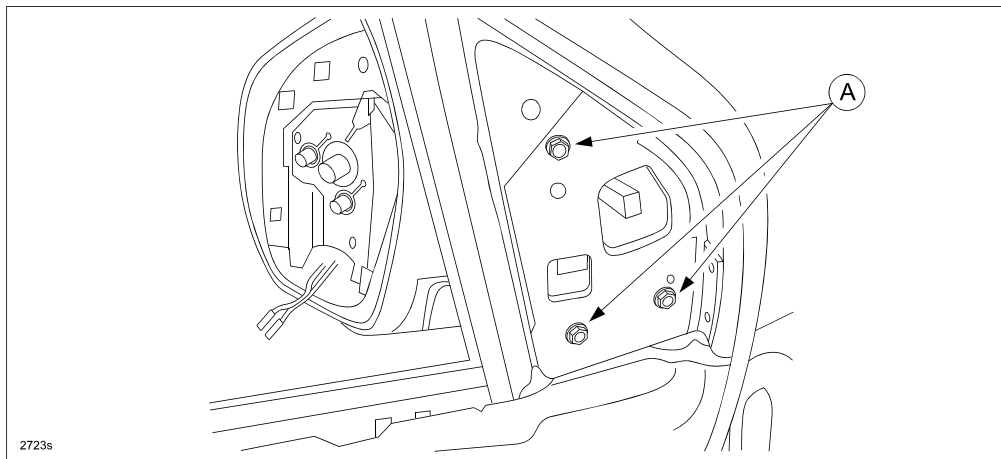

8. Remove and retain the foam piece.

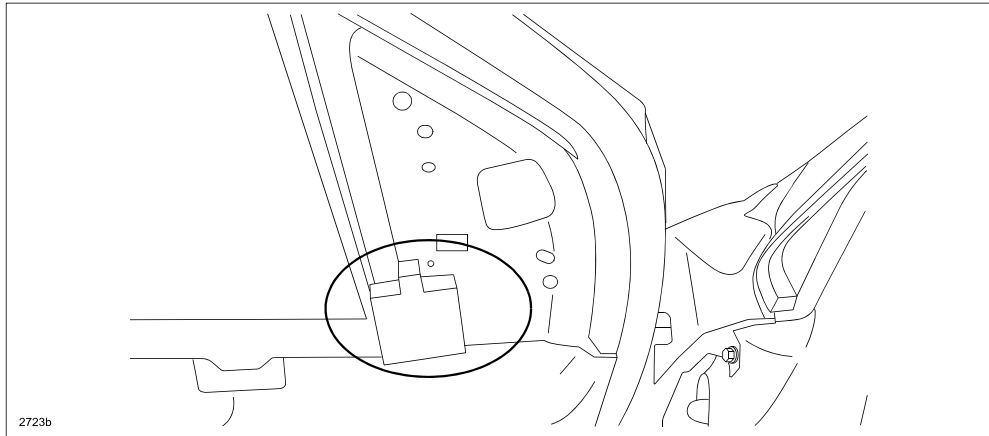

9. Cover the interior side of the door panel.

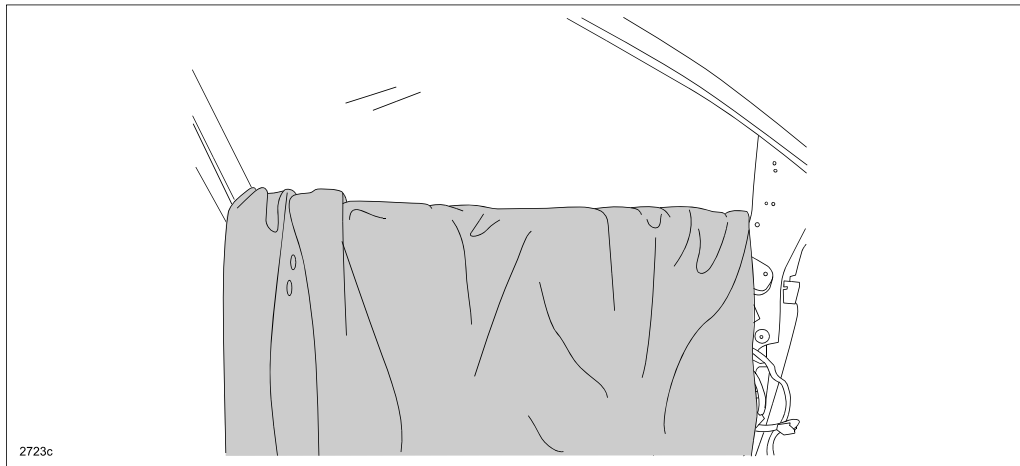

Installation

1. Flip over the reinforcement bracket from the Corner Bracket Kit so that the “ears” (A) are facing downwards.
2. Using the roloc disc pad assembly (3M® 05539) and surface conditioning disc (3M® 7480), sand the reinforcement bracket to bare metal as shown.

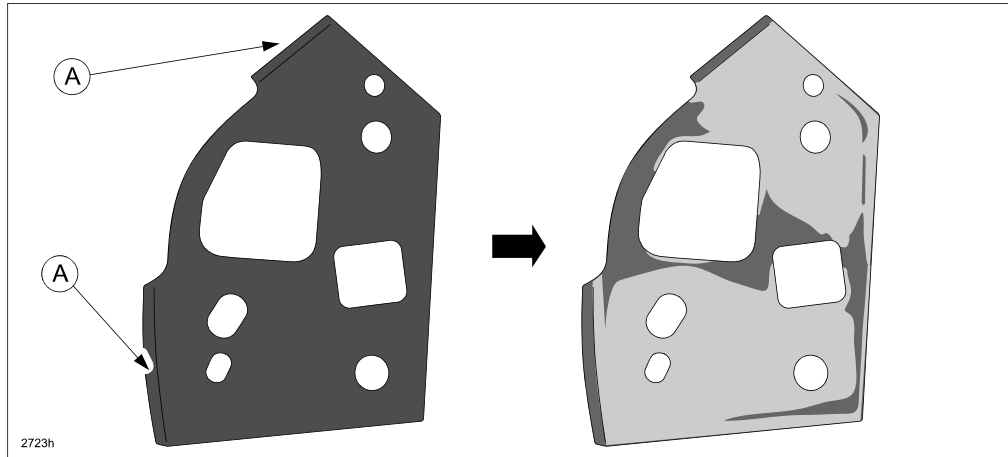

CAUTION: Make sure to wear safety goggles and latex gloves.

3. Momentarily place the reinforcement bracket onto the door pillar. Align the holes to the holes of the door pillar. Place (3) pieces of masking tape outlining the bracket edges as shown.

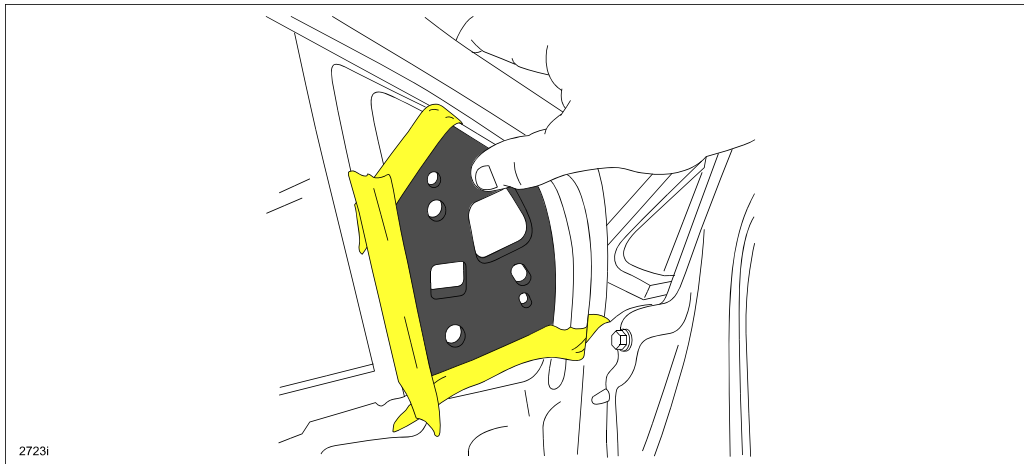

4. Remove the reinforcement bracket.

- Using the roloc disc pad assembly (3M® 05539) and surface conditioning disc (3M® 7480), sand the door pillar to bare metal as shown.

NOTE: Wear safety goggles and latex gloves.

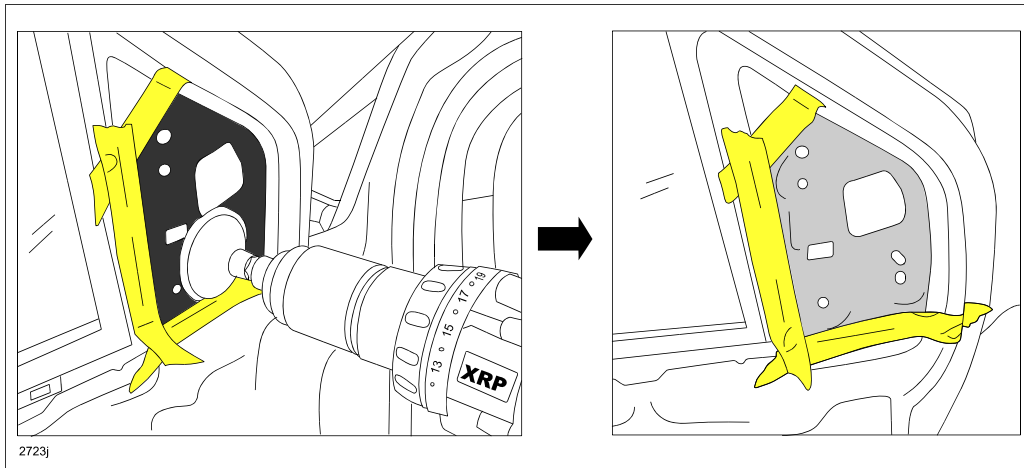

- Using isopropyl alcohol and a shop rag, clean the sanded area of the reinforcement bracket and door pillar.

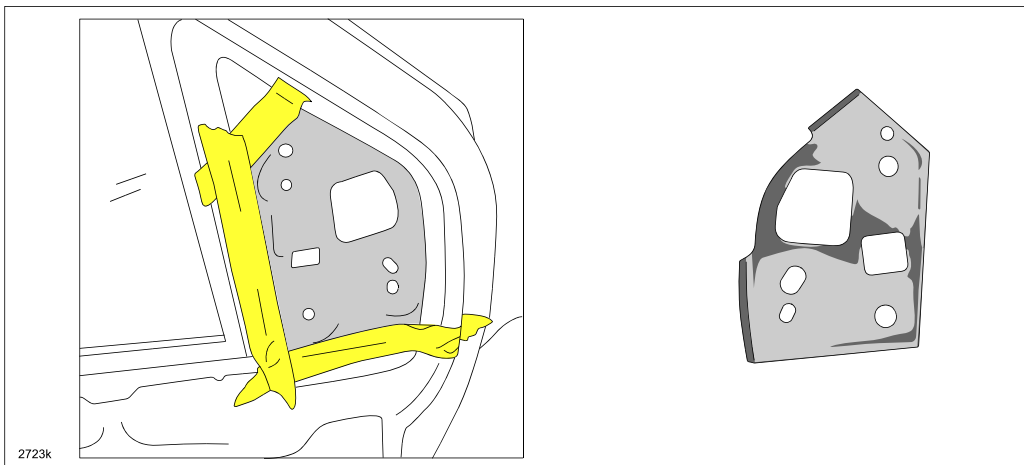

NOTE: It will not be necessary to apply paint primer on the sanded areas as the panel bonding adhesive (3M® 38315) already contains primer.

Prepare the applicator gun (3M® 08190) by:

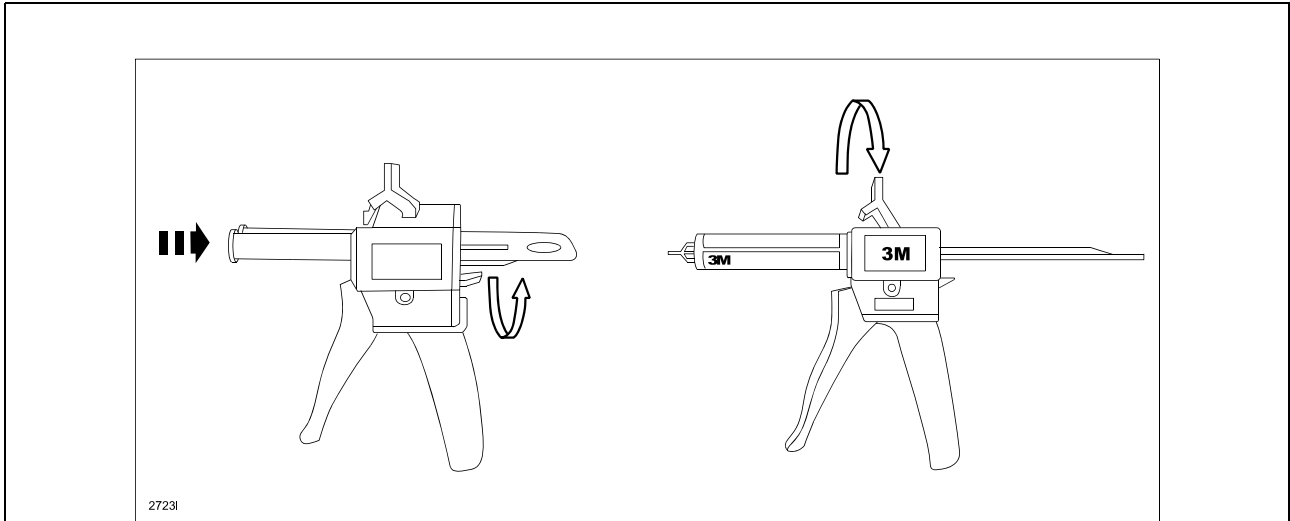

A. While holding the metal lock tab upwards, insert the rail and slide it rearwards.

B. Slide the panel bonding adhesive (3M® 38315) onto the applicator gun and lock the tab.

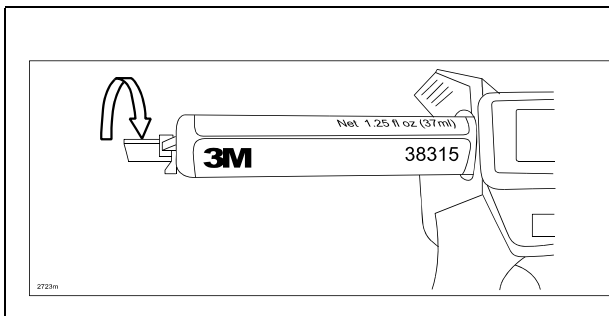

C. Twist off the sealing cap from the panel bonding cartridge.

Note: Do not discard the sealing cap.

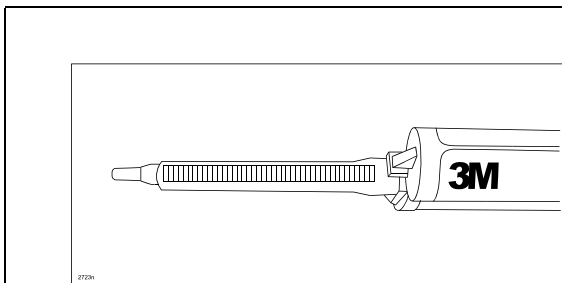

D. Twist on the nozzle onto the panel bonding cartridge.

7. On a scrap piece of paper or cardboard, prime the panel bonding (3M® 38315) until a solid black color is obtained.

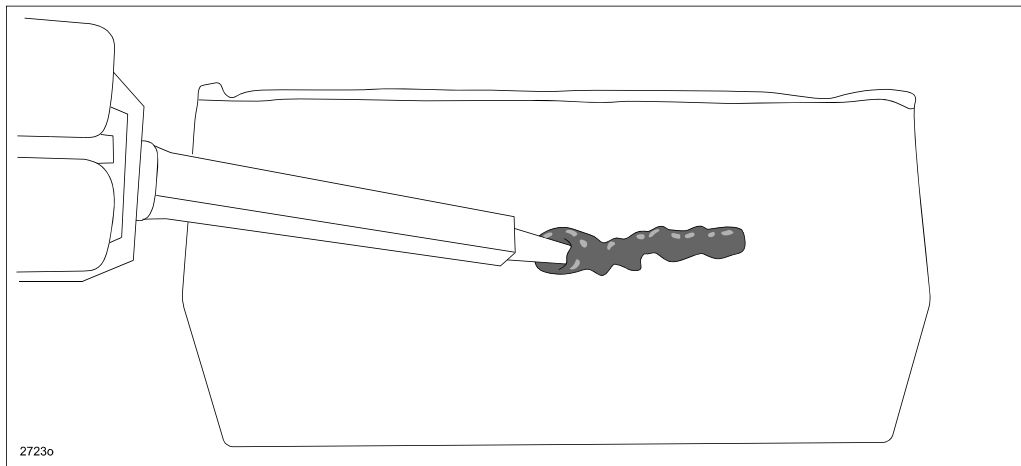

8. Dispense panel bonding material (3M® 03815) onto the entire reinforcement bracket. Use the spreader to spread the material, leaving a 1/16" minimum thickness.

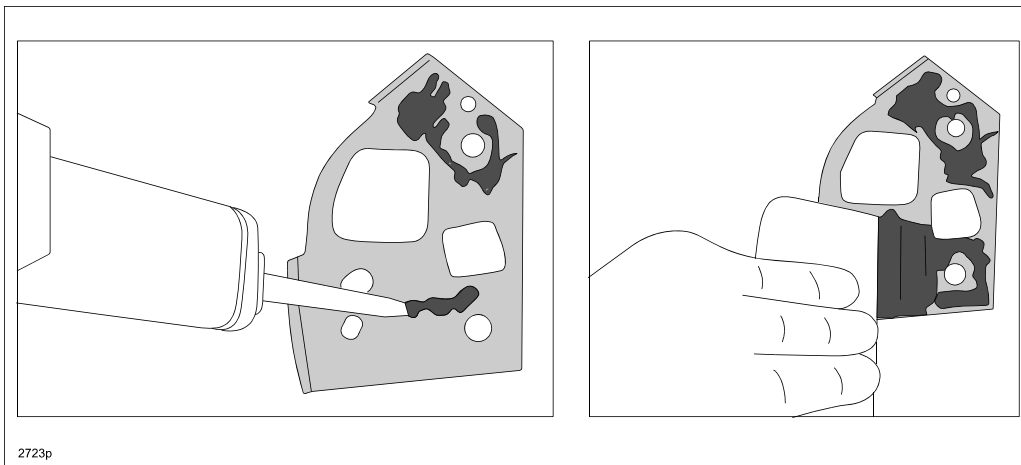

9. Remove excess panel bonding material (3M® 38315) from the holes.

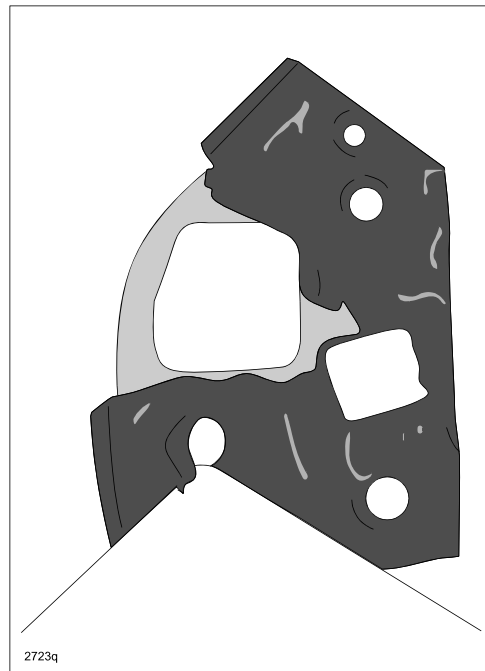

10. Dispense panel bonding material (3M® 03815) onto the sanded area of the door pillar. Spread the material, leaving a 1/16" minimum thickness.

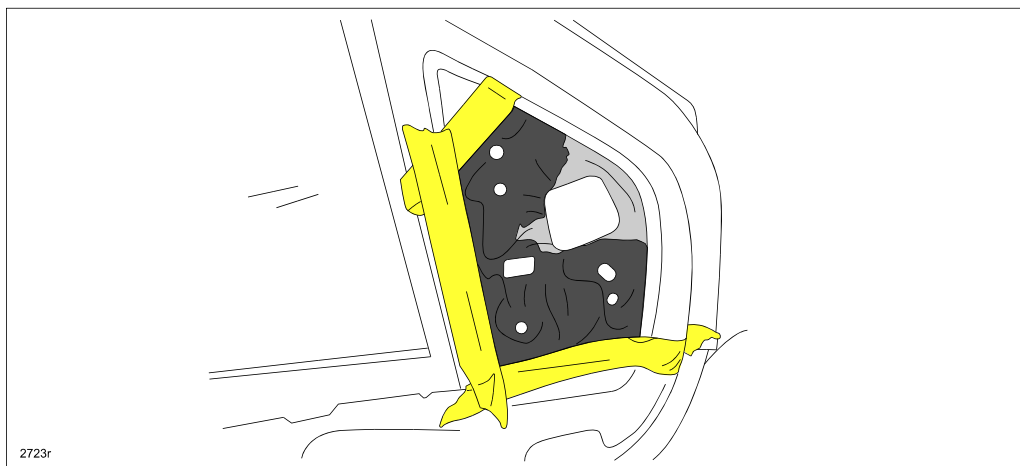

11. Place the reinforcement bracket onto the door pillar.

12. While holding the reinforcement bracket in place, install the new outer mirror and tighten the (3) new bolts (A) to 3.5-5.0 Nm (36-51 kgfcm 31-44 in-lb).

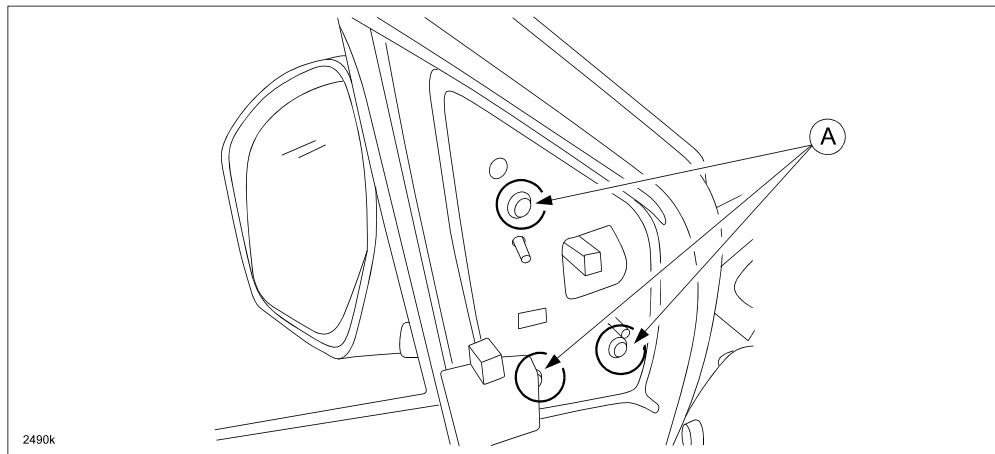

13. Use a shop rag to wipe off excess panel bonding material.

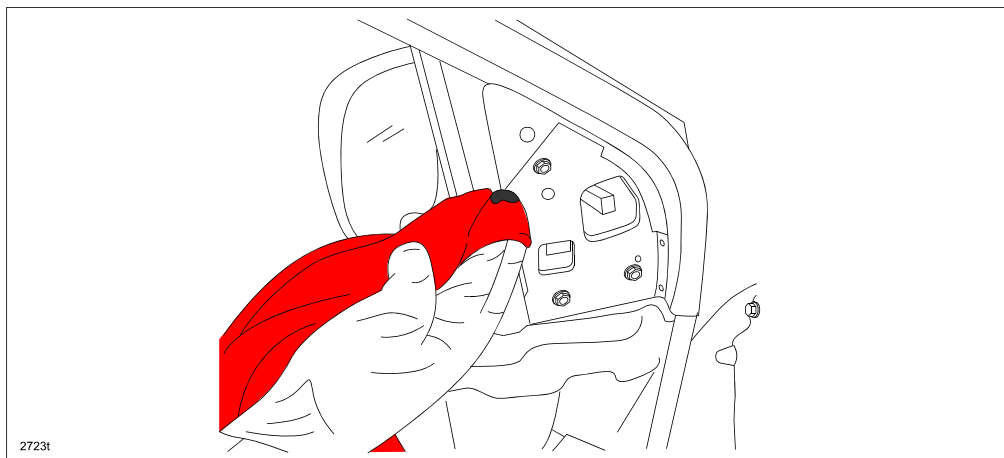

14. Reinstall the foam piece (A) and electrical connector (B).

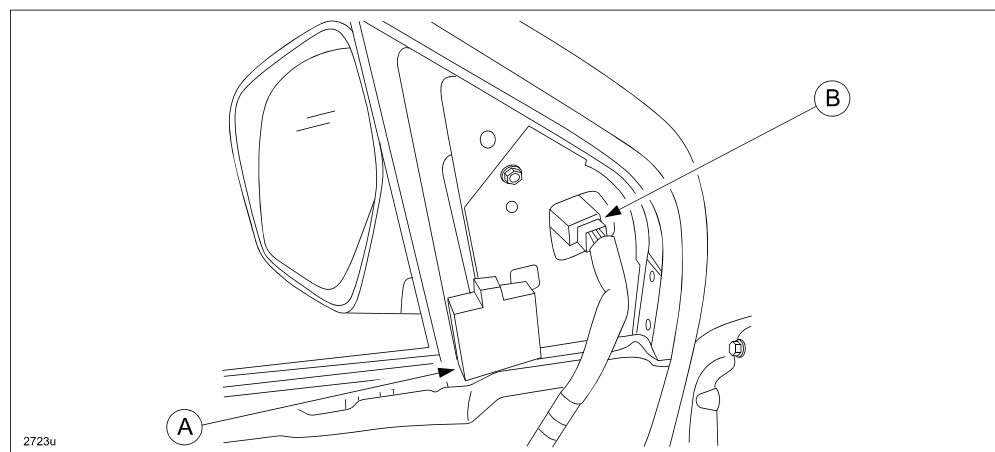

15. Install the removed parts (outer mirror glass, outer mirror garnish, inner garnish, and front door trim) in reverse order.
16. Connect the negative battery terminal and reset radio stations.
17. Let the panel bonding material cure (initial curing for (4) hours). After the initial curing, the vehicle can be returned to the customer.
NOTE: The panel bonding adhesive will fully cure in 24 hours. For proper curing of the panel bonding adhesive, the ambient temperature must be at least 73 F (22.7 degrees C).
18. Remove and discard the applicator nozzle, then reinstall the sealing cap (previously removed) onto the panel bonding adhesive.
NOTE: The shelf life of the panel bonding adhesive is (1) year when stored at room temperature.
19. Verify smooth power mirror operation before releasing the vehicle to the customer.

For addition information (Safety / Health information) regarding the 3M® panel bonding adhesive, please contact 3M®.

(651) 737-6501

www.3M.com/automotive

PART(S) INFORMATION

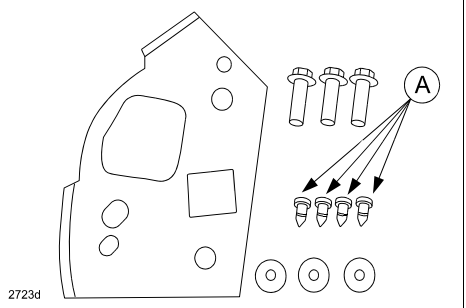
Part Number	Description	Qty	Notes
TEY1-59-187	Corner Bracket Kit	1	 <p>For driver side door (A) - Do not use (may be discarded)</p>
TE69-69-18ZG	Outer Mirror	1	Base mirror
TE70-69-18ZG	Outer Mirror	1	With heater
TE71-69-18ZJ	Outer Mirror	1	With heater and turn lamp
TE72-69-18ZJ	Outer Mirror	1	With heater, turn lamp, and BSM
Locally sourced	Applicator gun and rail	1	3M® 08190
Locally sourced	Panel bonding adhesive and 1 mixing nozzle	1	3M® 38315 (will repair 6 vehicles)
Locally sourced	Surface conditioning discs (medium) approx. 180 grit	1	3M® 7480
Locally sourced	Roloc disc pad assembly (used with "C" surface conditioning discs	1	3M® 05539

To obtain 3M® products, refer to: www.3Mcollision.com

NOTE: A package of (12) mixing nozzles can be obtained by ordering 3M® part number 03191.

WARRANTY INFORMATION

NOTE:

- This warranty information applies only to verified customer complaints on vehicles eligible for warranty repair.
- This repair will be covered under Mazda's New Vehicle Limited Warranty term.
- Additional diagnostic time cannot be claimed for this repair.

Warranty Type	A
Symptom Code	83
Damage Code	9W
Part Number Main Cause	Use Outer Mirror Part Number from PARTS INFORMATION
Quantity	1
Operation Number / Labor Hours:	XXH7BXRX / 0.6 Hrs