

Maintenance for HV & Auxiliary Batteries

Service
 Category General

Section Pre-Delivery Service

Market USA

Toyota Supports
 ASE Certification 

Applicability

YEAR(S)	MODEL(S)	ADDITIONAL INFORMATION
2013	Prius, Prius C, Prius PHV, Prius V	

Introduction

Prius vehicles are equipped with 2 types of batteries:

- Hybrid Vehicle (HV) battery
- 12-volt auxiliary battery

If Prius vehicles are put into storage, the state of charge (SOC) of its HV battery and auxiliary battery will gradually decrease. To prevent the auxiliary battery from becoming discharged during storage, proper maintenance is necessary.

Please perform the following maintenance service for the HV battery and 12-volt auxiliary battery.

NOTE

- Before disconnecting the auxiliary battery, confirm the shift lever is in the "P" position and apply the parking brake completely. The shift lever CANNOT be shifted from the "P" position with the 12-volt auxiliary battery disconnected.
- If the negative (-) terminal of the auxiliary battery is reconnected, even if the power button is in the "START" mode, the hybrid system may NOT start. In this case, push the "POWER" button and select the "START" mode again to start the hybrid system (the "READY" light is ON). If the hybrid system still does NOT start (the "READY" light is OFF), refer to the Repair Manual.

Warranty Information

OP CODE	DESCRIPTION	TIME	OFP	T1	T2
N/A	Not Applicable to Warranty	-	-	-	-

Maintenance for HV & Auxiliary Batteries

Maintenance Items

CONDITION*	MAINTENANCE OPERATION
Before Delivery	Fully charge 12-volt auxiliary battery (deliver the vehicle to the customer after it is fully charged 12.6 V or more).
To Store for 30 Days or More	Disconnect the negative (-) terminal of the 12-volt auxiliary battery in the luggage compartment to prevent the SOC of the auxiliary battery from decreasing during storage due to parasitic current.
Just After Unloading & Every 2 Months	Keep the Hybrid System ON for 30 minutes with the transmission in the "P" position (in order to charge the HV battery and the auxiliary battery).

* The condition also corresponds with the section titles within this TSB.

Required Tools & Equipment

SPECIAL SERVICE TOOLS (SST)	PART NUMBER	QTY
GR8 Battery Diagnostic Station*	<u>00002-MCGR8</u>	1

* Essential SST.

NOTE

The GR8 Battery Diagnostic Station (P/N 00002-MCGR8) supersedes the Automatic Trickle Charger (P/N 00002-YA122-01) and Fast Battery Chargers (Associated P/N ASE6003 and Christie P/N CAPPDQ). P/N 00002-YA122-01, ASE6003, and CAPPDQ are now obsolete.

Maintenance for HV & Auxiliary Batteries

Before Delivery

Fully charge the 12-volt auxiliary battery:

1. Before charging the auxiliary battery, turn OFF all lights, accessories, and the hybrid system.
2. Open the back door and remove the battery cover.
3. Remove the positive (+) terminal cover.

Figure 1.

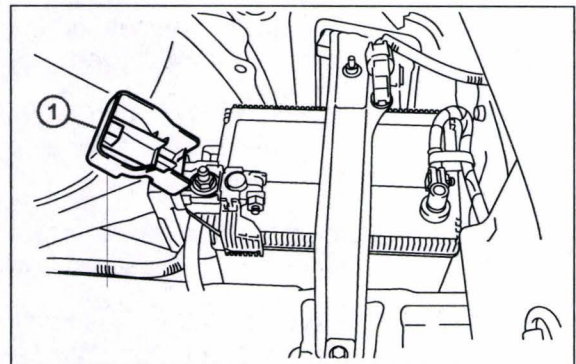

1 Positive Terminal

4. Check the battery SOC.
 - If the battery voltage is LESS THAN 12.6 V, then continue to step 5.
 - If the battery voltage is 12.6 V or MORE, replace the positive (+) terminal cover, install battery cover and close the back door.

NOTE

- If measuring the voltage with the negative (-) terminal connected, turn OFF the power switch and turn ON the headlights for 20 to 30 seconds. This will remove the surface charge from the battery.
- If the engine has been running before measuring the voltage, wait 20 minutes or more after the engine stops. This removes the surface charge.

Maintenance for HV & Auxiliary Batteries

Before Delivery

Fully charge the 12-volt auxiliary battery: (Continued)

5. Test/charge the 12-volt auxiliary battery using the GR8 Battery Diagnostic Station. Figure 2.

- A. Connect the red charger clamp to the positive (+) battery terminal and the black charger clamp to the negative (-) battery terminal.
- B. Plug the charger into a grounded 110-volt nominal outlet and flip the power switch to the "ON" position.
- C. Once the charger is properly turned ON, perform a diagnostic charge.

The GR8 Battery Diagnostic Station will indicate result when complete.

If the battery tests bad ("Replace Battery"), then replace the auxiliary battery.

NOTE

If the auxiliary battery was stored at 32°F (0°C) or below, charge the auxiliary battery in a room above 32°F (0°C).

CAUTION

- Charge in a well-ventilated area.
- Do NOT allow sparks or fire near the auxiliary battery.

If the GR8 Battery Diagnostic Station is NOT available, you may charge the 12-volt battery by cycling the vehicle on to "READY."

- Run time will vary depending on the state of charge.
- If this method is used, you must confirm that the battery is charged to 12.8 volts using a DVOM.

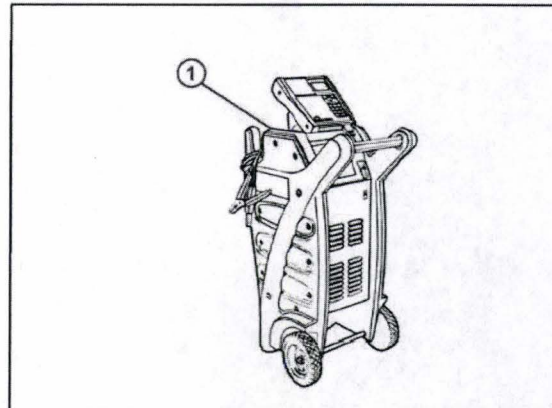

1

P/N 00002-MCGR8

Maintenance for HV & Auxiliary Batteries

Before Delivery

Fully charge the 12-volt auxiliary battery: (Continued)

6. After charging the auxiliary battery, install the positive (+) terminal cover.

Figure 3.

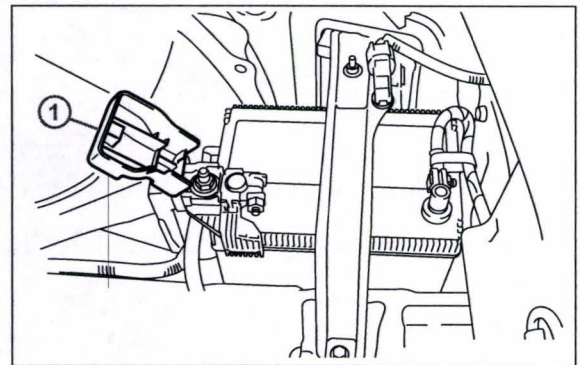

1	Positive Terminal
---	-------------------

7. Install the battery cover and close the back door.

To Store for 30 Days or More

Disconnect the negative (-) terminal:

1. Turn OFF all lights, accessories, and the hybrid system.
2. Open back door and remove the battery cover
3. Disconnect the negative (-) terminal.

Figure 4.

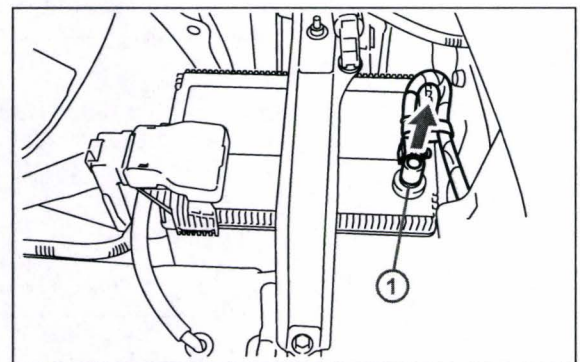

1	Negative Terminal
---	-------------------

Maintenance for HV & Auxiliary Batteries

To Store for 30 Days or More

Disconnect the negative (-) terminal: (Continued)

4. Install the battery cover and close the back door.

NOTE

When it is necessary to move the vehicle, reconnect the negative (-) terminal.

When removing the vehicle from storage, connect the negative (-) terminal:

1. Open the back door and remove the battery cover.
2. Connect the negative (-) terminal.

Torque: 6.0 N*m (61 kgf*cm, 4.4 ft*lbf)

Figure 5.

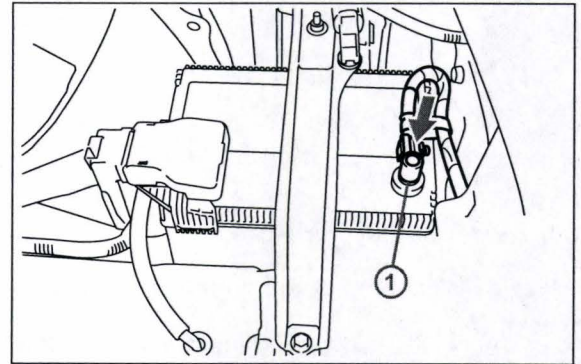

1 Negative Terminal

3. Install the battery cover and close the back door.

NOTE

After recharging the auxiliary battery, the hybrid system may NOT start. Follow the procedure below to initialize the system.

- Put the shift lever in the "P" position.
- Open and close any of the doors.
- Restart the hybrid system.

Maintenance for HV & Auxiliary Batteries

Every Two Months

Cycle vehicle to "READY" ON:

NOTE

- When the remaining capacity of the HV battery is low, the gasoline engine automatically starts and the HV battery is charged by the generator. The 12-volt auxiliary battery is also charged by the HV battery regardless of the gasoline engine operation.
- Be sure to reconnect the negative (-) terminal of the auxiliary battery BEFORE performing this procedure.

1. Park the vehicle in open air or connect the exhaust extraction hose to the exhaust pipe.
2. Apply the parking brake.
3. With the brake pedal depressed, push the "POWER" button and select the "START" mode and check that the "READY" light in the meter illuminates when the hybrid system starts (the "READY" light is ON).

Figure 6.

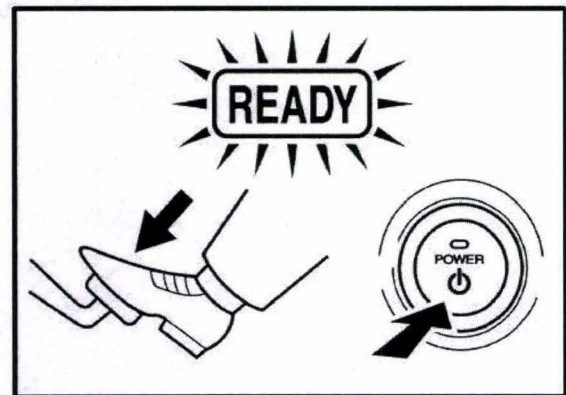

4. Turn OFF all lights and accessories.
5. Check that the shift lever is in the "P" position.
6. Keep the "READY" light on and charge the HV battery for 30 minutes.

NOTE

- If the amount of charging energy is small, the display may NOT indicate the energy flow.
- Ensure there is a sufficient amount of fuel for the vehicle to run for 30 minutes.