

# Maintenance for EV & Auxiliary Batteries

Service  
Category General

Section Pre-Delivery Service

Market USA

Scion Supports  
ASE Certification 

## Applicability

YEAR(S)	MODEL(S)	ADDITIONAL INFORMATION
2013	iQ EV	

## Introduction

The iQ EV is equipped with 2 types of batteries:

- Electric Vehicle (EV) Traction Battery
- 12-volt Auxiliary Battery

If the iQ EV is put into storage, the state of charge (SOC) of the EV battery and auxiliary battery will gradually decrease. To prevent the auxiliary battery from becoming discharged during storage, proper maintenance is necessary.

Please perform the following maintenance service for the EV battery and 12-volt auxiliary battery.

### NOTE

- **Before disconnecting the auxiliary battery, confirm the shift lever is in the "P" position and apply the parking brake completely. The shift lever CANNOT be shifted from the "P" position with the 12-volt auxiliary battery disconnected.**
- **When the negative (-) terminal of the auxiliary battery is reconnected, the EV system may not operate if the vehicle is already in "Ready On" state. If this occurs, push the Start/Stop switch to re-initiate the "Ready On" mode. The "Ready" light should illuminate on the Instrument Panel. If the EV system will not "Ready On", refer to the Repair Manual for diagnosis.**

## Warranty Information

OP CODE	DESCRIPTION	TIME	OFF	T1	T2
N/A	Not Applicable to Warranty	-	-	-	-

## Maintenance for EV & Auxiliary Batteries

### Maintenance Items

CONDITION*	MAINTENANCE OPERATION
Before Delivery	Fully charge 12-volt auxiliary battery (deliver the vehicle to the customer after it is fully charged 12.6 V or more).
To Store for 30 Days or More	Disconnect the negative (-) terminal of the 12-volt auxiliary battery under the hood to prevent the SOC of the auxiliary battery from decreasing during storage due to parasitic current.
Just After Unloading & Every 2 Months	Fully charge EV battery using vehicle charging station.

\* The condition also corresponds with the section titles within this bulletin.

### Required Tools & Equipment

SPECIAL SERVICE TOOLS (SST)	PART NUMBER	QTY
GR8 Battery Diagnostic Station**	<u>00002-MCGR8</u>	1

\*\* Essential SST.

**NOTE**

The GR8 Battery Diagnostic Station (P/N 00002-MCGR8) supersedes the Automatic Trickle Charger (P/N 00002-YA122-01) and Fast Battery Chargers (Associated P/N ASE6003 and Christie P/N CAPPDQ). P/N 00002-YA122-01, ASE6003, and CAPPDQ are now obsolete.

## Maintenance for EV & Auxiliary Batteries

### Before Delivery

#### Fully charge the 12-volt auxiliary battery:

1. Before charging the auxiliary battery, turn OFF vehicle, lights, and accessories.
2. Open the hood.

Figure 1.

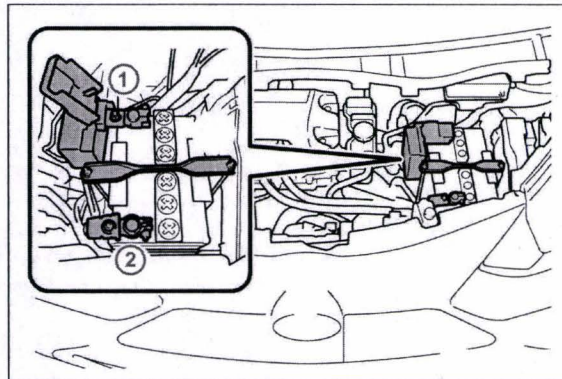

1	Positive Battery Terminal
2	Negative Battery Terminal

3. Remove the positive (+) terminal cover.
4. Check the battery SOC.
  - If the battery voltage is LESS THAN 12.6 V, then continue to step 5.
  - If the battery voltage is 12.6 V or MORE, replace the positive (+) terminal cover and close the hood.

**NOTE**

**If measuring the voltage with the negative (-) terminal connected, turn vehicle OFF and turn ON the headlights for 20 to 30 seconds. This will remove the surface charge from the battery.**

5. Test/charge the 12-volt auxiliary battery using the GR8 Battery Diagnostic Station.
  - A. Connect the red charger clamp to the positive (+) battery terminal and the black charger clamp to the negative (-) battery terminal.
  - B. Plug the charger into a grounded 110-volt nominal outlet and flip the power switch to the "ON" position.

## Maintenance for EV & Auxiliary Batteries

### Before Delivery

#### Fully charge the 12-volt auxiliary battery: (Continued)

C. Once the charger is properly turned ON, perform a diagnostic charge.

The GR8 Battery Diagnostic Station will indicate result when complete.

If the battery tests bad ("Replace Battery"), then replace the auxiliary battery.

**NOTE**

If the auxiliary battery was stored at 32°F (0°C) or below, charge the auxiliary battery in a room above 32°F (0°C).

**CAUTION**

- Charge in a well-ventilated area.
- Do NOT allow sparks or fire near the auxiliary battery.

If the GR8 Battery Diagnostic Station is NOT available, you may charge the 12-volt battery by cycling the vehicle on to "READY:"

- Run time will vary depending on the state of charge.
- If this method is used, you must confirm that the battery is charged to 12.8 volts using a DVOM.

6. After charging the auxiliary battery, install the positive (+) terminal cover.

Figure 2.

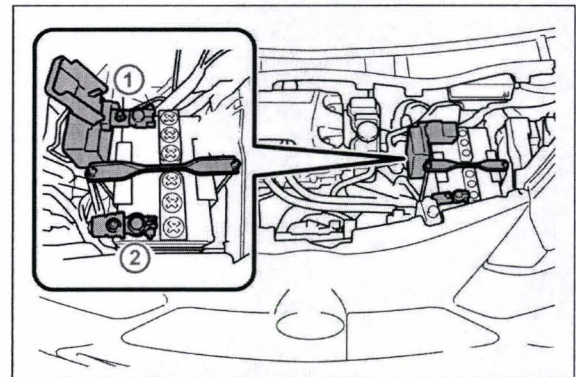

1	Positive Battery Terminal
2	Negative Battery Terminal

7. Close the hood.

## Maintenance for EV & Auxiliary Batteries

### To Store for 30 Days or More

#### Disconnect the negative (-) terminal:

1. Turn OFF vehicle, lights, and accessories.
2. Open the hood.
3. Disconnect the negative (-) terminal.

Figure 3.

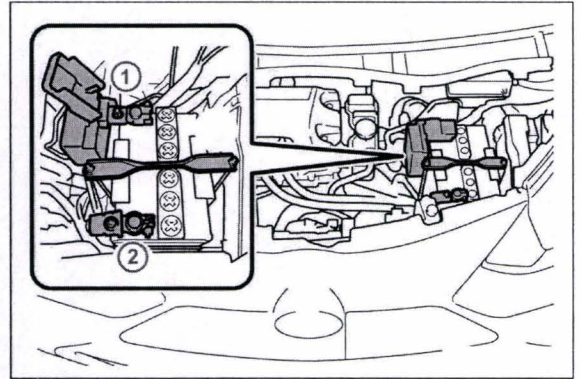

1	Positive Battery Terminal
2	Negative Battery Terminal

4. Close the hood.

**NOTE**

**When it is necessary to move the vehicle, reconnect the negative (-) terminal.**

## Maintenance for EV & Auxiliary Batteries

### To Store for 30 Days or More (Continued)

When removing the vehicle from storage, connect the negative (-) terminal:

1. Open the hood.
2. Connect the negative (-) terminal.  
**Torque: 6.0 N\*m (61 kgf\*cm, 4.4 ft\*lbf)**

Figure 4.

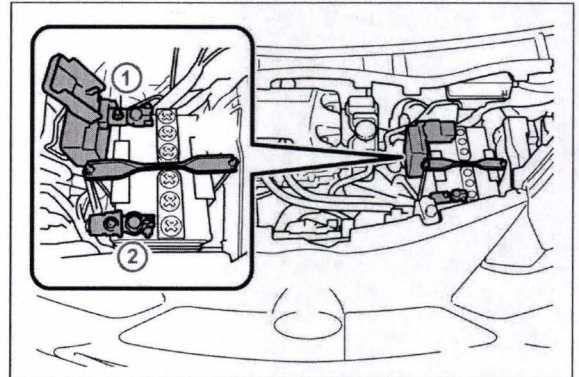

1	Positive Battery Terminal
2	Negative Battery Terminal

3. Close the hood.

**NOTE**

When the negative (-) terminal of the auxiliary battery is reconnected, the EV system may not operate if the vehicle is already in "Ready On" state. If this occurs, push the Start/Stop switch to re-initiate the "Ready On" mode. The "Ready" light should illuminate on the Instrument Panel. If the EV system will not "Ready On" refer to the repair manual for diagnosis.

## Maintenance for EV & Auxiliary Batteries

### Every Two Months

**NOTE**

Be sure to reconnect the negative (-) terminal of the auxiliary battery BEFORE performing this procedure.

1. Park the vehicle next to the EV Charging Station.
2. Apply the parking brake.
3. Turn OFF vehicle, lights, and accessories.
4. Check that the shift lever is in the "P" position.
5. Connect the charging station plug to the vehicle. Fully charge EV battery.

Figure 5.

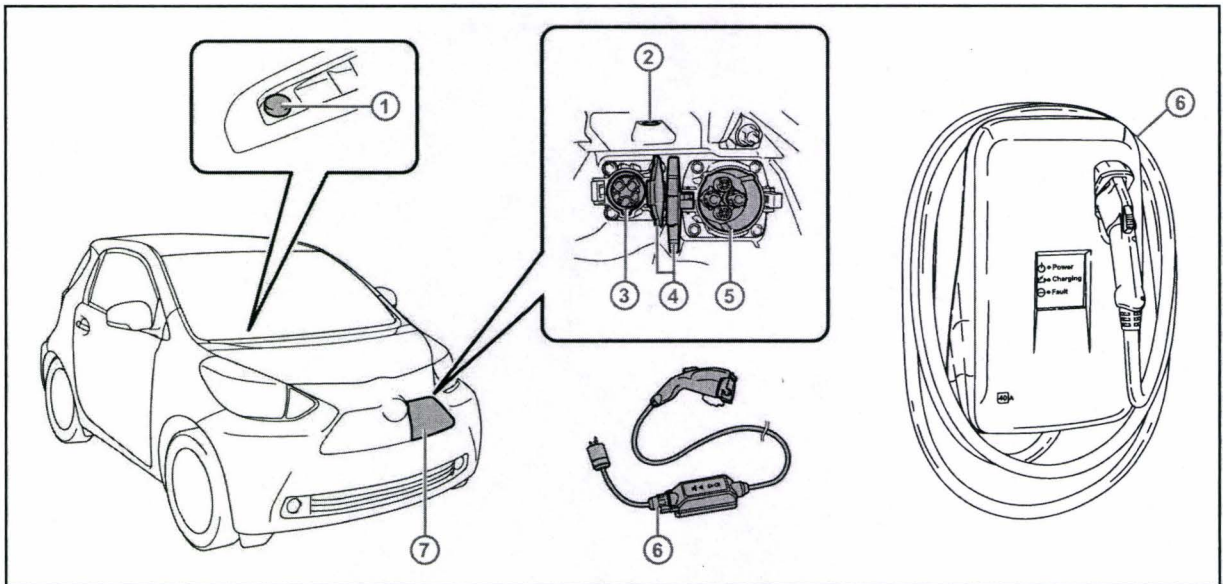

1	Charging Cable with CCID (in trunk)
2	Charging Indicator
3	Charging Port Door

4	Charging Port Cap
5	Charging Port
6	EV Charging Station