

SERVICE BULLETIN



M-1322

April 3, 2012

SECURING CVO SOFTAIL AND FLD SADDLEBAGS

Purpose

Harley-Davidson has received reports of saddlebags accidentally becoming unsecured on certain Dyna and Softail motorcycles. Investigation revealed the cause was due to improper attachment. Harley-Davidson Service wishes to reiterate the saddlebag installation instructions contained in the Owner's Manual to increase dealer and customer awareness to prevent improperly attached saddlebags.

We will also take this opportunity to review proper latching of the saddlebag lids.

Vehicles Affected

This information applies to all 2012 Dyna FLD and 2010-2012 Softail CVO models.

Markets Affected

All markets are affected.

Required Dealer Action

We believe this situation can be resolved with increased dealer and customer awareness. Dealers are to place a copy of the appropriate following two pages in the saddlebags of affected vehicles. During new vehicle orientation, the dealer is to present

the customer with the instruction sheet and demonstrate how to correctly secure the saddlebags.

A thin film of grease applied to the rubber docking bushings will ease installation. Use SPECIAL PURPOSE GREASE or plumber's silicone faucet grease available from hardware stores.

Always pull on the saddlebag after latching to confirm it is secure. Also visually inspect between the bag and frame to confirm the bracket latch is protruding through the opening. Do not rely solely on the position of the lock knob.

If an owner of a 2010-2011 CVO Softail model is experiencing difficulty in securing saddlebags, LATCH REPAIR KIT (Part No. 88257-07B) is available at customer expense. It includes a 2012-style knob and decals for improved visual verification of latch position. Each kit will update one saddlebag.

Latching Saddlebag Lid: FLD Models

It is important that the lid be correctly latched to prevent accidental opening while the vehicle is in motion. Always confirm both lid latches are engaged by pulling up firmly on lid after closing. Explain to the customer how to correctly close and latch the saddlebag and how to confirm that both latches are engaged.

The lid latches can also be visually inspected to verify they are engaged, however they are not easily seen on 2012 Dyna FLD.

NOTE

In the interest of preserving customer safety and satisfaction, always check for outstanding recalls whenever any motorcycle is brought into your dealership for either maintenance or service.

ROUTING	SERVICE MANAGER	SALES MANAGER	PARTS MANAGER	WARRANTY PROCESS MANAGER	LEAD TECHNICIAN	TECHNICIAN NO. 1	TECHNICIAN NO. 2	TECHNICIAN NO. 3	RETURN THIS TO
INITIAL HERE									

©2012 H-D

2012 DYNA FLD

Removal

1. See Figure 2 and Figure 3. Inside the saddlebag, pull the knob and rotate to the UNLOCK position.
2. See Figure 1. Hold the saddlebag and slide it toward the rear of the motorcycle to remove it from the three docking posts.

NOTE

Once removed, saddlebags may be easily tipped if not secured in the upright position. The right saddlebag has a larger cavity along the bottom to accommodate the brackets for the exhaust system. Place saddlebags on a level surface, preferably supported against a wall or other surface. Avoid dragging the saddlebags on the ground to prevent scratches.

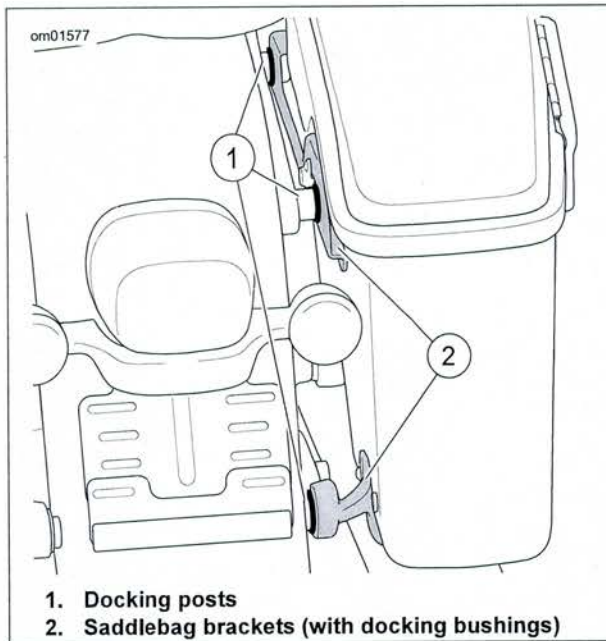

Figure 1. Saddlebag Installation: FLD Model

Installation

NOTE

If the docking bushings on the saddlebag are damaged or missing, install new bushings before mounting the saddlebags on the motorcycle.

1. See Figure 1. With the knob in the UNLOCK position, slide the saddlebag on to the motorcycle, engaging the saddlebag brackets to the three docking posts on the side of the motorcycle.
2. See Figure 2. Pull the knob and rotate to the LOCK position until the knob snaps into place.
3. Check that the saddlebag is secure on all three docking posts and the locking latch is secure. Gently pull the saddlebag to the rear to check that it is secure on the motorcycle.

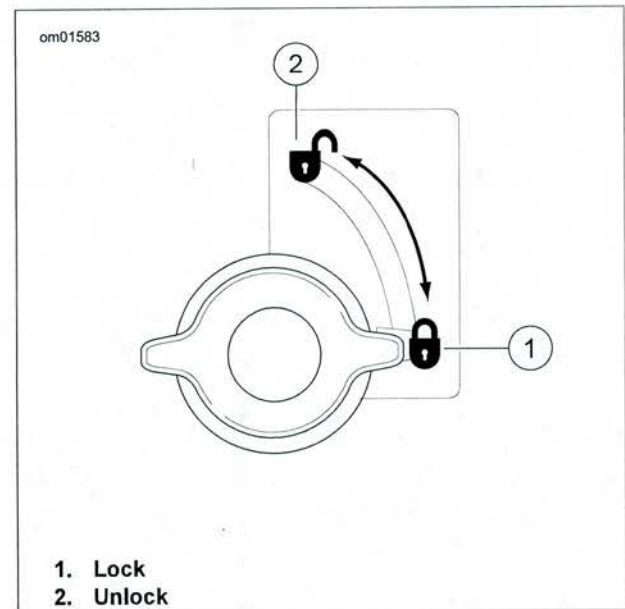

Figure 2. Saddlebag Lock Knob: FLD Model

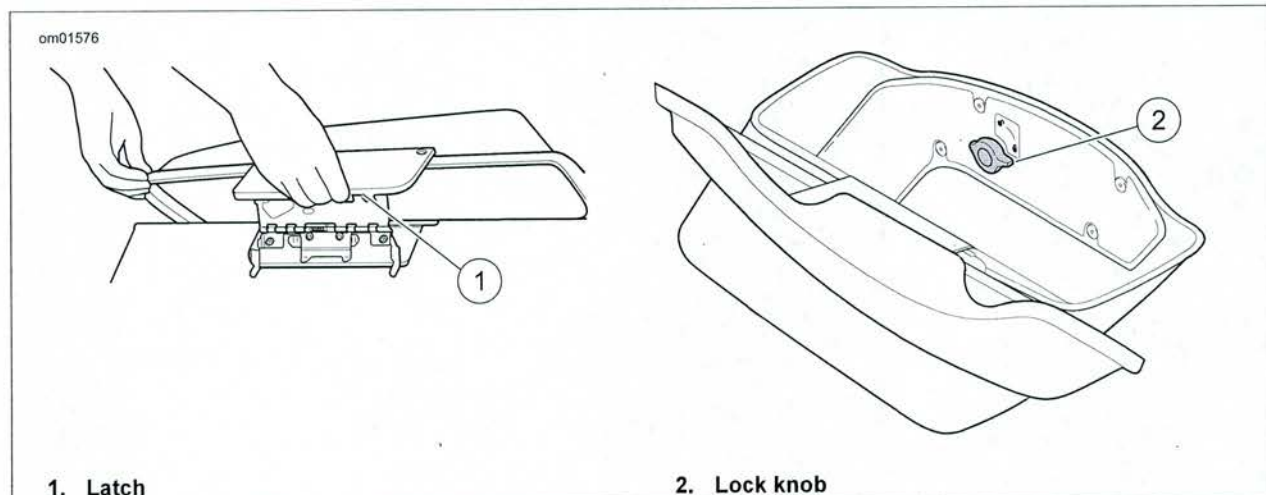

Figure 3. Saddlebag: FLD Model

2010-2012 SOFTAIL CVO

Removal

- See Figure 4. Open the saddlebag. Pull and rotate the lock knob in toward the front of the vehicle to release the bracket latch.
 - Right saddlebag:** Pull and rotate knob counterclockwise to unlock.
 - Left saddlebag:** Pull and rotate knob clockwise to unlock.
- See Figure 5. Push bag toward rear of the vehicle to disengage the saddlebag brackets from the docking points.
- Pull bag off the three docking points.

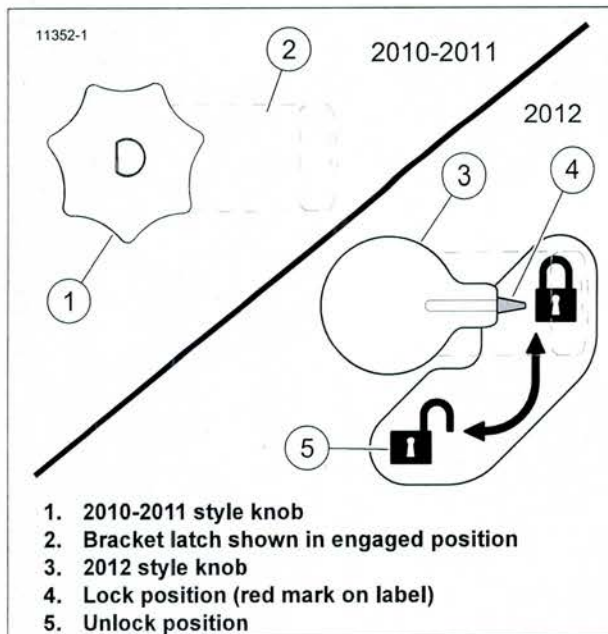

Figure 4. Saddlebag Lock Knob

Installation

- See Figure 5. Align the slots on the saddlebag mounting bracket with the two docking points on the rear fender. Insert the front bracket arm into the mounting point on the passenger footpeg bracket.
- Push the saddlebag forward to seat the brackets on to the three docking points.
- See Figure 4.

2010-2011 Models: Inside the saddlebag, rotate the lock knob to engage latch. The knob will snap into place when fully engaged.

2012 Models: Inside the saddlebag, rotate the lock knob to align the mark on the knob with the red mark on the label. The knob will snap into place and the red spacer behind the knob will be hidden as the latch is fully engaged.

 - Right saddlebag:** Rotate knob clockwise to lock.
 - Left saddlebag:** Rotate knob counterclockwise to lock.

- See Figure 6. Check that the saddlebag is secure on all mounting points and that the bracket latch is engaged as shown.

NOTICE

Check that saddlebag frame(s) are fully seated and tightly secured with mounting hardware. Failure to do so could result in the saddlebags becoming detached and/or damaged. (00171b)

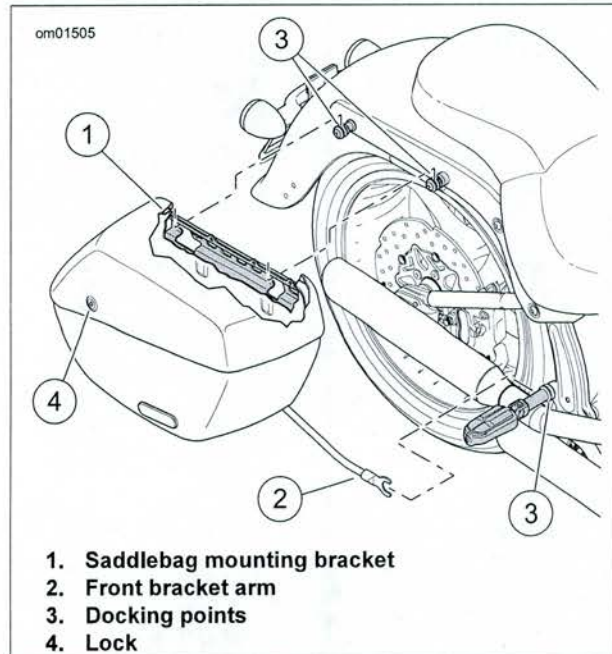

Figure 5. Saddlebag Removal/Installation

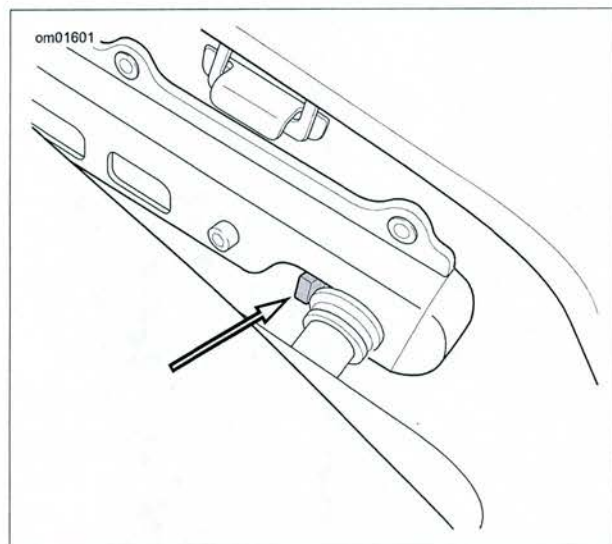

Figure 6. Saddlebag Bracket Latch Engaged