



| | | | | | | |
|------------------------------------|--------------------------|---|---------------------------|---------|------------------------|----------------|
| Retail Operator General Manager | Sales New Motorcycles | Sales Pre-Owned Motorcycles | Business Manager (F&I) | Service | Parts & Accessories | Administration |
| Date: March 2012 | | Source: SI 03/2012 Name: Shawn McLean Title: Service & Technical Manager Phone: 201-307-4131 | | | Revised December 2012 | |
| Bulletin # 32 001 12 (004)R | | | | | | |

**BMW Motorrad
USA**

Service Information Bulletin

Subject: **Supplement:** New Handbrake Lever Fitting (without screen insert) (clamp with M6 threaded fasteners)

Models: R 1200 GS (K25/31), R 1200 GS Adventure (K25/32), R 1200 R (K27/11), K 1300 S (K40/11), K 1300 R (K43/11), F 800 R (K73/02, construction status October 2011 onward).
R 1200 RT (K26/11), K 1600 GT (K48), K 1600 GTL (K48)

Details: BMW Motorrad has radically changed the design of the handbrake lever fitting. The system is now considerably more maintenance-friendly for the reason that it dispenses with screen insert, suppressor weight and separate vent valve.

Overview of changes: The illustration below provides an overview of the design changes to the handbrake lever fitting. The changes themselves are described in more detail in the following pages.

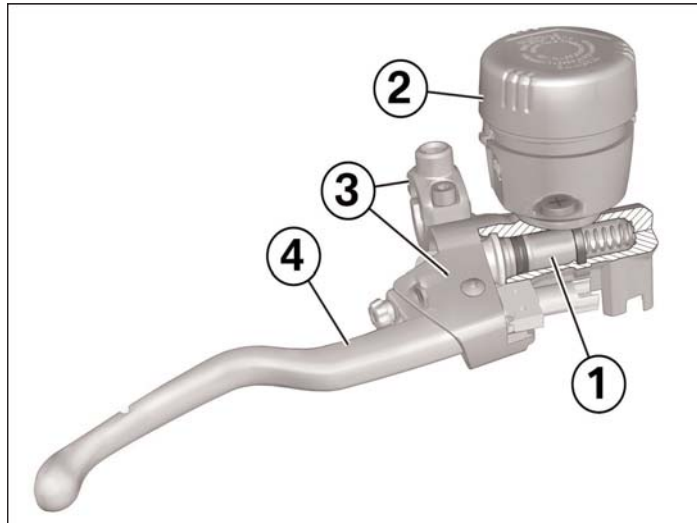

- 1 New piston and sealing technology
- 2 Reservoir with new X bottom valve
- 3 Entire fitting with more rigidity
- 4 Handlebar-fitting lever with improved span adjustment

Production solution: Introduction of the new handlebar fitting (without screen insert). **Incorporation of the new handlebar fitting into series production (clamp with M6 threaded fasteners)**

| Model | Type code | Date of introduction | VIN |
|--|-------------|-----------------------|------------|
| F 800 R (K73/02) Construction status October 2011 onward | 0227 | 10 / 25 / 2011 | ZS50653 |
| K 1300 S (K40/11) | 0509 | 01 / 03 / 2012 | ZV94350 |
| K 1300 R (K43/11) | 0519 | 12 / 16 / 2011 | ZW10055 |
| R 1200 GS (K25/31) | 0460 | 01 / 03 / 2012 | ZX52773 |
| R 1200 GS Adventure (K25/32) | 0480 | 01 / 03 / 2012 | ZX67619 |
| R 1200 R (K27/11) | 0490 | 01 / 03 / 2012 | ZX97110 |
| R 1200 RT (K26/11) | 0440 | 08 / 10 / 2012 | N/A |
| K 1600 GT (K48) | 0611 | 08 / 07 / 2012 | N/A |
| K 1600 GTL (K48) | 0612 | 08 / 07 / 2012 | N/A |

Aftersales solution: Consult the current electronic parts catalogue (ETK/EPC) to ascertain whether the new hand-brake lever fitting can be retrofitted to a particular model and the extent of parts required.

Note: For some construction statuses and equipment configurations, retrofitting is not possible.

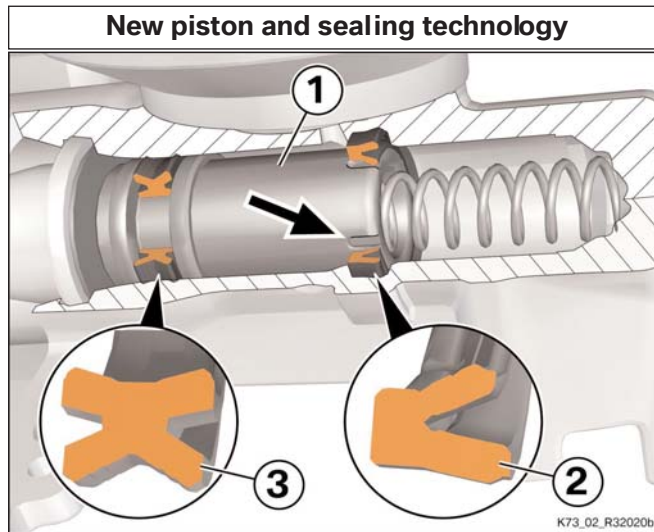

Brake piston (1)

Now features 5 longitudinal grooves (arrow), approx. 2 mm in length, spaced around the circumference (instead of the blow-by bore (without ABS) or central valve (with ABS)).

Improved natural venting (no vent valve necessary for vehicles with ABS).

Fixed primary seal (2) inside the cylinder.

X secondary seal (3) for an optimized sealing function of the fluid-retaining part.

The brake piston will **not** be available as a part on its own and **cannot** be replaced on its own.

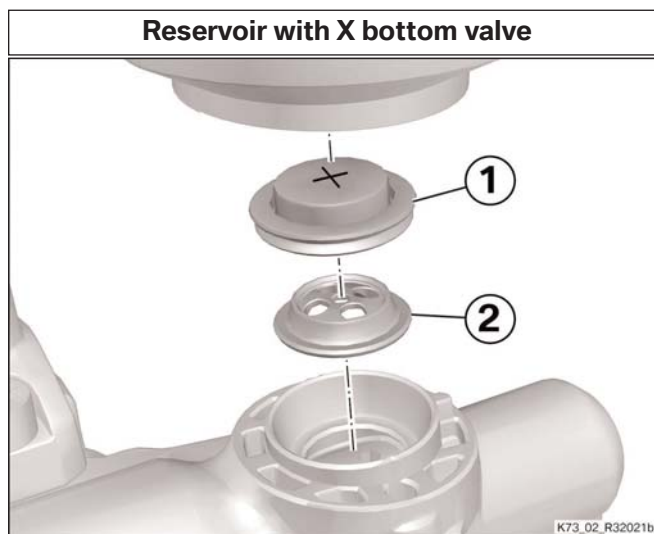

X bottom valve (1)

Helps prevent air penetration into the brake system if the brake fluid foams

Dispenses with decoupler and suppressor weight

Use with screen insert is possible, if necessary

Backup washer (2) to keep the X bottom valve firmly fixed in all operating states.

The reservoir will **not** be available as a part on its own and **cannot** be replaced on its own.

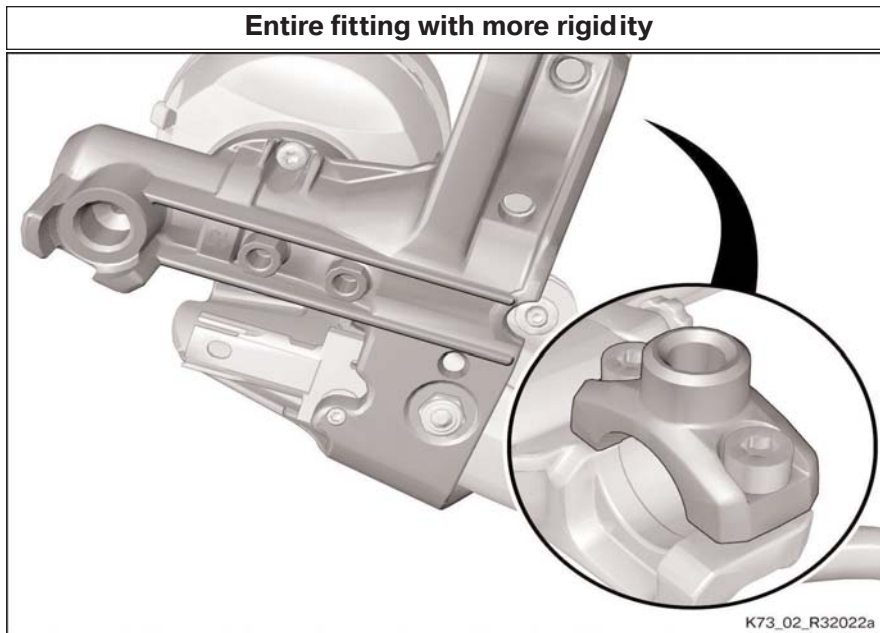

Reinforced body with ribbing.
 New clamp with **M6** threaded fasteners.

The body will **not** be available as a part on its own and **cannot** be replaced on its own.

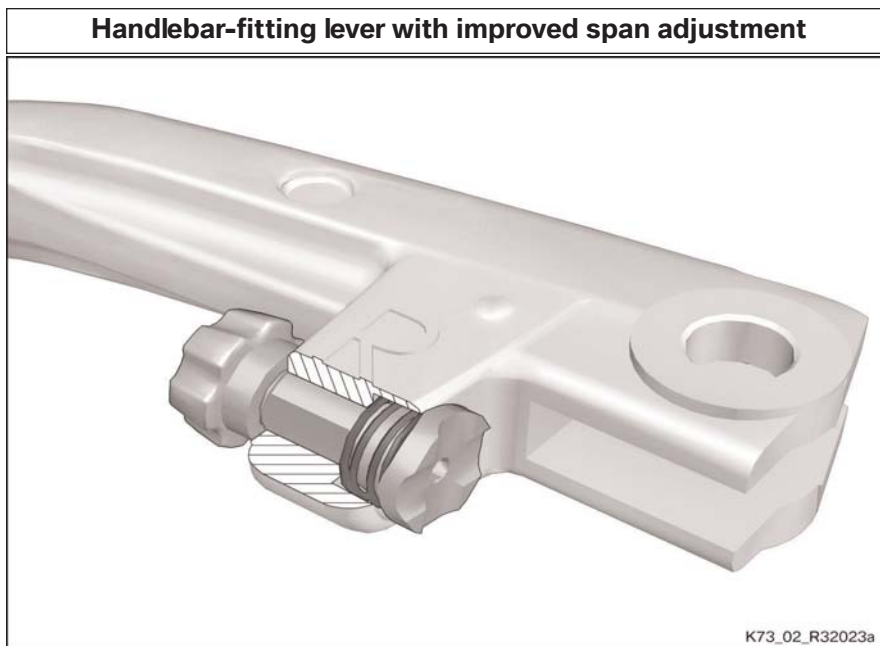

Spring-damped adjuster with larger contact face so that the lever remains set to the span selected by the rider.

The handlebar-fitting lever **can** be replaced on its own for retrofitting.

Warranty Information: For information purposes only

Contact: Service and Technical Manager