



Exhaust Gas Recirculation (EGR) Valve Oil Supply Line

CXU, GU
MP7

FSB 293-016, Exhaust Gas Recirculation (EGR) Valve, Oil Supply Line

(November 2012)

MACK Truck chassis built prior to AUG 14 2012 with MP7 (US10 emissions) engines built prior to engine serial number 547267 were assembled with Exhaust Gas Recirculation (EGR) valve oil supply line (part number 21183591) with the formed tube fitting. The old EGR valve oil supply line with the formed tube fitting is now replaced by the new oil supply line (part number 21544061) with the machined fitting brazed onto the end of the tube to prevent oil leaks at the oil filter housing.

Note: The existing supply line has the retaining plate swedged onto the tube. The new supply line has a brazed fitting and a floating retaining plate.

Note: Do not replace the EGR valve oil supply line unless there is an oil leak in the oil supply line fitting at the oil filter.

Note: This bulletin does not apply to Mack Trucks Australia.

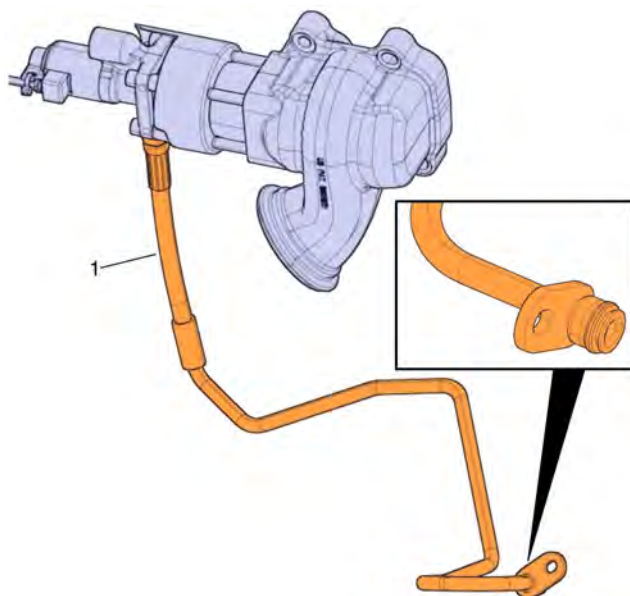

W2077816

EGR Valve Oil Supply Line			
Item #	Part Number	Description	QTY
1	21544061	Pressure Hose, EGR Valve Oil Supply	1

Procedure

You must read and understand the precautions and guidelines in Service Information, group 20, "General Safety Practices, Engine" before performing this procedure. If you are not properly trained and certified in this procedure, ask your supervisor for training before you perform it.

- 1 Secure the vehicle for service by parking it on a flat level surface, applying the parking brake, chocking the rear wheels, and placing the transmission in neutral or park.
- 2 Unlatch and open hood.
- 3 Disconnect all cables from the negative (ground) battery terminals to prevent personal injury from electrical shock and prevent damage to electrical components.
- 4 Using coolant injector/extractor (85112740), drain the engine coolant if applicable.
- 5 Remove inner fender from cab (right front).
- 6

Note: Steps 6 through 10 apply to the removal of the non-integrated Aftertreatment Hydrocarbon Doser (AHD). Skip to step 11 for removal of the integrated AHD.

Remove coolant lines (Item 2) from the AHD.

- 7 Remove fuel line (Item 3) from AHD.
- 8 Remove air line (Item 4) from AHD.
- 9 Remove P-clamps (Item 5) from diffuser pipe.
- 10 Remove AHD (Item 1) from diffuser pipe.

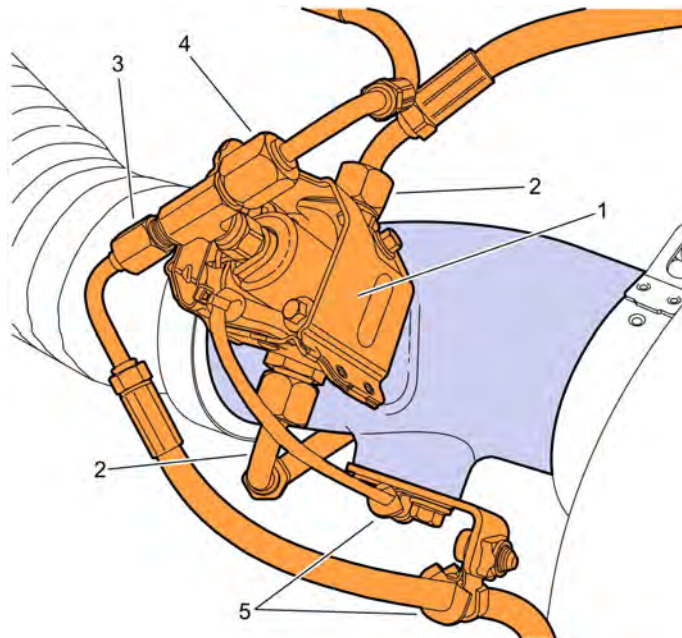

W2077817

11

Note: Steps 11 through 12 apply to the integrated AHD.

Remove line from the AHD.

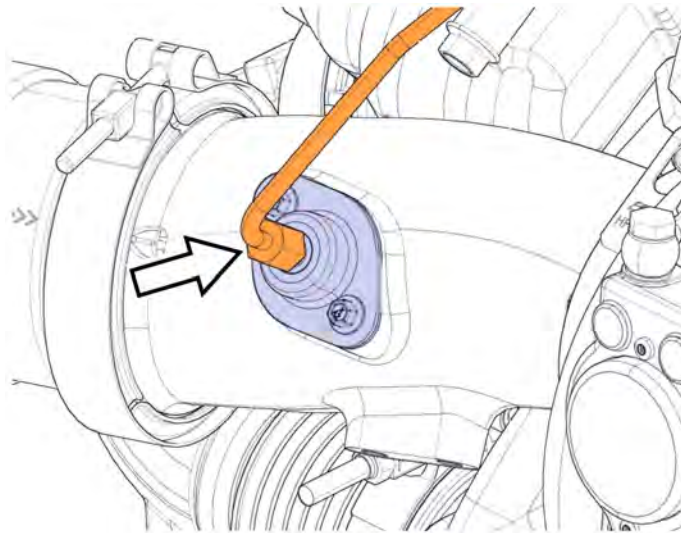

W2077818

12 Remove the AHD and gaskets from diffuser pipe.

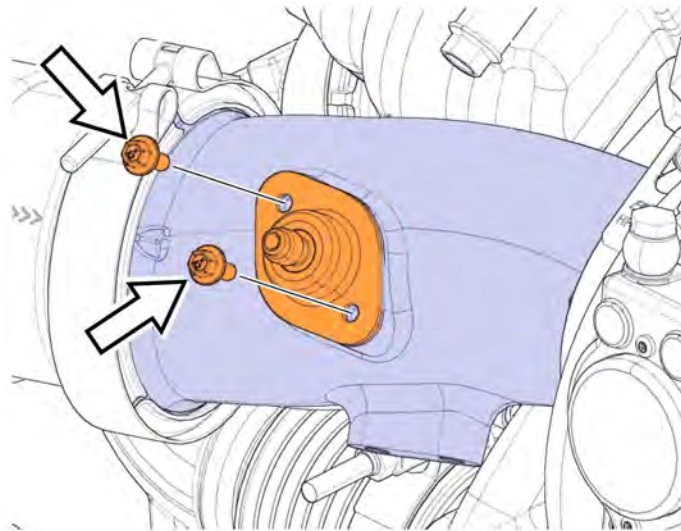

W2077819

13 Remove clamps securing the diffuser pipe and exhaust pipe.

14 Remove diffuser pipe and exhaust pipe as shown in figure below.

Note: Inspect v-band clamps for damage. If no damage is present, store clamps for reuse. Replace clamps if damage is present.

Note: Discard gaskets and replace with new ones.

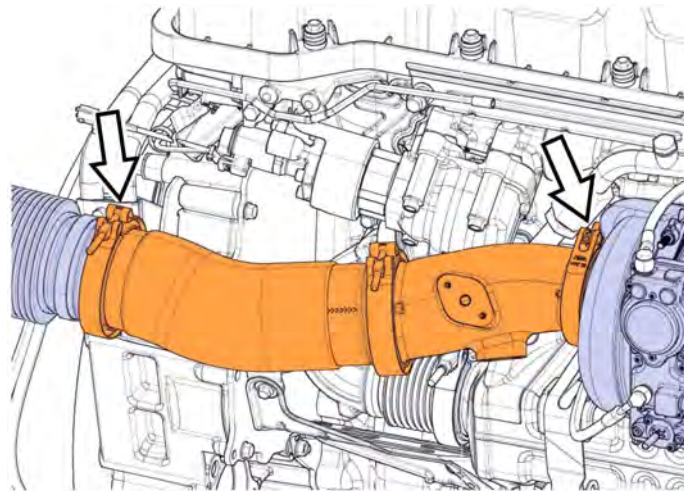

W2077820

15 Remove clamps securing the Exhaust Gas Recirculation (EGR) outlet pipe.

16 Remove EGR outlet pipe.

Note: Inspect v-band clamps for damage. If no damage is present, store clamps for reuse. Replace clamps if damage is present.

Note: Discard gaskets and replace with new ones.

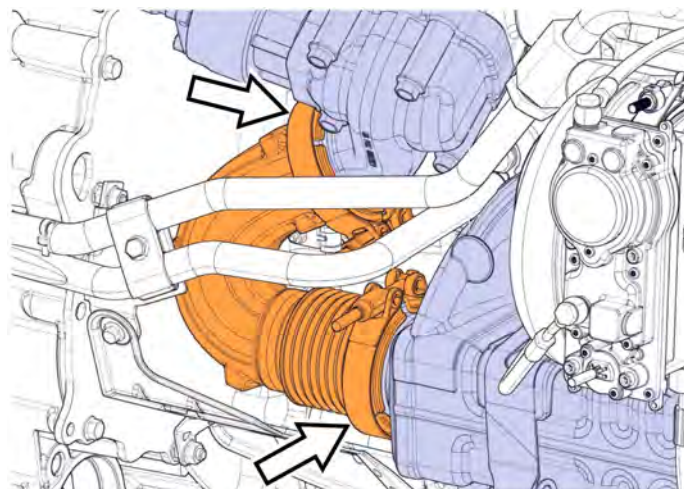

W2077821

17 Remove P-clamps from oil supply line.

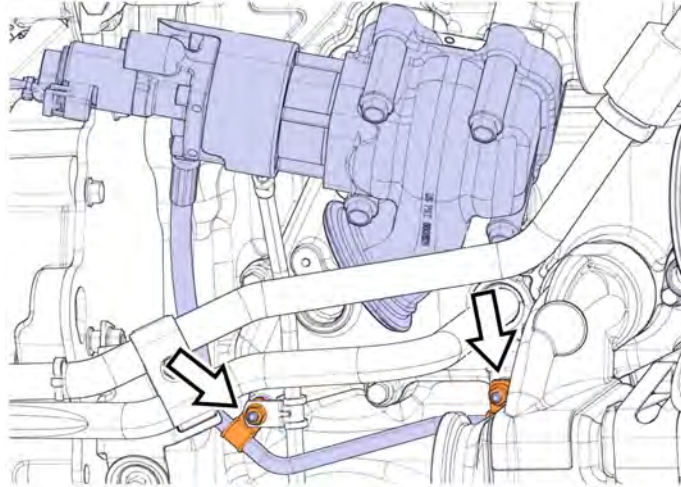

W2077822

18 Disconnect oil supply line from EGR valve.

19 Disconnect the oil supply line at the oil filter housing and remove oil supply line.

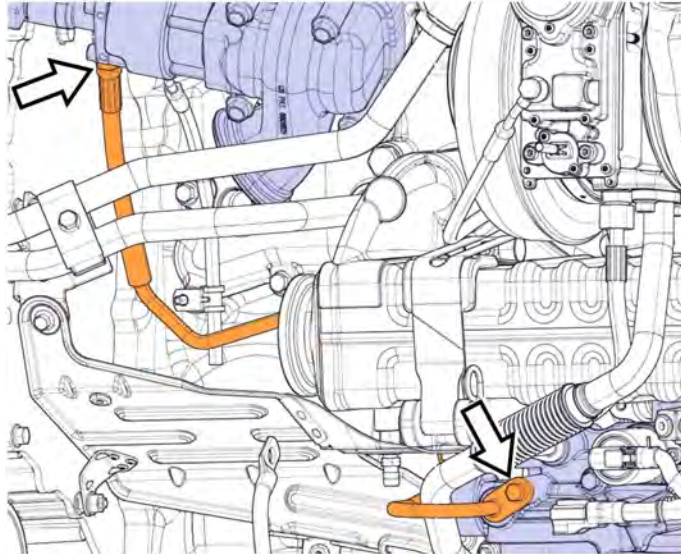

W2077823

20 Install the replacement oil supply line.

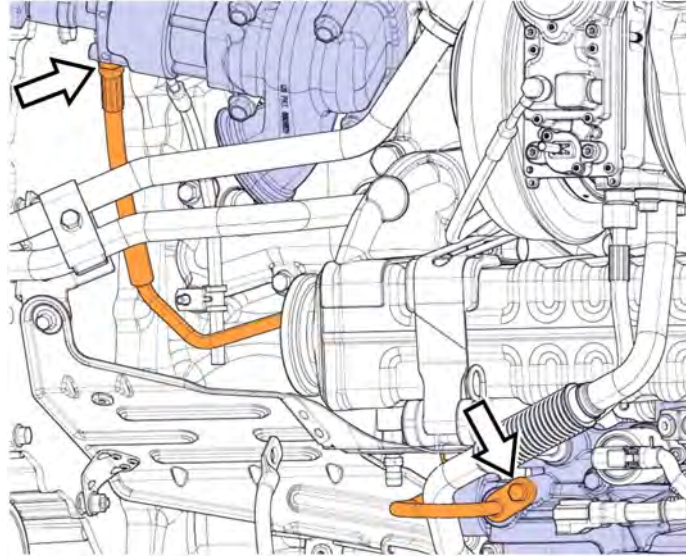

W2077823

21 Loosely install P-clamps on oil line and connect oil supply line fitting at EGR valve.



W2077822

22 Tighten fitting nut at EGR valve to 30 ± 5 Nm (22 ± 4 ft-lb).

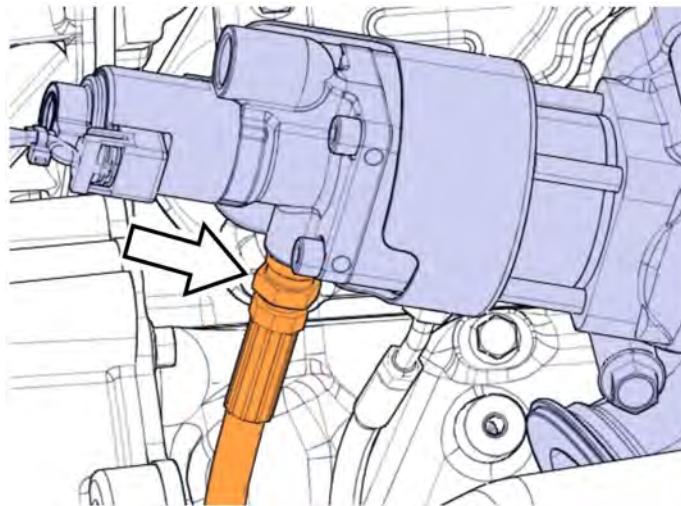

W2077824

23 Tighten mounting bolt at oil filter housing to 24 ± 5 Nm (18 ± 4 ft-lb).

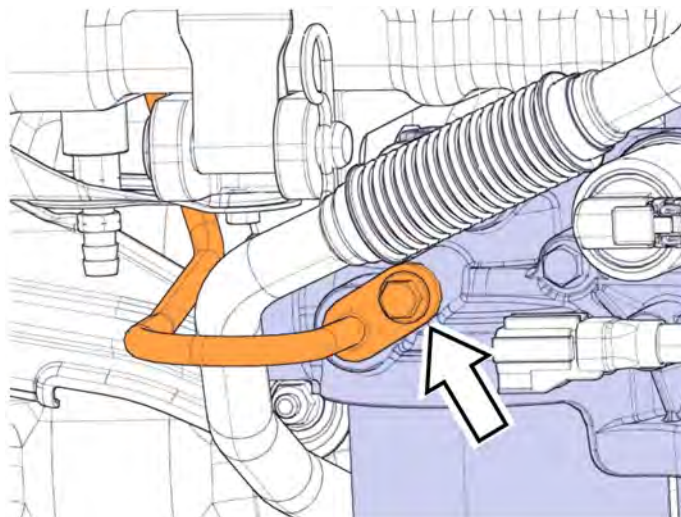

W2077825

24 Tighten P-clamp fasteners securing oil supply line to 24 ± 4 Nm (18 ± 3 ft-lb).

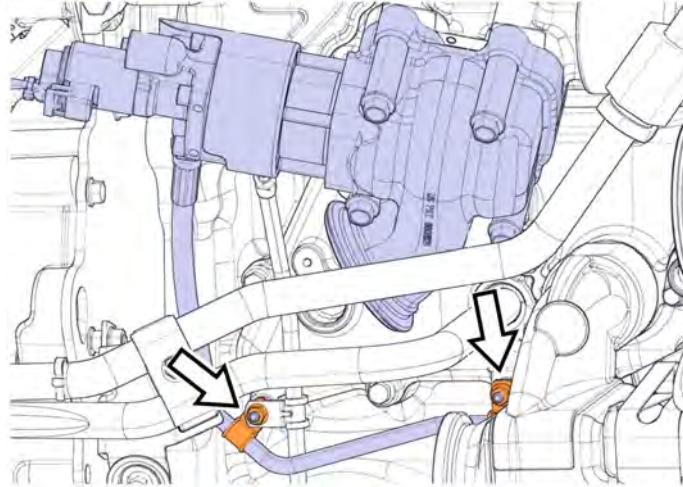

W2077822

25 Install EGR cooler outlet pipe with v-band clamps and new gaskets.

26 Tighten v-band clamps to 6 Nm (53 in-lb).

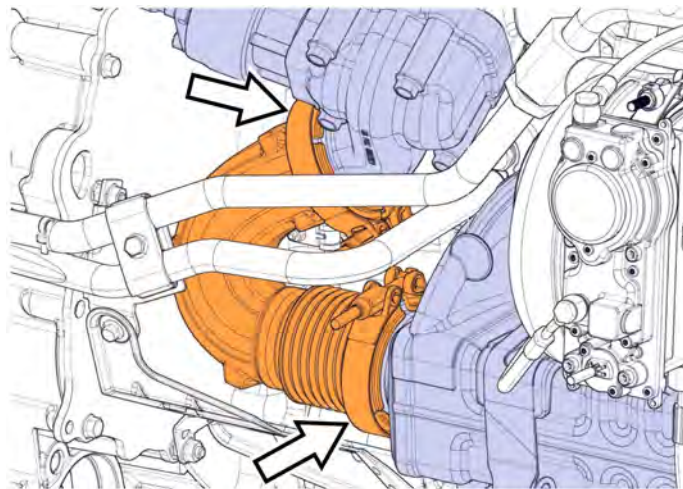

W2077821

- 27 Install diffuser pipe and exhaust pipe using v-band clamps and new gaskets.
- 28 Tighten v-band clamps to 12 ± 2 Nm (106 ± 18 in-lb).

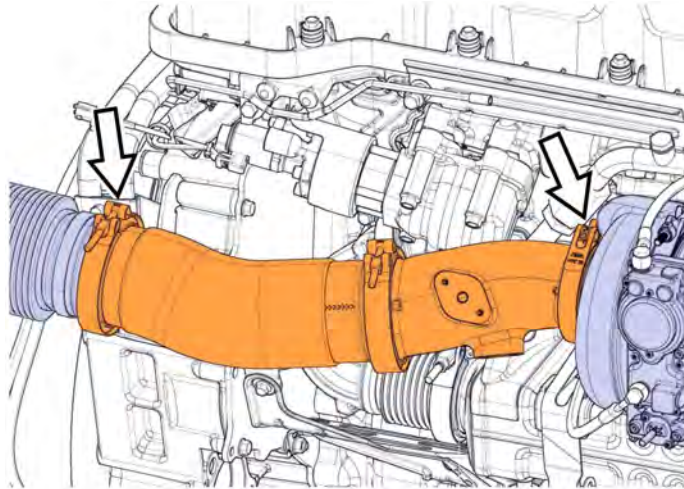

W2077820

- 29 Clean diffuser pipe and AHD mating surfaces.
- 30

Note: Steps 30 through 32 apply to installation of the integrated AHD. Skip to step 33 for installation of the non-integrated AHD.

Install AHD and new gaskets.

- 31 Tighten fasteners securing AHD to 14 ± 0.5 Nm (124 ± 4 in-lb).

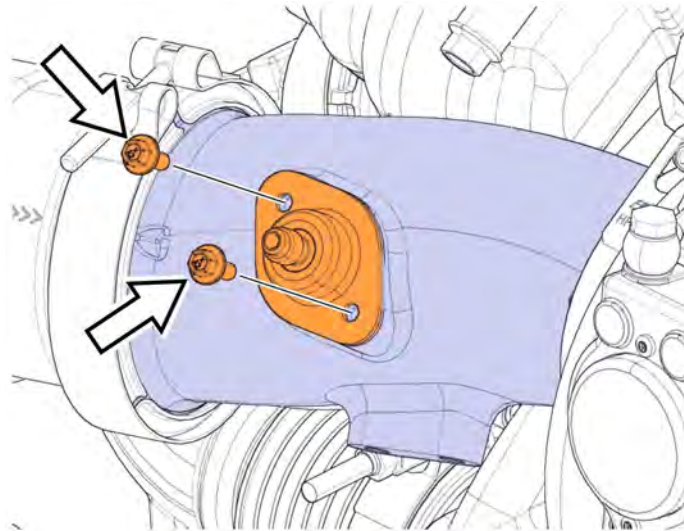

W2077819

32 Install line to AHD and tighten fitting to 15 ± 0.5 Nm (133 ± 4 in-lb).

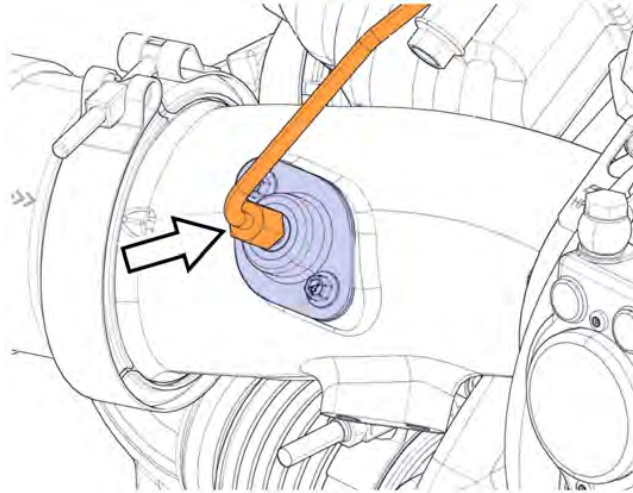

W2077818

33

Note: Steps 33 through 39 apply to the installation of the non-integrated Aftertreatment Hydrocarbon Doser (AHD).

Install AHD and new gasket on diffuser pipe.

34 Tighten fasteners securing AHD to 14 ± 0.5 Nm (124 ± 4 in-lb).

35 Install air line (Item 4) and tighten fitting to 27 Nm (20 ft-lb).

36 Install fuel line (Item 3) and tighten fitting to 15 ± 0.5 Nm (133 ± 4 in-lb).

37 Install coolant lines (Item 2) and tighten fittings to 48 ± 5 Nm (35 ± 4 ft-lb).

38 Install P-clamps (Item 5) and tighten fasteners to 24 ± 4 Nm (18 ± 3 ft-lb).

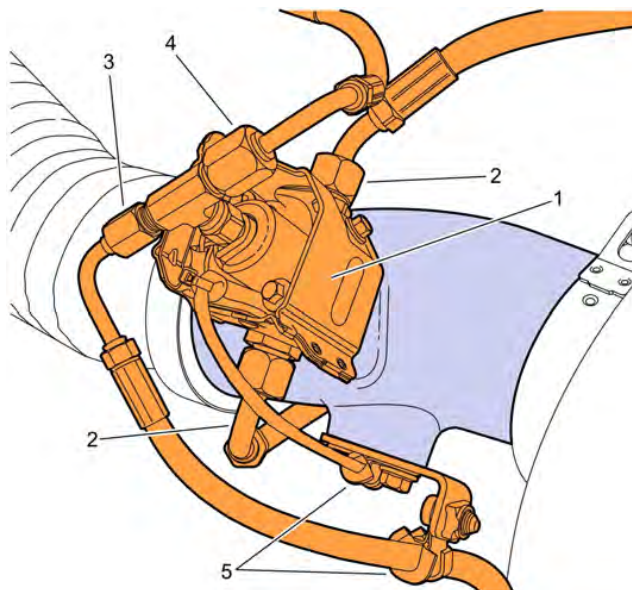

W2077817

- 39 Install inner fender (right side).
- 40 Using coolant injector/extractor (85112740), fill cooling system.
- 41 Reconnect all previously removed cables to the negative (ground) battery terminals.
- 42 Start engine, check for leaks and proper operation. Clear any diagnostic trouble codes (DTC's).
- 43 Close and latch hood.

Reimbursement

This repair may be eligible for reimbursement if a product failure was experienced within time and mileage limits of the applicable Warranty coverage. Reimbursement is obtained via the normal claim handling process.	
Claim Type (used only when uploading from the Dealer Bus. Sys.)	01
Labor Code	
Primary Labor Code	2141U-36-80 1.6 hrs.
Causal Part	21183591

MACK Trucks North America engages in a comprehensive program of testing and evaluating to provide the best possible product. MACK Trucks North America however, is not committed to, or liable for updating existing vehicles.