



# RECALL CAMPAIGN BULLETIN

Reference:

NTB12-092

Date:

October 11, 2012

## VOLUNTARY EMISSIONS RECALL CAMPAIGN 2009 ALTIMA SEDAN AND COUPE ECM REPROGRAM AND MANIFOLD CATALYST

**CAMPAIGN ID #:** PC130**APPLIED VEHICLE:** 2009 Altima Sedan and Coupe (C/L32)  
with SULEV (California Specification) 2.5 engine

**Check Service COMM to confirm campaign eligibility.**

### INTRODUCTION

Nissan has determined that some 2009 Model Year Altima vehicles are equipped with an improperly calibrated Engine Control Module (ECM) that may incorrectly detect engine valve closure as engine knock. To correct this condition, Nissan is conducting this Voluntary Emissions Recall Campaign to reprogram the Engine Control Module, and inspect (and if needed replace) the exhaust manifold and front exhaust tube. This service will be performed at no charge for parts or labor.

### IDENTIFICATION NUMBER

Nissan has assigned identification number PC130 to this campaign. This number must appear on all communications and documentation of any nature dealing with this campaign.

### DEALER RESPONSIBILITY

It is the dealer's responsibility to check Service Comm for the campaign status on each vehicle falling within the range of this voluntary emissions recall which for any reason enters the service department. This includes vehicles purchased from private parties or presented by transient (tourist) owners and vehicles in a dealer's inventory.

Nissan Bulletins are intended for use by qualified technicians, not 'do-it-yourselfers'. Qualified technicians are properly trained individuals who have the equipment, tools, safety instruction, and know-how to do a job properly and safely. NOTE: If you believe that a described condition may apply to a particular vehicle, DO NOT assume that it does. See your Nissan dealer to determine if this applies to your vehicle.

## IMPORTANT

**Attention California Dealers:** California law prohibits owners from renewing their California registration if emissions related recall work has not been performed. California dealers are now required to issue a proof of correction certificate to vehicle owners upon completion of emission related recall work. Please fill out one of the campaign completion forms for each owner that has this campaign performed. Instruct owners to keep this certificate unless they are requested to mail it to the DMV. A sample of the form is shown below.

**NOTE:** These forms are available from Nissan Publications (1-800-247-5321) at no charge (item number **CAEMRC-2/09**).

					<b>Vehicle Emission Recall Proof of Correction</b>									
License Number	Make	Year Model	Body Type	Vehicle Identification Number										
				<input type="text"/>										
Manufacturer: Nissan North America in U.S.A.					Recall Number _____									
The above described vehicle has been repaired, modified and/or equipped with new emission control devices to meet applicable California Emission Control Laws.														
Dealer's Name					Address, City, State and Zip									
Date					Dealership's Authorized Signature									
					X									
<b>Return this certificate to DMV only when required - otherwise retain for your records. This certificate is only required for vehicles registered in California.</b>														

CAEMRC-2/09

## Table of Contents

	Page
Repair Overview .....	4
SERVICE PROCEDURE .....	5
Exhaust Manifold and Front Tube Leak Check .....	5
Exhaust Manifold Stay Removal .....	10
Front Exhaust Tube Replacement .....	11
Exhaust Manifold Replacement .....	13
ECM Reprogram .....	20
PARTS INFORMATION.....	28
CLAIMS INFORMATION.....	29
OWNER'S LETTER.....	30

## REQUIRED SPECIAL TOOL

### Leak Tester – J-50976

- Additional tools can be ordered from TECH-MATE at 1-800-662-2001.

#### NOTE:

- When using this tool, do not block the regulator bleed hole with a finger or any other item.
- Blocking the regulator bleed hole may damage the tool.

### High Temperature Gasket for Leak Tester J-50976-3



Figure A

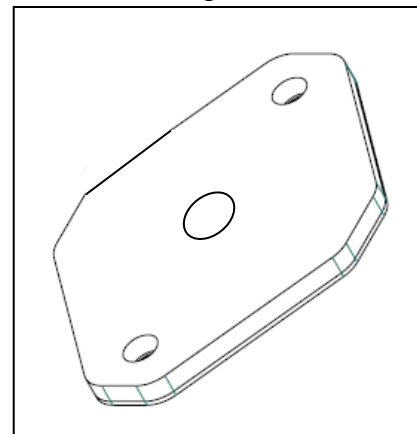
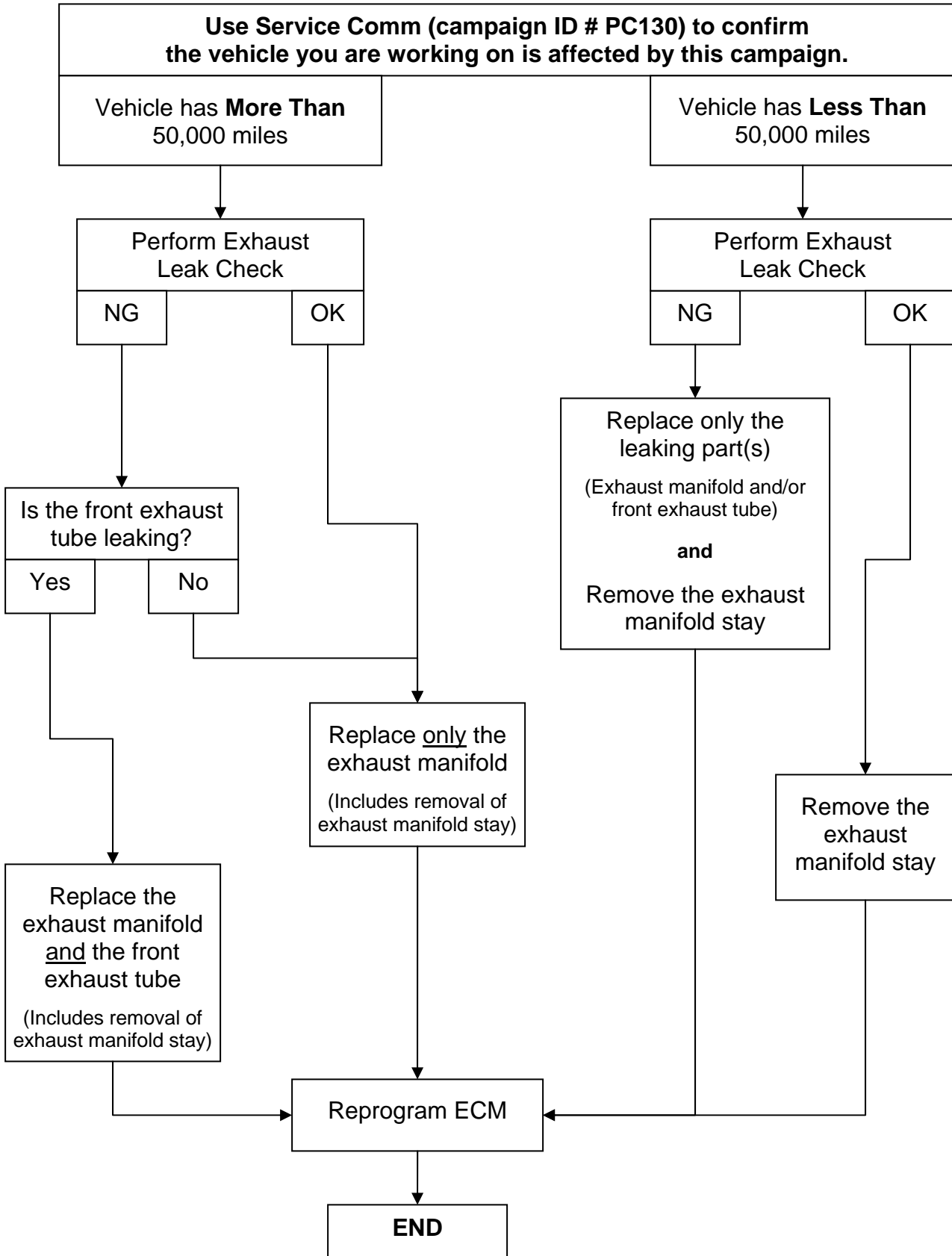

Figure B

# REPAIR OVERVIEW



## SERVICE PROCEDURE

**IMPORTANT:** After leak check and any needed part replacements, make sure to perform ECM reprogram – page 20.

### Exhaust Manifold and Front Tube Leak Check

1. Position the vehicle on a hoist ready to be lifted.
2. Turn the ignition **OFF**.
3. Raise the vehicle on the hoist.

4. **WARNING:** Wait for the exhaust system to cool before touching exhaust system components. Hot exhaust components can cause severe burns.



Figure P1

5. Remove the cross brace shown in Figure P2.

- Cross brace is held on with 4 bolts, 2 on each side.

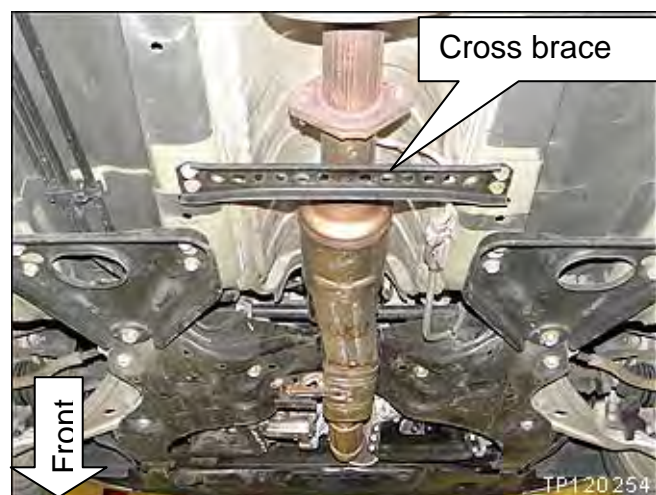

Figure P2

6. Unbolt the front exhaust tube hanger.

- Hanger is held on with 2 bolts.

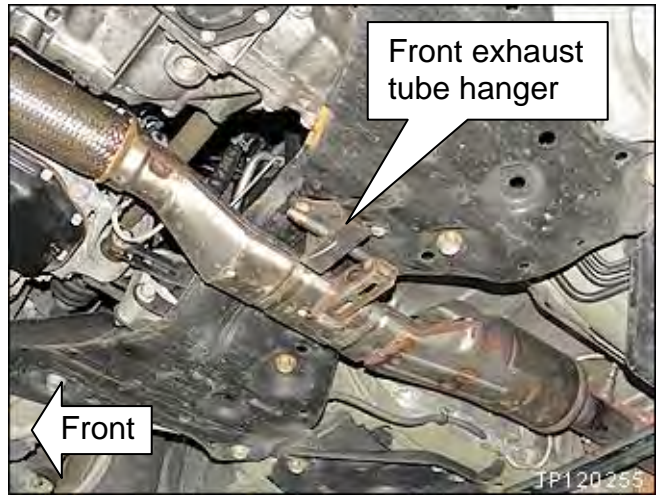

Figure P3

7. Unbolt the front exhaust tube from the center exhaust tube at the flange.

- Flange is held together with 2 studs and 2 nuts.

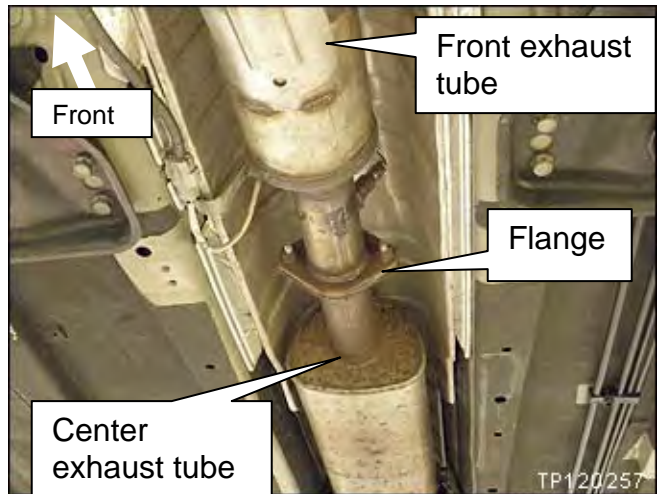

Figure P4

8. Attach an elastic strap (or other suitable support) under the rear of the front exhaust tube (see Figure P5).

**NOTE:** The elastic strap should support the front exhaust tube when it is disconnected from the center exhaust tube.

**CAUTION:** Make sure exhaust tube has cooled enough not to burn the elastic strap or other support.

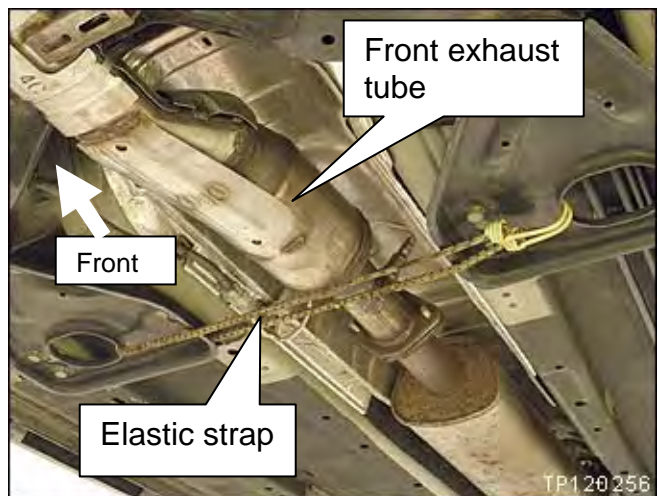

Figure P5

9. Disconnect the front exhaust tube from the center exhaust tube.

**NOTE:** Make sure the rear oxygen sensor harness is not stretched.

10. Let the elastic strap (or other suitable support) support the front exhaust tube.

**CAUTION:** Make sure exhaust tube has cooled enough not to burn the elastic strap or other support.

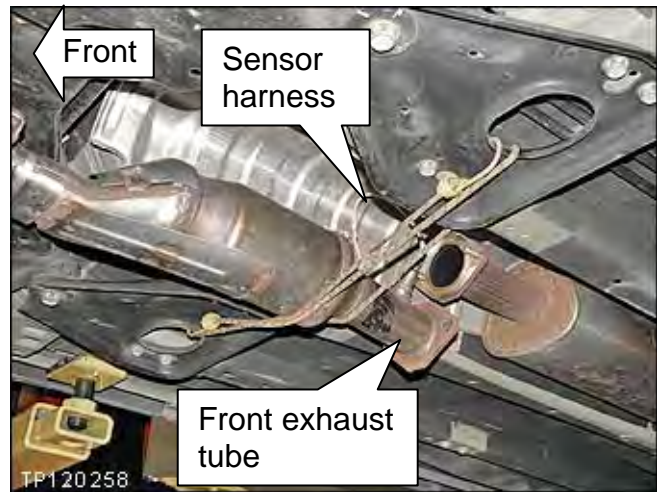

Figure P6

11. Attach special tool J-50976 to the rear of the front exhaust tube as shown in Figure P7.

**CAUTION:** Make sure High Temperature Gasket (J-50976-3) has been installed on the special tool before bolting to the tube.

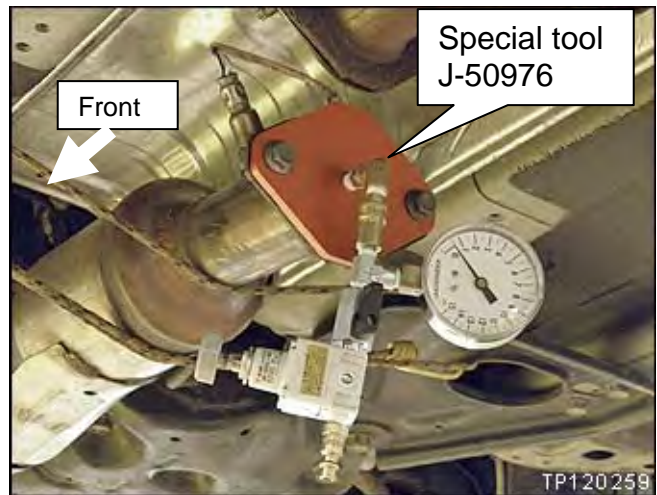

Figure P7

12. Connect a shop air hose to special tool J-50976.

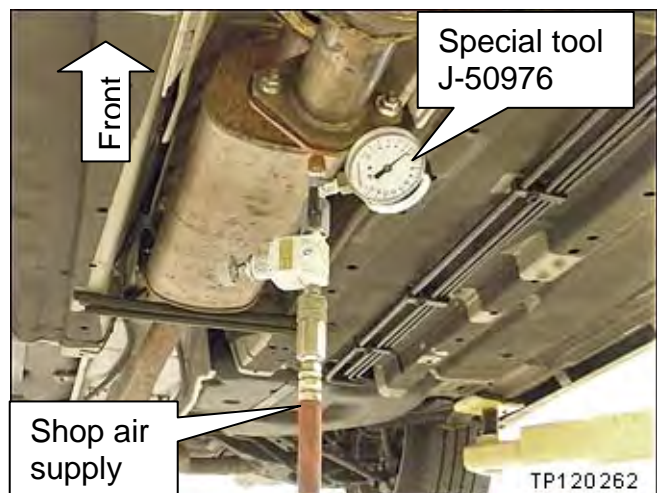

Figure P8

13. Set the valve on special tool J-50976 to the open position (see Figure P9b).
14. Attach a 19 mm socket with handle to the front crank pulley (see Figure P9a).
15. Position the engine crank shaft at the point of the highest pressure on the gauge as follows:

**WARNING:** Make sure the **ignition is OFF** or the engine may turn on its own.

- a. Watch the pressure gauge while slowly turning the engine (see Figures P9a and P9b).
  - Turn the engine clockwise (as you face the front of the engine).
- b. When the pressure gauge is reading at the highest point (most PSI) stop turning the engine.
  - Highest pressure will be between 5 and 6 PSI.



Figure P9a

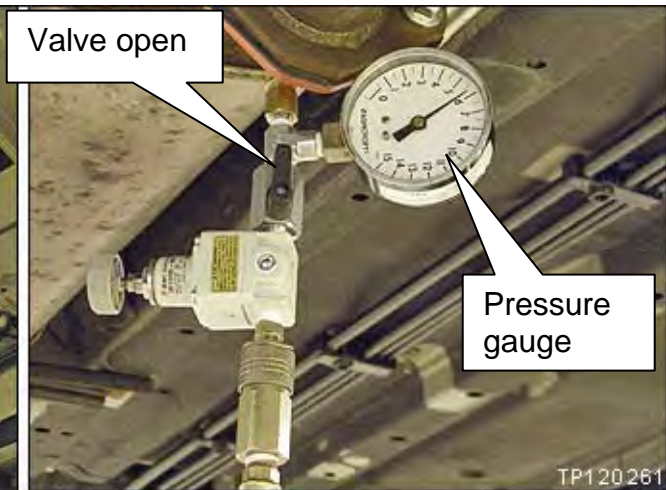

Figure P9b

16. Check for leaks as follows:

- a. Turn the valve to the closed position.
- b. The pressure will start to drop.
- c. When pressure drops to 5 PSI, begin a 20 second count.
- d. At the end of the 20 second count, read the pressure.

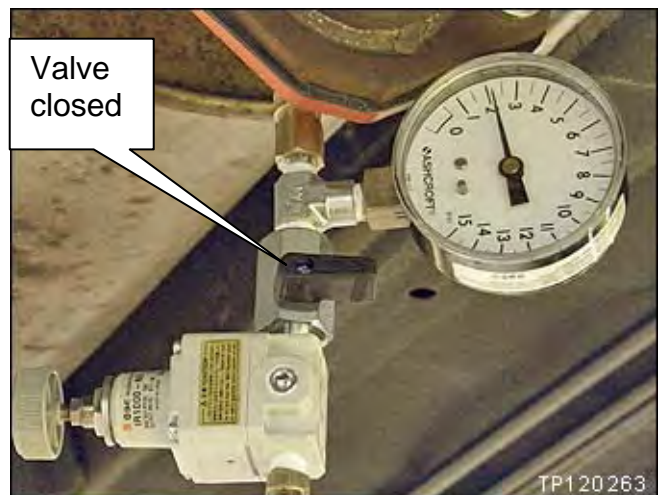

Figure P10

Go to OK/NG information on the next page.



**OK: Pressure is 2 psi or above;** there is no leak in the front tube or manifold.

- If vehicle has **more than** 50,000 miles, go to Exhaust Manifold Replacement on page 13.
- If vehicle has **less than** 50,000 miles:
  - Remove the exhaust manifold stay – see page 10.
  - Reinstall the front exhaust tube.

Use a new gasket between the front tube and the center tube.

Nuts for the front exhaust tube to center tube; torque to 14 N•m (1.4 kg-m, **10 ft-lb**).

Bolts for front exhaust tube hanger; torque to 14 N•m (1.4 kg-m, **10 ft-lb**).

Bolts for cross brace; torque to 21-29 N•m (2.1-2.9 kg-m, **15-21 ft-lb**).

**NG: Pressure is below 2 psi;** there is a leak in the front tube, manifold, or gasket.

A. By feel and sound, locate the leak.

**NOTE:**

- If needed, eliminate any air hiss noise from the air supply hose or the tool regulator by disconnecting the air hose from special tool J-50976.
- If needed, use soap and water to confirm leak location.

B. Replace **only** the leaking part (gasket, front exhaust tube, and/or exhaust manifold).

**NOTE:**

- For all vehicles with **more than 50,000 miles**, **replace the exhaust manifold** even if it does not have a leak.
- Replacement of the exhaust manifold includes removal of the exhaust manifold stay.
  - For a leak at the gasket between the exhaust manifold and front tube; refer to page 11 (**Front Exhaust Tube Replacement**) and replace only the gasket.
  - For a leak at the gasket between the exhaust manifold and engine head; refer to page 13 (**Exhaust Manifold Replacement**) and replace only the gasket.
  - For a leak in the front tube; refer to page 11 (**Front Exhaust Tube Replacement**).
  - For a leak in the exhaust manifold; refer to page 13 (**Exhaust Manifold Replacement**).

## Exhaust Manifold Stay Removal

**NOTE:** Remove the exhaust manifold stay from all vehicles affected by this campaign.

1. Remove the exhaust manifold stay and the related attachment parts (see Figures S1 and S2).
  - These parts will not be reused; do not reinstall.

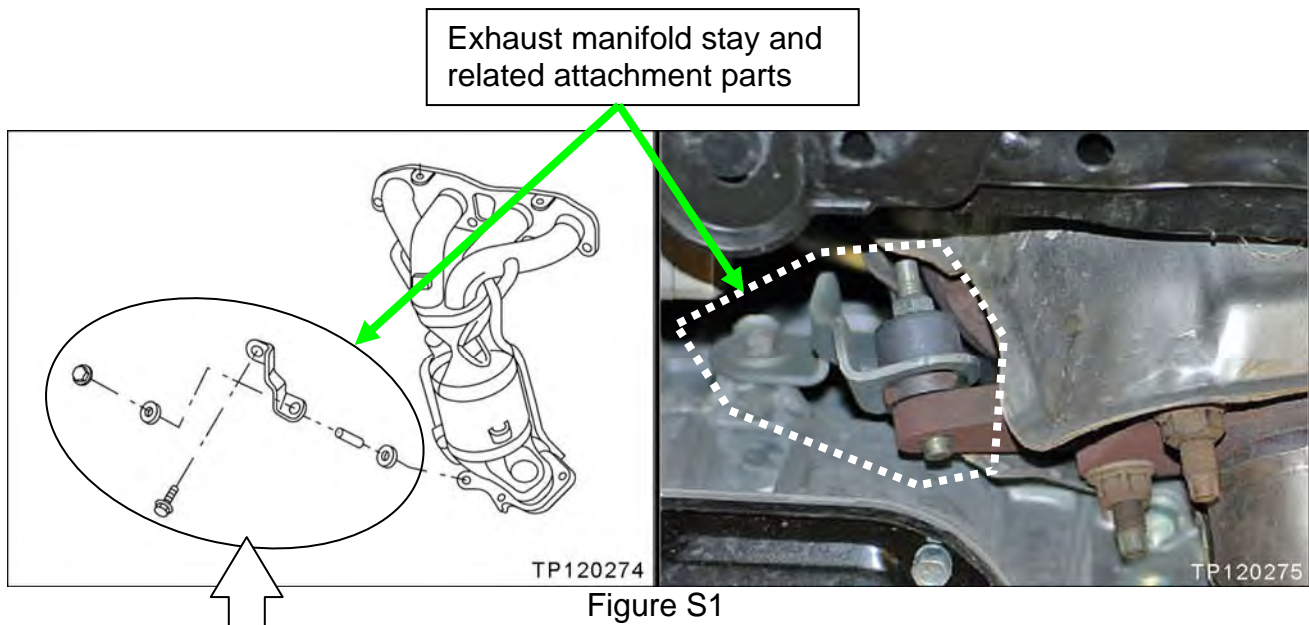

Figure S1

Remove these parts.

Do not reinstall.

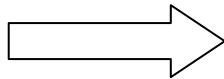

Figure S2

## Front Exhaust Tube Replacement

**NOTE:** Replace the front exhaust tube only if a leak is found in the tube during the leak check on page 8.

1. Raise the vehicle on the hoist.

2. **WARNING:** Wait for the exhaust system to cool before touching exhaust system components. Hot exhaust components can cause severe burns.



Figure T1

3. Remove the cross brace shown in Figure T2.

- Cross brace is held on with 4 bolts, 2 on each side.

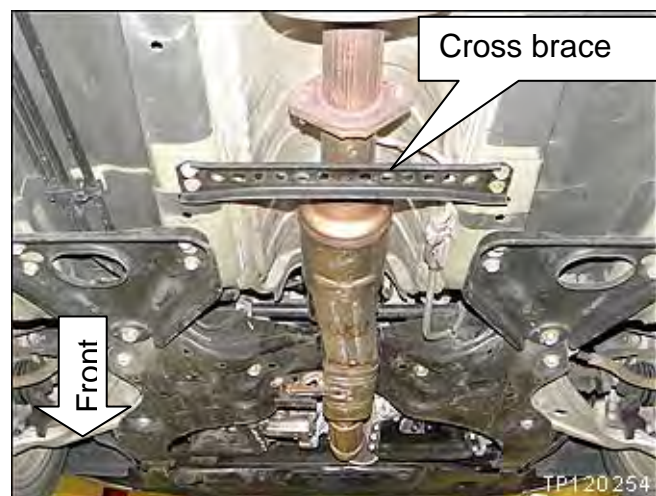

Figure T2

4. Remove the front exhaust tube as follows (refer to Figure T3):

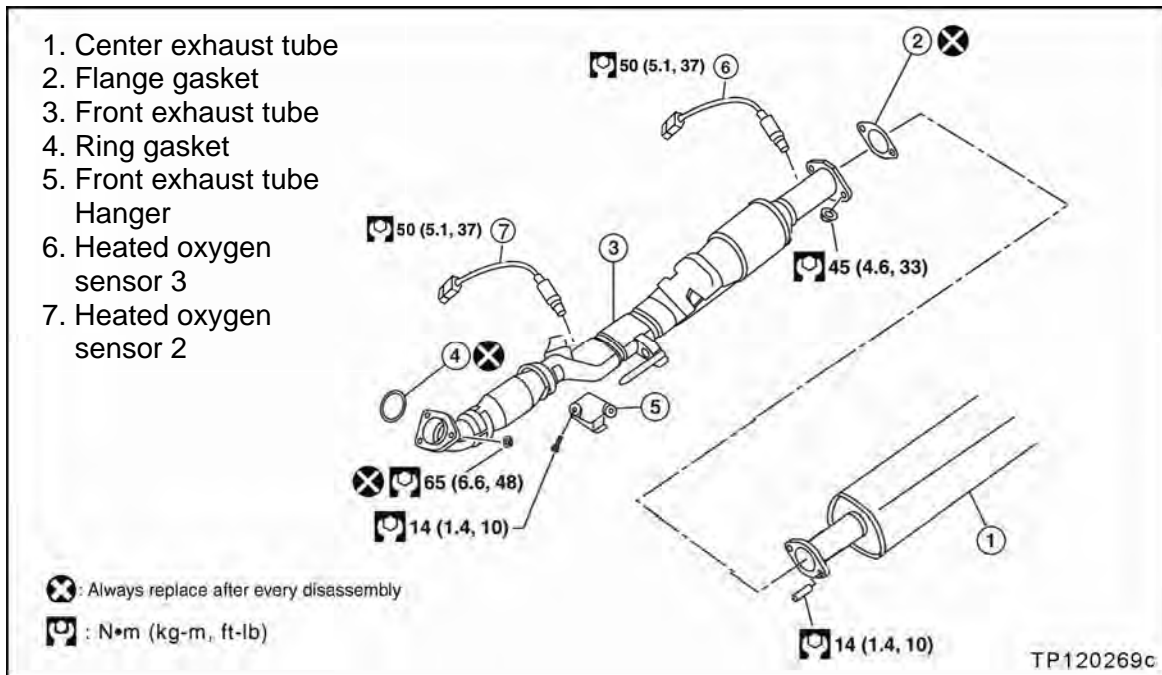

Figure T3

- a. Disconnect both heated oxygen sensors.
  - b. Unbolt the front exhaust tube hanger.
    - Hanger is held on with 2 bolts.
  - c. Unbolt the front exhaust tube from the center exhaust tube.
    - Tube flange is held together with 2 studs and 2 nuts.
  - d. Unbolt the front exhaust tube from the exhaust manifold.
    - Tube to manifold held together with 3 studs and 3 nuts.
  - e. Remove the front tube from the vehicle.
5. Swap the heated oxygen sensors (2 and 3) from the old tube to the new tube.
- If the sensors are seized in the exhaust tube, refer to NTB10-009 for sensor removal.
  - Refer to Figure T3 for torque specifications.
6. Install front exhaust tube in reverse order.
- Use a new ring gasket.
  - Use a new flange gasket.
  - Use new nuts for tube to manifold connection.
  - Refer to Figure T3 for torque specifications.
  - Bolts for cross brace; torque to 21-29 N•m (2.1-2.9 kg-m, **15-21 ft-lb**).

## Exhaust Manifold Replacement

### NOTE:

- For all vehicles with **more than** 50,000 miles, replace the exhaust manifold. (Replacement of the exhaust manifold includes removal of the exhaust manifold stay.)
- For vehicles with **less than** 50,000 miles; only replace the exhaust manifold if a leak in the exhaust manifold is found during the leak check on page 8.

1. Write down the radio station presets.

Presets	1	2	3	4	5	6
A						
B						
C						
SAT						
Fade:	Balance:		Bass:		Treble:	

2. If equipped, write down the customer settings for the ATC (Automatic Temperature Control) system. (Refer to the Service Manual as needed).

3. Disconnect the negative battery cable.

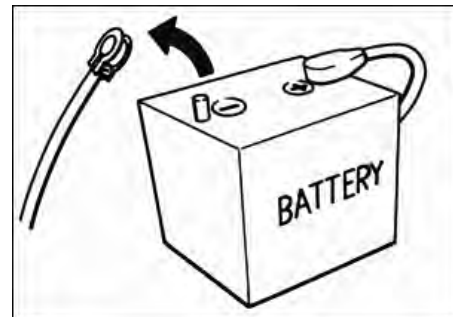

Figure M1

4. Raise the vehicle on a hoist.



Figure M2

5. **WARNING:** Wait for the exhaust system to cool before touching exhaust system components. Hot exhaust components can cause severe burns.

6. Remove the front exhaust tube.

- Refer to Front Exhaust Tube Replacement on page 11.

7. Remove the engine under cover.

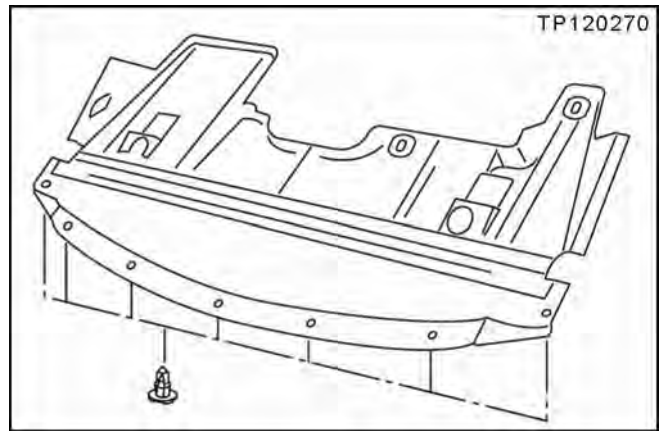

M3

8. Remove the right (passenger side) front wheel.

9. Remove the fender protector side cover from the right side (passenger side) wheel housing.

- Side cover is held on with 5 clips.

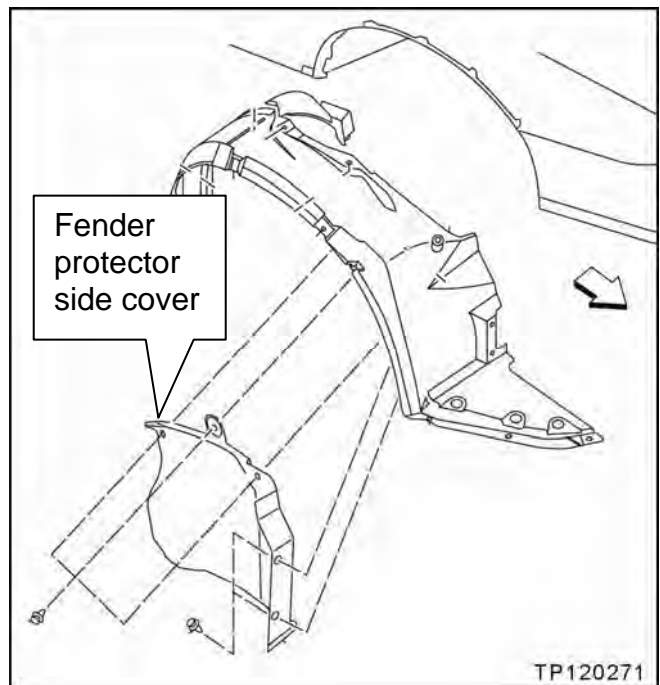

Figure M4

10. Remove the drive belt as follows:

**CAUTION:**

- Do not loosen (do not turn counterclockwise) the auto-tensioner pulley bolt. If turned counterclockwise, the complete auto-tensioner must be replaced as a unit, including the pulley (which is not covered in this campaign).
- Avoid placing a hand in a location where pinching may occur if the wrench accidentally comes off.

- a. Use a 14 mm off-set box wrench on the auto-tensioner pulley bolt.
- b. Pull / push on the wrench as if turning the bolt in a clockwise direction.



Figure M5

- c. While holding / pulling the wrench, insert a rod (approximately 6 mm / 0.24 inch diameter and at least 25 mm / 1 inch long) through the tensioner retaining boss.

**NOTE:** For illustration, a 6 mm Allen driver was used to hold the tensioner / retaining boss.

- d. Carefully allow the tensioner to move to a relaxed position (carefully release your pulling force on the wrench).

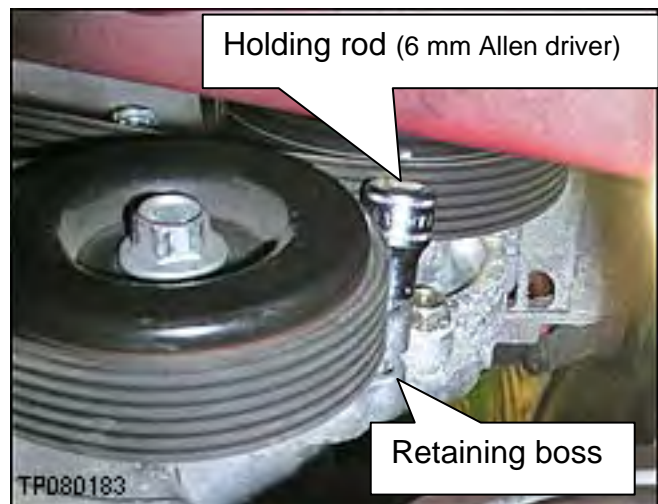

Figure M6

- e. Remove the drive belt.

11. Remove the alternator as follows (refer to Figure M7):

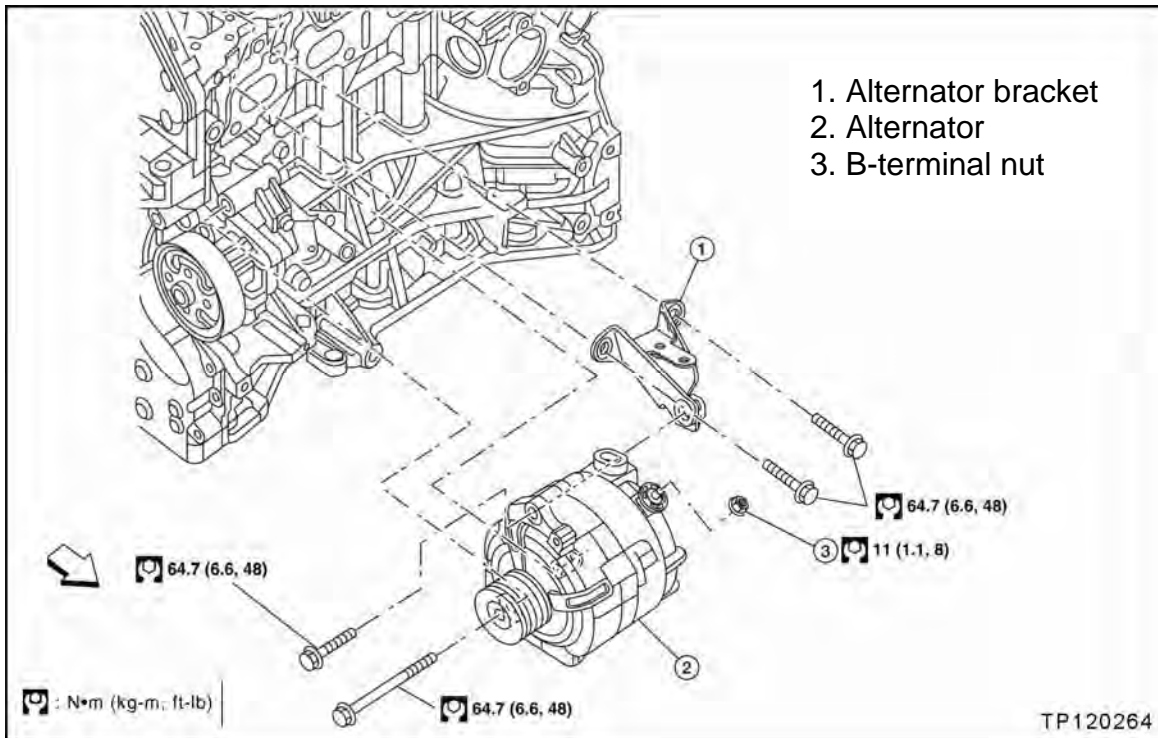

Figure M7

- a. Disconnect B-terminal nut and remove B-terminal wire.
- b. Remove alternator harness ground bolt.
- c. Disconnect electrical harness from the alternator.
- d. Remove 2 bolts holding the alternator to alternator bracket and engine.
- e. Remove the alternator from the vehicle upward (from the top of the engine).
- f. Remove 2 bolts holding the alternator bracket to the engine.
- g. Remove the alternator bracket from the vehicle.



12. Remove the exhaust manifold as follows (refer to Figure M8).

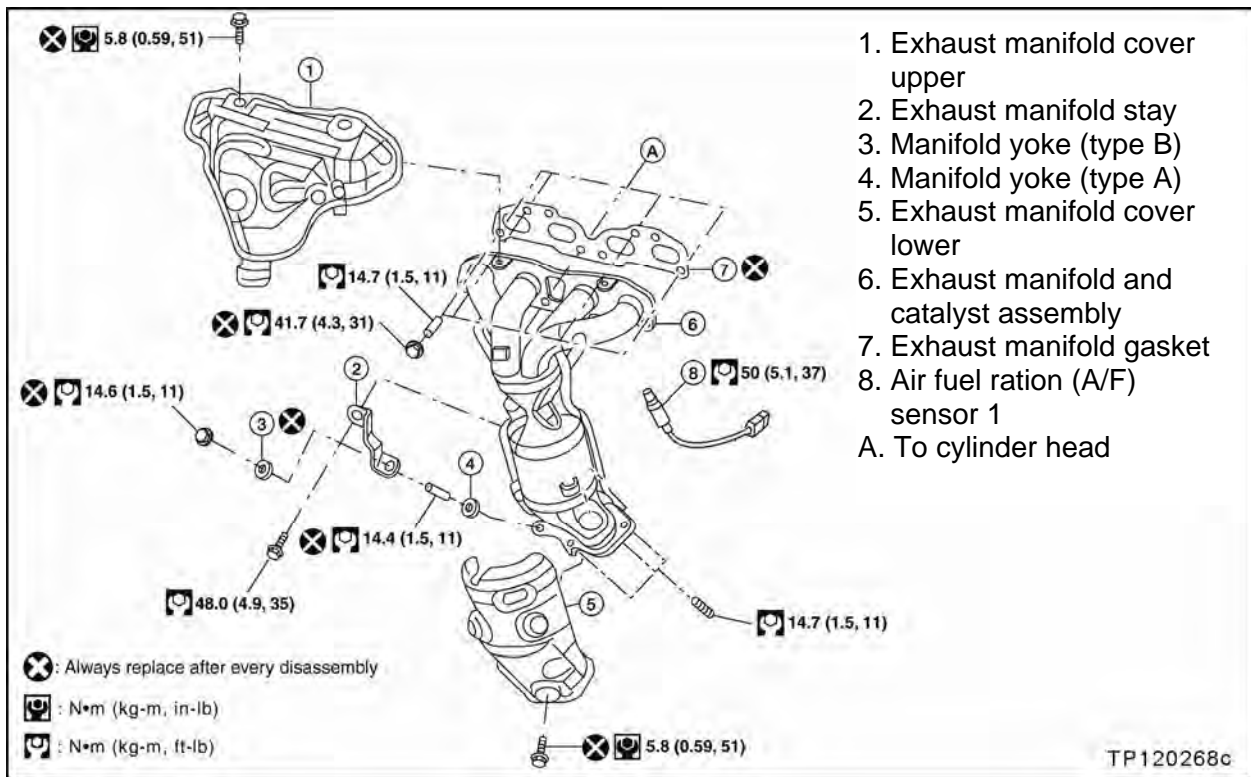

Figure M8

a. Disconnect the Air Fuel (A/F) sensor harness and remove the A/F sensor from the exhaust manifold.

- If the sensor is seized in the manifold, refer to NTB10-009 for sensor removal.

**CAUTION:** Do not drop the A/F sensor.

b. Remove the lower exhaust manifold cover.

c. Remove the upper exhaust manifold cover.

d. Remove the exhaust manifold stay **and discard**.

- Manifold stay is held on with a bolt to the engine and nut to the manifold.
- The stay will not be reinstalled – **discard the exhaust manifold stay**.

e. Remove the exhaust manifold nuts in the order shown.

f. Remove the exhaust manifold from the vehicle.

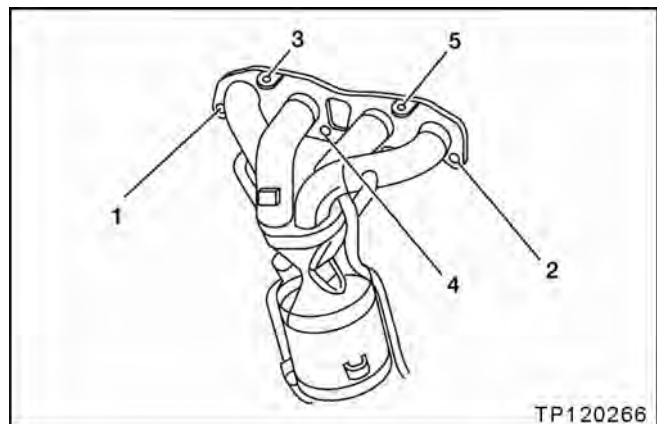

Figure M9

13. Remove the exhaust manifold gasket.

14. Clean any exhaust manifold gasket residue from the engine head.

15. Install a new exhaust manifold gasket.

**NOTE:** The exhaust manifold and gasket must be used as a matched set. Refer to the Parts Information for part number details.

16. Swap the 3 studs for the front tube connection from the old exhaust manifold to the new exhaust manifold.

17. Install the new exhaust manifold.

- Use new nuts.
- Torque the nuts in the order shown.
- Torque nuts in two stages:

1<sup>st</sup> stage – 20.0 N•m (2.0 kg-m, **15 ft-lb**)

2<sup>nd</sup> stage – 41.7 N•m (4.3 kg-m, **31 ft-lb**)

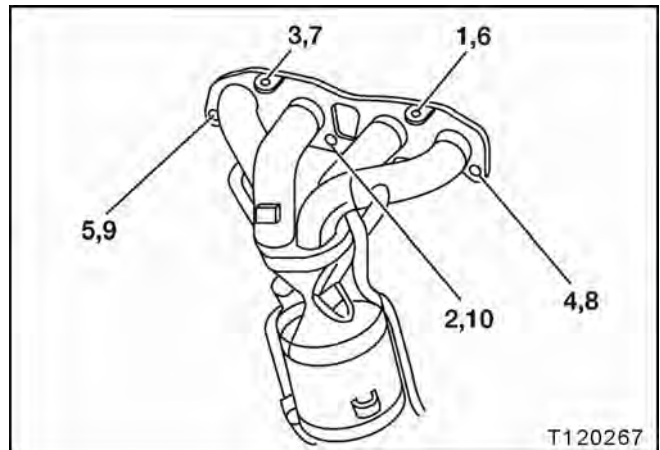

Figure M10

18. Reinstall all other parts in reverse order.

- Refer to Figures M8 - page 17, M7 - page 16, and T3 - page 12 for torque specifications.
- Use new bolts for Heat shield attachment.
- Use new nuts for front tube attachment.

19. Reconnect the negative battery cable.

20. Set the clock and the radio station presets.

21. If equipped; reset customer's settings for the ATC (Automatic Temperature Control) system. (Refer to the Service Manual as needed.)

22. Initialize auto-up power windows as follows:

- a. Turn the ignition ON (keep the transmission in Park and the parking brake applied).
- b. Close the door.
- c. Operate the power window switch to fully open the window.
- d. Pull UP and continue to pull UP on the power window switch to fully close the window.
- e. Continue pulling the power window switch UP for 4 seconds after glass stops at fully closed position.
- f. Check that auto-up function operates normally.

## ECM Reprogram

### NOTE:

- Most instructions for reprogramming with CONSULT-III plus (C-III plus) are displayed on the CONSULT PC screen.
- If you are not familiar with the reprogramming procedure, **click here**. This will link you to the "CONSULT- III plus (C-III plus) Reprogramming" general procedure.
- Take the vehicle for a 10 minute drive in order to meet the following Idle Air Volume Learn (IAVL) conditions:
  - Engine coolant temperature: 70 -100°C (158 -212°F)
  - Battery voltage: More than 12.9V (At idle)
  - Transmission: Warmed up



Figure C

**NOTE:** After reprogramming is complete, you will be required to perform Throttle Valve Closed Position, Idle Air Volume Learn, Accelerator Closed Position, and DTC erase. The above conditions are required for IAVL to complete

### CAUTION:

- Connect a battery charger to the vehicle battery. If the vehicle battery voltage drops below 12.0V or above 15.5V during reprogramming, the ECM may be damaged.
- Be sure to turn OFF all vehicle electrical loads. If a vehicle electrical load remains ON, the ECM may be damaged.
- Be sure to connect the AC Adapter. If the CONSULT PC battery voltage drops during reprogramming, the process will be interrupted and the ECM may be damaged.
- Turn off all external Bluetooth® devices (e.g., cell phones, printers, etc.) within range of the CONSULT PC and the VI. If Bluetooth® signal waves are within range of the CONSULT PC during reprogramming, reprogramming may be interrupted and the ECM may be damaged.

1. Connect the CONSULT PC to the vehicle to begin the reprogramming procedure.
2. Open ASIST on the CONSULT PC and start C-III plus.
3. Wait for the plus VI to be recognized / connected.
  - Serial number will display when the plus VI is recognized / connected.
4. Select **Re/programming, Configuration**.

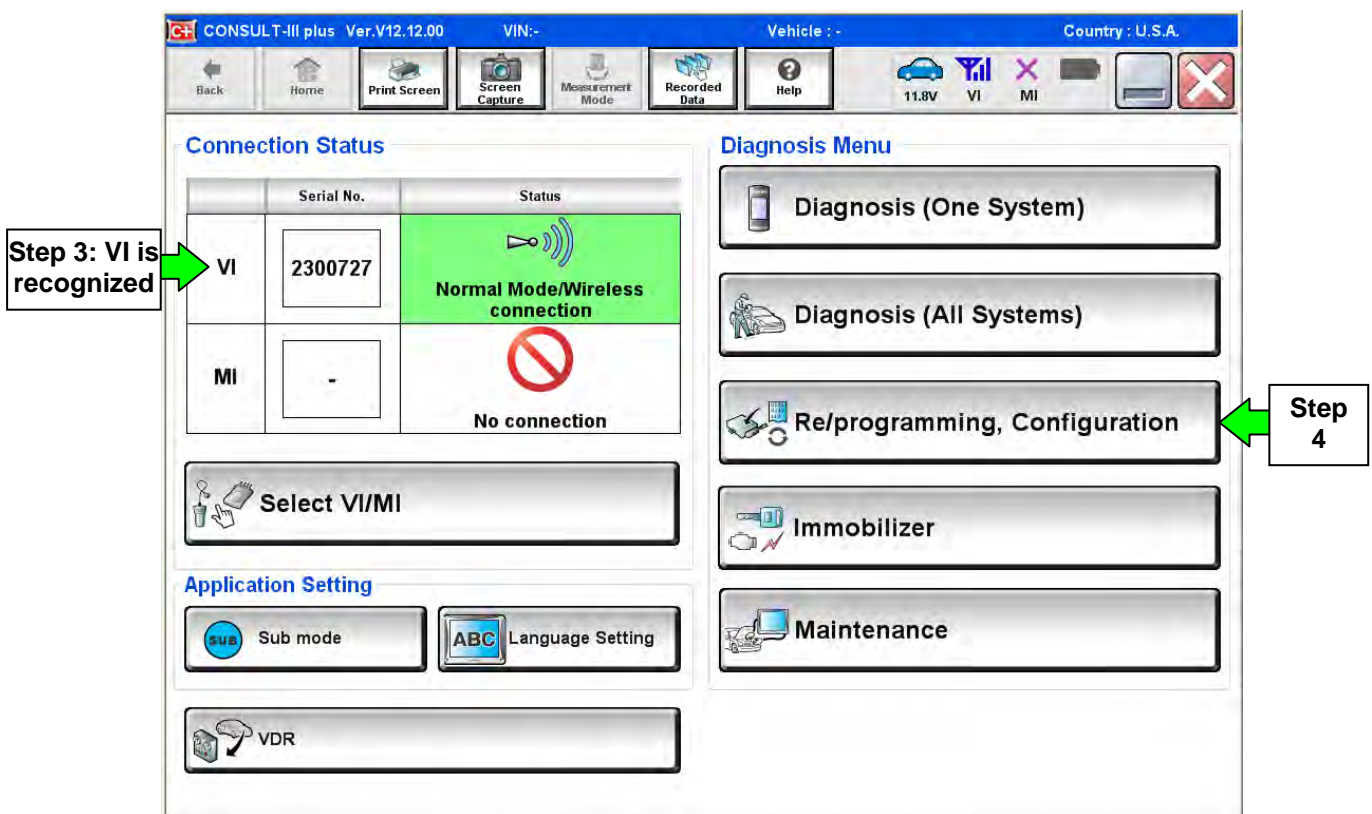

Figure 1

5. Follow the on-screen instructions and navigate the C-III plus to the screen shown in Figure 2 on the next page.

6. When you get to the screen shown in Figure 2, confirm reprogramming is needed as follows.

A. Find the ECM **Part Number** and write it on the repair order.

**NOTE:** This is the current ECM Part Number (P/N).

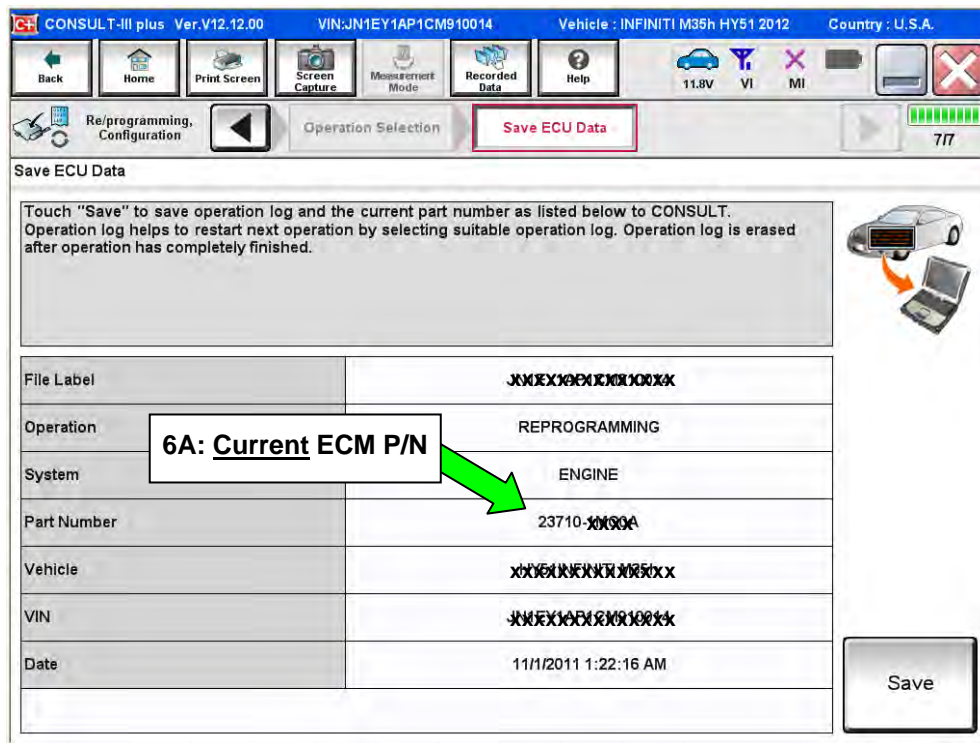

Figure 2

B. Compare the P/N you wrote down to the numbers in the **Current ECM Part Number** column in **Table A** below.

- If there is a match, continue with the reprogramming procedure.
- If there is not a match, reprogramming is not needed. Close C-III plus and disconnect from the vehicle.

**Table A**

MODEL	Current ECM Part Number: 23710-
2009 QR25DE SULEV	ZN67A, ZN67B, ZN67C
	ZN68A, ZN68B, ZN68C

7. Follow the on-screen instructions to navigate C-III plus and reprogram the ECM.

**NOTE:**

- In some cases, more than one new P/N for reprogramming is available.
  - In this case, the screen in Figure 3 displays.
  - Select and use the reprogramming option that **does not** have the message “Caution! Use ONLY with NTBXX-XXX”.
- If you get this screen and it is blank (no reprogramming listed), it means there is no reprogramming available for this vehicle. Close C-III plus and disconnect from the vehicle.

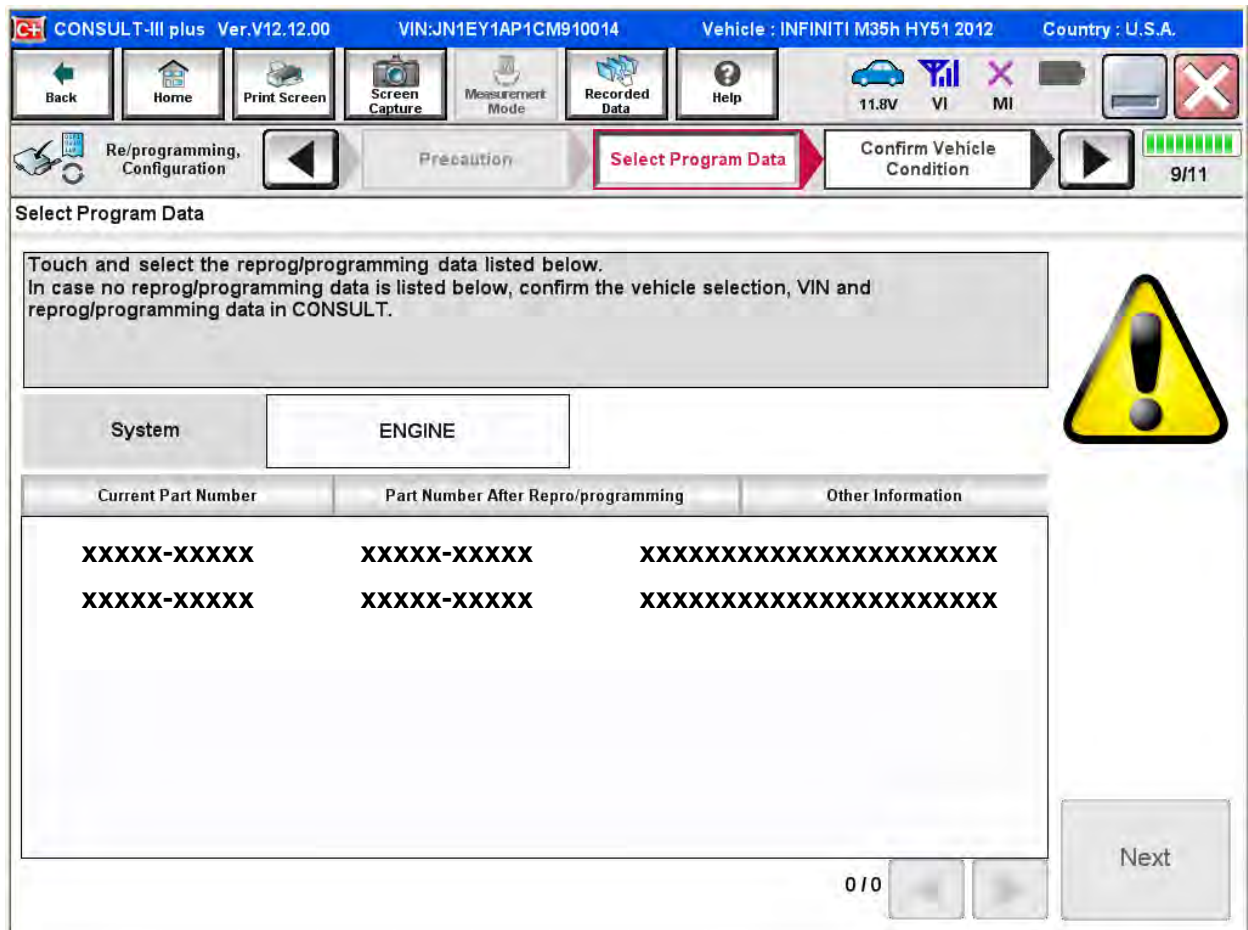

Figure 3

8. When the screen in Figure 4 displays, reprogramming is complete.

**NOTE:** If the screen in Figure 4 does not display (reprogramming does not complete), refer to the information on the next page.

9. Disconnect the battery charger from the vehicle.

10. Select **Next**.

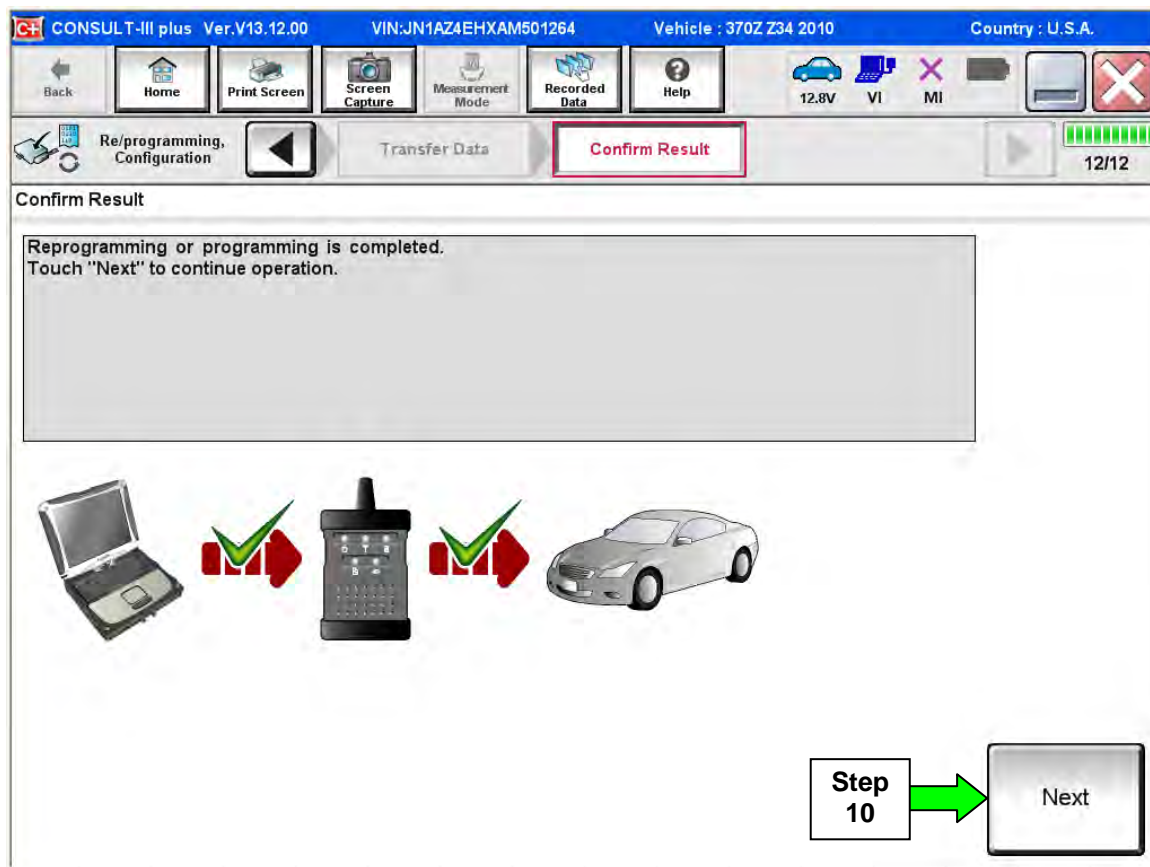

Figure 4

**NOTE:**

- In the next steps (page 26), you will perform Throttle Valve Closed Position, Idle Air Volume Learn, Accelerator Closed Position, and DTC erase.
- These operations are required before C-III plus will provide the final reprogramming confirmation report.



If reprogramming does not complete and the “!?” symbol displays as shown in Figure 5:

- Check battery voltage (12.0 – 15.5V).
- Ignition is ON, Ready Mode is OFF.
- External Bluetooth® devices are OFF.
- All electrical loads are OFF.
- **Select Retry and follow the on screen instructions.**

**NOTE:** Retry may not go through on first attempt and can be selected more than once.

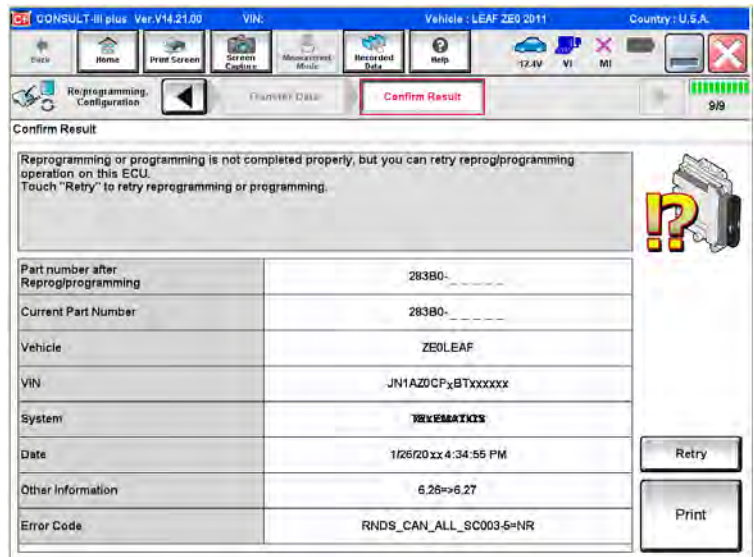

Figure 5

If reprogramming does not complete and the “X” symbol displays as shown in Figure 6:

- Check battery voltage (12.0 – 15.5V).
- CONSULT A/C adapter is plugged in.
- Ignition is ON, Ready Mode is OFF.
- Transmission in Park.
- All C-III plus / plus VI cables are securely connected.
- All C-III plus updates are installed.
- **Select Home, and then restart the reprogram procedure from the beginning.**

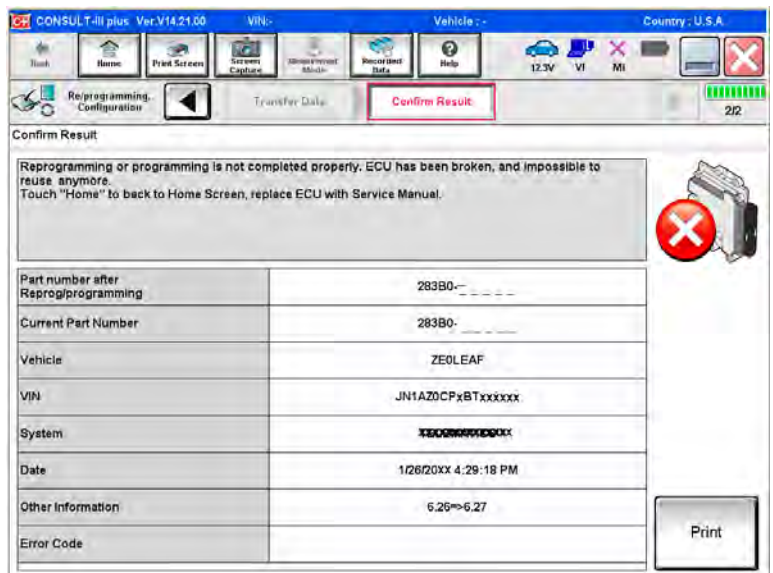

Figure 6

11. Follow the on-screen instructions to perform the following:

- **Throttle Valve Closed Position**
- **Idle Air Volume Learn (IAVL)**

**NOTE:**

- **Listed below are the conditions required for IAVL to complete.**
- **If IAVL does not complete within a few minutes, a condition may be out of range.**
  - Engine coolant temperature: 70 -100° C (158 -212°F)
  - Battery voltage: More than 12.9V (At idle)
  - Selector lever: P or N
  - Electric load switch: OFF (Air conditioner, headlamp, rear window defogger)
  - Steering wheel: Neutral (Straight-ahead position)
  - Vehicle speed: Stopped
  - Transmission: Warmed up (for CVT – ATF TEMP SEN less than 0.9V)
- **Accelerator Pedal Close Position Learning**
- **Erase DTCs**

Continue to the next page.

12. When the entire reprogramming process is complete, the screen in Figure 7 will display.
13. Verify the before and after part numbers are different.
14. Print a copy of this screen (Figure 7) and attach it to the repair order for warranty documentation.
15. Select **Confirm**.

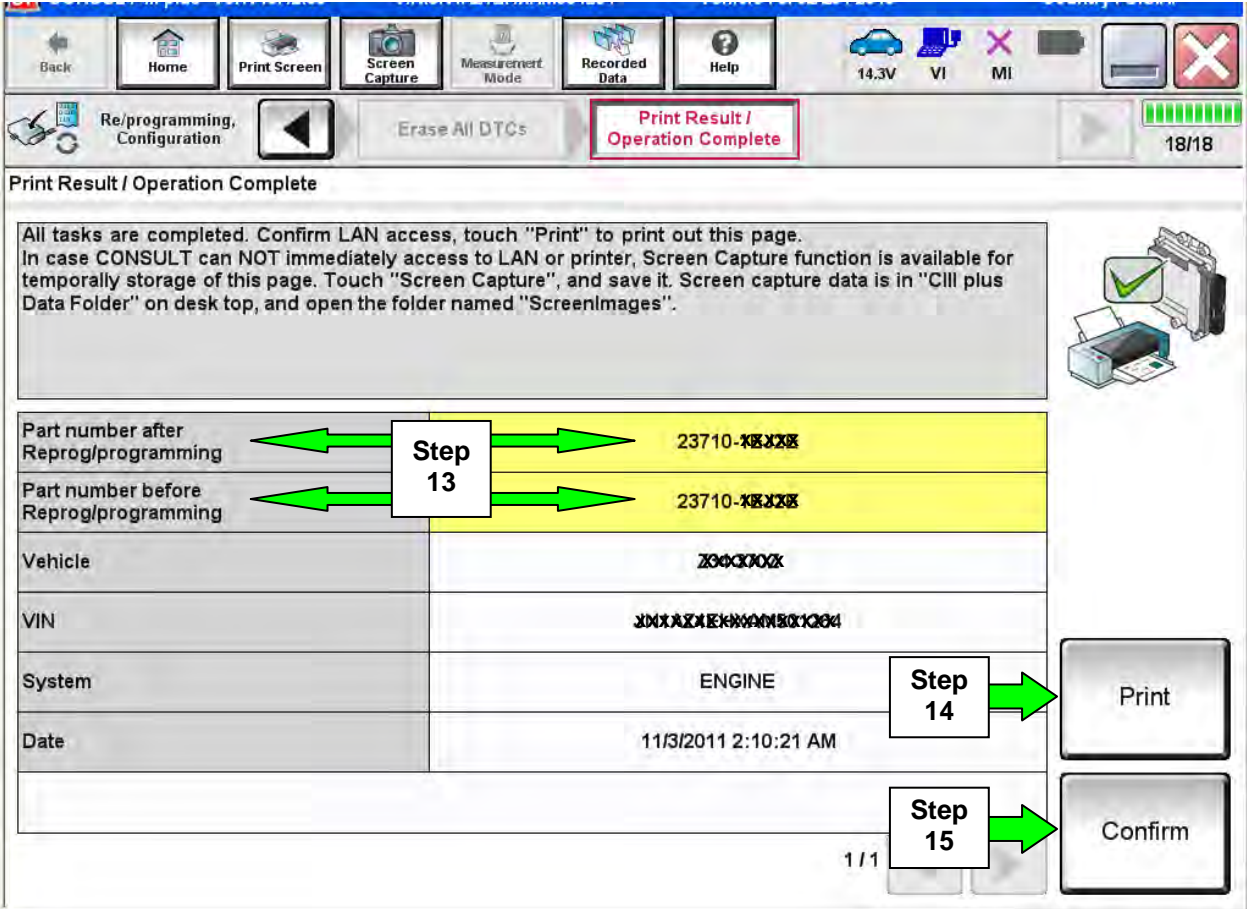

Figure 7

16. Close C-III plus.
17. Turn the ignition OFF.
18. Disconnect the plus VI from the vehicle.
19. Test drive the vehicle and make sure it operates correctly and the MIL is OFF.
  - If the MIL comes ON, go to ASIST for further diagnostic information.

## PARTS INFORMATION

This campaign applies only to 2009 Altima Sedan and Coupe (C/L32) with SULEV (California Specification) 2.5 engine.

DESCRIPTION		PART NUMBER	QTY
Exhaust Gasket (Front tube to center tube)		20692-65J00	1
Front Exhaust Tube W/Catalyst		20010-ZX10A	1; if needed
Exhaust Gasket (Front tube to manifold)		20691-19U00	1: (1)
Nuts (Front tube to exhaust manifold)		01223-N0021	3: (1)
<b>Must be used as a set</b>	Exhaust Manifold	140E2-JA92E *	1; if needed
	Exhaust Manifold Gasket	14036-3TA0B *	1: (2)
Nut (Exhaust manifold to engine head)		14094-JG30A	5: (2)
Bolts (Upper heat shield to exhaust manifold)		14069-JD00A	4: (2)
Bolts (Lower heat shield to exhaust manifold)		14069-ZN50A	8: (2)

\* Your dealer may have exhaust manifolds and gaskets with part numbers 14002-JA91E Manifold / 14036-JA00A Gasket in parts inventory. These exhaust manifolds and gaskets can also be used for this repair as long as they are used together as a set.

- (1) If exhaust manifold or front tube is replaced or removed (single use component).  
 (2) If exhaust manifold is replaced or removed (single use component).

### Catalytic Converter Recycling Program

- The Catalytic Converter Recycling Program allows Nissan to recycle the precious metals contained within catalytic converters.
- Refer to the latest version of the Nissan Parts and Service Bulletin NPSB/10-007 for additional details regarding this program.

## CLAIMS INFORMATION

Submit a Campaign (CM) line claim using the following claims coding:

CAMPAIGN (CM) I.D. #	DESCRIPTION	OP CODE	FRT
PC130	Reprogram ECM and leak check exhaust manifold & front exhaust tube, no leak found	PC1300 (1)	0.7 hrs

(1) This OP-CODE can only be used for vehicles with less than 50,000 miles.

---

---

CAMPAIGN (CM) I.D. #	DESCRIPTION	OP CODE	FRT
PC130	Reprogram ECM and leak check exhaust manifold & front exhaust tube, replace exhaust manifold.	PC1301	1.8 hrs

---

---

CAMPAIGN (CM) I.D. #	DESCRIPTION	OP CODE	FRT
PC130	Reprogram ECM and leak check exhaust manifold & front exhaust tube, replace front exhaust tube (1)	PC1302 (1)	1.0 hrs

(1) This OP-CODE can only be used for vehicles with less than 50,000 miles.

---

---

CAMPAIGN (CM) I.D. #	DESCRIPTION	OP CODE	FRT
PC130	Reprogram ECM and leak check exhaust manifold & front exhaust tube, replace exhaust manifold and front exhaust tube.	PC1303	2.1 hrs

---

---

CAMPAIGN (CM) I.D. #	DESCRIPTION	OP CODE	FRT
PC130	Reprogram ECM and leak check exhaust manifold & front exhaust tube, replace front exhaust tube gaskets.	PC1304 (1)	1.0 hrs

(1) This OP-CODE can only be used for vehicles with less than 50,000 miles.

---

---

CAMPAIGN (CM) I.D. #	DESCRIPTION	OP CODE	FRT
PC130	Reprogram ECM and leak check exhaust manifold & front exhaust tube, replace exhaust manifold gaskets.	PC1305 (1)	1.8 hrs

(1) This OP-CODE can only be used for vehicles with less than 50,000 miles.

## OWNER'S LETTER

For State of California owners:

Dear Nissan Altima Owner:

Nissan has discovered that your model year 2009 Altima may be equipped with an improperly calibrated Engine Control Module (ECM) that may incorrectly detect engine valve closure as engine knock. Due to this issue you may experience some minor drivability symptoms and a slight decrease in fuel economy under certain driving conditions.

You should also be aware that if your vehicle is not repaired it will fail a Smog Check test in those areas of California where such testing is required under state law. The California Department of Motor Vehicles, in conjunction with the Air Resources Board, has implemented the Registration Renewal/Recall Tie-In Program, which requires affected vehicles registered in California to complete the recall before the DMV will issue a registration or renewal.

### **What Nissan Will Do**

To correct this condition, Nissan is conducting an Emission Recall Campaign to reprogram the Engine Control Module in your vehicle. For vehicles with greater than 50,000 miles, the manifold catalyst will also be replaced due to possible prolonged exposure to higher than anticipated exhaust gas temperatures. Any cracked manifold catalyst or front exhaust tube with catalyst will be replaced regardless of vehicle mileage. This free ECM reprogramming service should take about one hour to complete, but your Nissan dealer may require your vehicle for a longer period of time if catalysts need to be replaced or based upon their work schedule. **To ensure the least inconvenience for you, it is important that you have an appointment before bringing your vehicle to the dealer for service.**

Your vehicle is eligible for this free service regardless of whether non-original parts were used for previous service and repairs, or if the service was performed by a repair facility other than a Nissan dealer.

### **What You Should Do**

Contact your Nissan dealer at your convenience in order to arrange an appointment to have your vehicle repaired beginning on October 15, 2012. Please bring this notice with you when you keep your service appointment. Instructions have been sent to your Nissan dealer.

If the retailer fails, or is unable to complete the modifications free of charge, you may contact the National Consumer Affairs Department, Nissan North America, Inc., P.O. Box 685003, Franklin, TN 37068-5003. The toll free number is 1-800-NISSAN1 (1-800-647-7261).

Thank you for your cooperation. We are indeed sorry for any inconvenience this may cause you.

For non-California owners:

Dear Nissan Altima Owner:

Nissan has discovered that your Altima may be equipped with an improperly calibrated Engine Control Module (ECM) that may incorrectly detect engine valve closure as engine knock. Due to this issue you may experience some minor drivability symptoms and a slight decrease in fuel economy under certain driving conditions.

### **What Nissan Will Do**

To correct this condition, Nissan is conducting an Emission Recall Campaign to reprogram the Engine Control Module in your vehicle. For vehicles with greater than 50,000 miles, the manifold catalyst will also be replaced due to possible prolonged exposure to higher than anticipated exhaust gas temperatures. Any cracked manifold catalyst or front exhaust tube with catalyst will be replaced regardless of vehicle mileage. This free ECM reprogramming service should take about one hour to complete, but your Nissan dealer may require your vehicle for a longer period of time if catalysts need to be replaced or based upon their work schedule.

### **What You Should Do**

Contact your Nissan dealer at your convenience in order to arrange an appointment to have your vehicle repaired. Please bring this notice with you when you keep your service appointment. Instructions have been sent to your Nissan dealer.

If the retailer fails, or is unable to complete the modifications free of charge, you may contact the National Consumer Affairs Department, Nissan North America, Inc., P.O. Box 685003, Franklin, TN 37068-5003. The toll free number is 1-800-NISSAN1 (1-800-647-7261).

Thank you for your cooperation. We are indeed sorry for any inconvenience this may cause you.

