



Service Bulletin No. 390

MODEL E4500 / J4500 Series Coaches	TYPE Field Change Program	SECTION/GROUP 3 – Body	DATE Aug. 3, 2012
SUBJECT DRAIN HOLES IN DRIVE AXLE SUSPENSION SUPPORT STRUCTURE			
CONDITIONS			

Customer Complaint:

Motor Coach Industries ("MCI") has become aware that water may accumulate in the drive axle suspension support structure in certain E4500 and J4500 model coaches, which could cause support structure damage due to expansion when operating the coach in freezing temperatures.

Cause:

The cause is due to the absence of drainage holes in the drive axle suspension support structure.

Corrective Action:

MCI strongly encourages owners of the E4500 and J4500 model coaches listed in the table below to implement the steps in this procedure at the next oil change, or within three (3) months from the date on this bulletin (whichever interval occurs first).

63335	63379	63385 to 63398	63685	63726
64249 to 64253	64328 to 64332	64717	64773	64952
64965	64967	64969	64971	64973
64975	64977	64986	64987	64989
64999	65001	65006	65011	65013 to 65033
65035 to 66160	66162 to 66181			

Service Procedure:

⚠ WARNING

Read this entire procedure before beginning work.

Use Safe Shop Practices At All Times.

⚠ WARNING

To avoid personal injury, never enter or perform work in the engine compartment prior to positioning the ENGINE RUN and ENGINE START switches on the engine compartment remote control box to the OFF position. Allow enough time for components to cool down prior to working in the engine compartment.

1. For E / J model coaches prior to 65013, turn the main battery disconnect switch to the OFF position. For E / J model coaches effective with 65013, activate the disconnect feature of the main battery disconnect (MDS) system by pressing (for one second only) the momentary toggle switch on the MDS module to OFF. An audible click can be heard from the main solenoids in the MDS module. Position the rotary switch to the DOWN (OFF) position.
2. Chock both sides of the tires.
3. Locate the drive axle support structure.

- Using a caliper, measure a clean area of the outside fore–aft dimension on each of the two (2) drive axle support structure cross tubes.

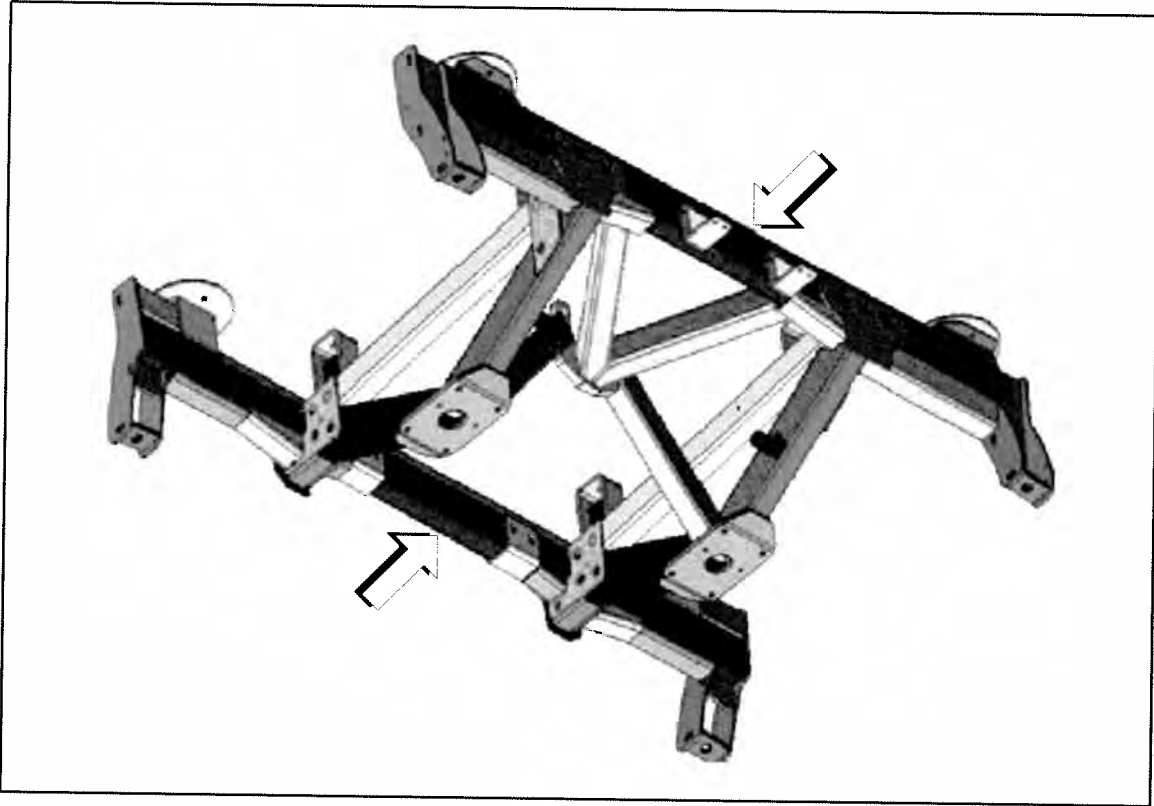

Figure 1. Drive axle support structure cross tubes.

NOTICE

In the event that either of the fore–aft measurements exceeds 3.18 inches, without the presence of rust, dirt or debris, or if a crack is present anywhere on either cross tube, contact the MCI Fleet Support Technical Center at 1-800-241-2947 for further information, before proceeding any further.

If neither of the foregoing conditions exists, proceed to Step 5.

NOTICE

When drilling holes in the tubing, trapped water may drain out of the hole.

5. With the coach on a lift or over a pit, use a 0.250 inch drill bit to drill a hole in the bottom face of each of the cross tubes as shown in Figures 2 and 3.

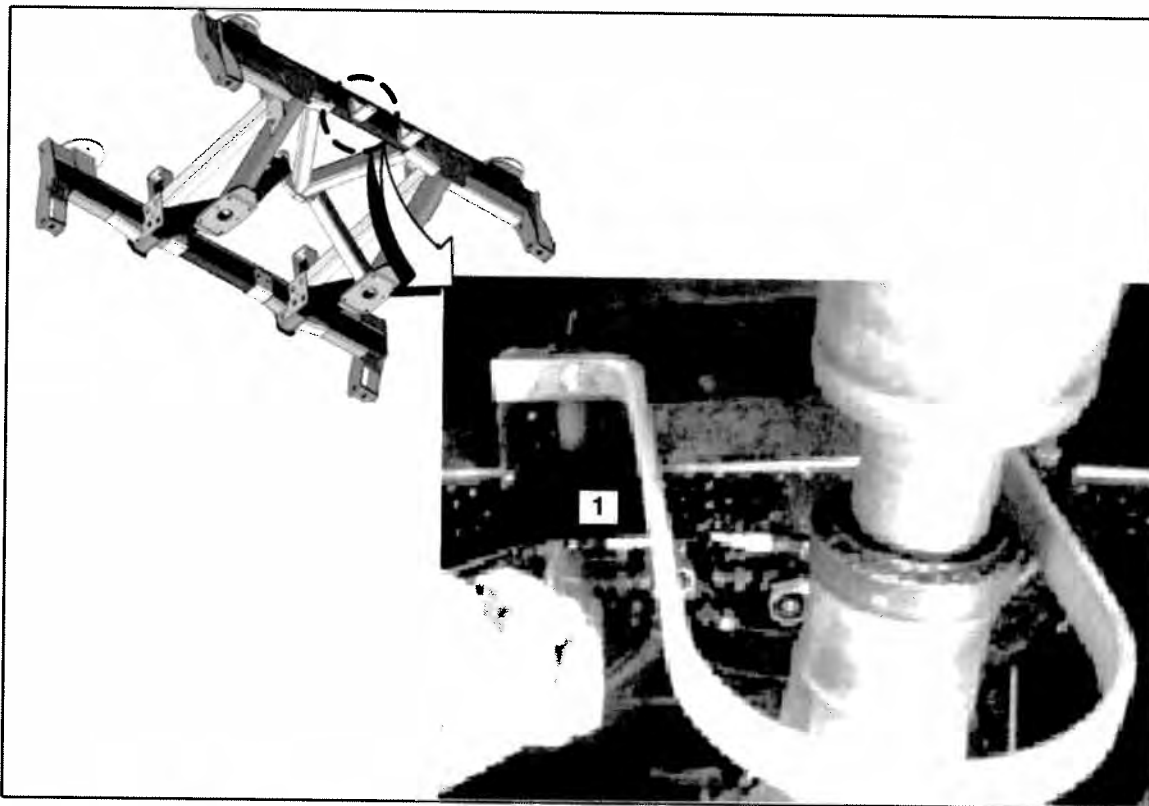

Figure 2. Rear of drive suspension support structure.

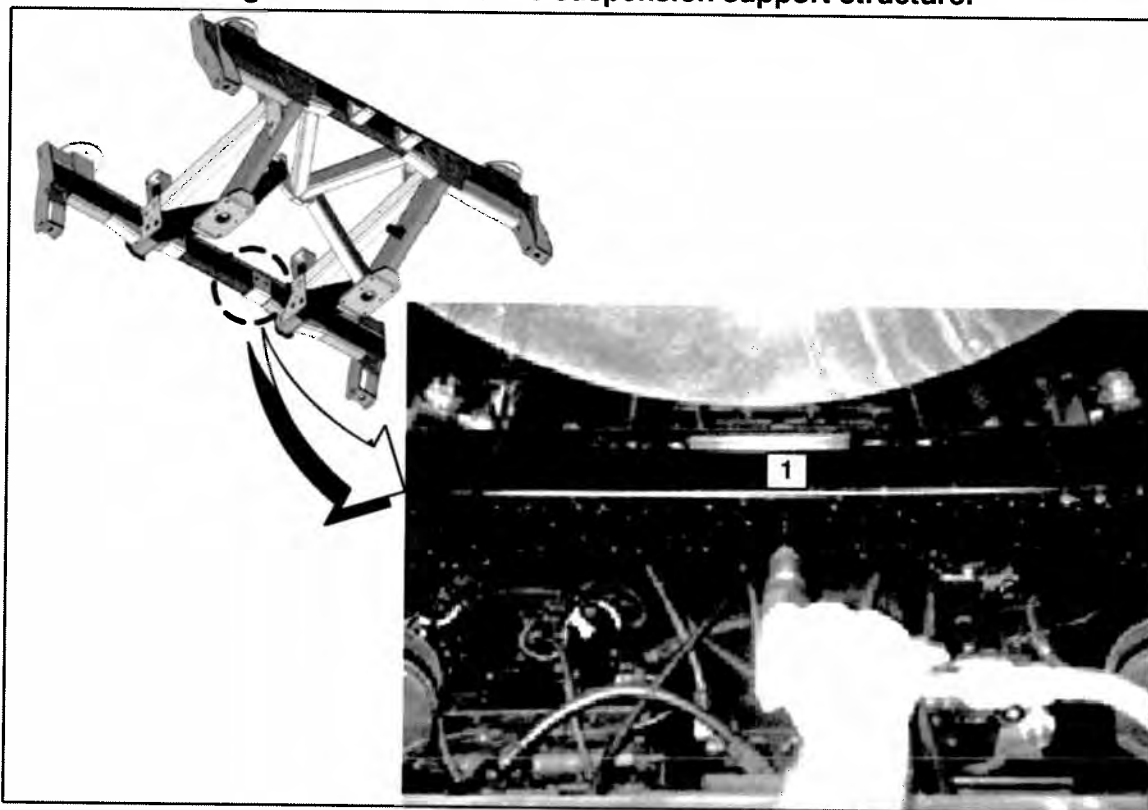

Figure 3. Front of drive suspension support structure.

ITEM	DESCRIPTION
1	Drill a 0.250 inch hole in the bottom face of the cross-tubes.

6. With the coach in the High Ride position, use a 0.250 inch drill bit to drill a hole 0.125 inch above the weld, directly underneath the air bag on the vertical face of the tube as shown in Figure 4. Repeat to other side of the tube.

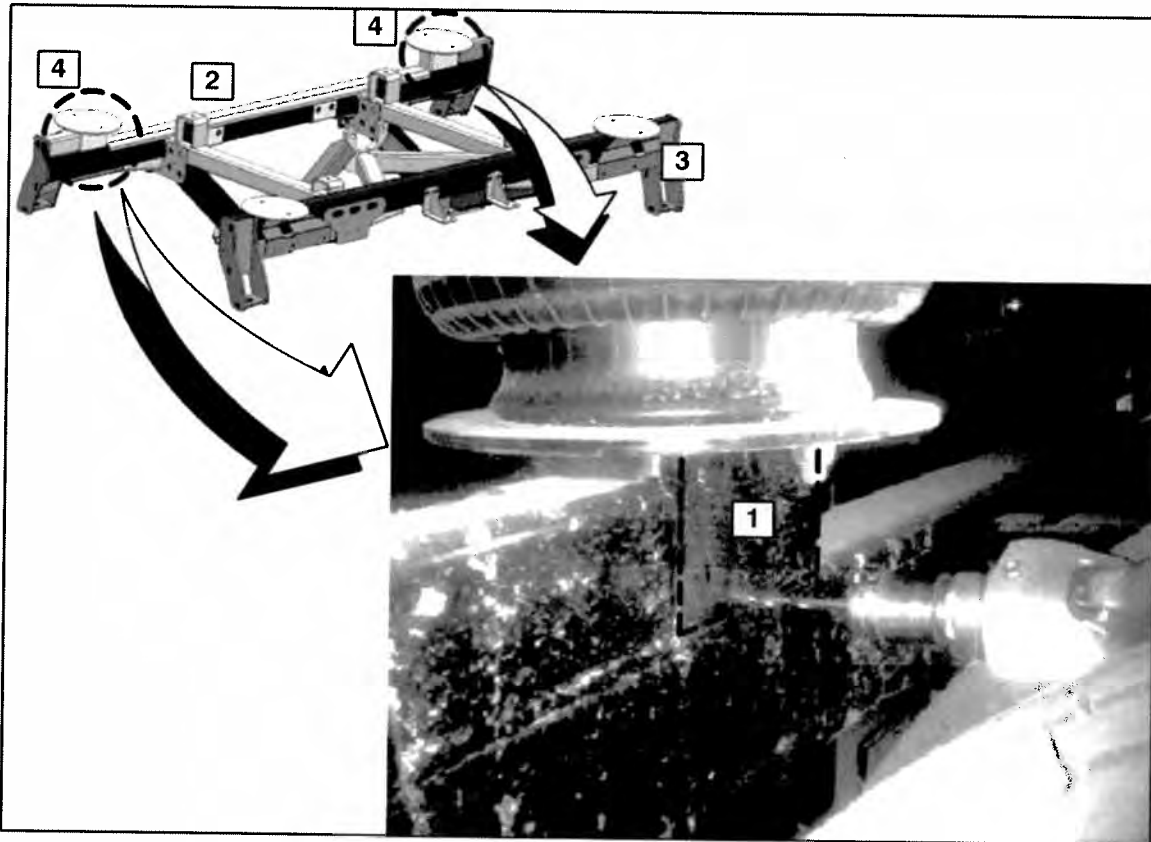

Figure 4. Two (2) drain holes drilled in the drive suspension support structure.

ITEM	DESCRIPTION
1	Drill a 0.250 inch hole 0.125 inch above the weld (in the area shown), directly underneath the air bag on the vertical face of the tube.
2	Front of assembly
3	Rear of assembly
4	Location of the drilled hole

Procedure complete.

Mail or fax the completed limited warranty claim form and verification form to MCI's warranty department, or photocopy and mail to:

MCI Fleet Support
Attn: Warranty Department
7001 Universal Coach Drive
Louisville, KY 40258
Fax Number 1-800-360-8886

to receive credit for the hours used to complete this task. Contact the MCI Fleet Support Technical Center at 1-800-241-2947 for any further information.

Field Change Program Conditions:

No parts are required.

A labor allowance of 0.3 hours will be granted for the procedure of drilling the drain holes on affected E4500 and J4500 Series coaches.

This labor allowance will be credited to your MCI Fleet Support Parts Account on receipt of the attached "MCI Field Change Program Verification Form" and a "Warranty Claim Form" as detailed in your Owner Warranty manual to MCI's Warranty department. A "MCI Field Change Program Verification Form" needs to be submitted for each VIN affected. Photocopy the attached "MCI Field Change Program Verification Form" as required for the number of affected coaches in your fleet.

This program will end on February 17, 2013.

Motor Coach apologizes for any inconvenience resulting from this campaign, but urges you to implement this change as soon as possible.

Sincerely,

Motor Coach Industries



Reliability Driven™

MCI FIELD CHANGE PROGRAM (FCP) VERIFICATION

CONTACT INFORMATION	
CUSTOMER NAME: _____	
(PLEASE PRINT)	
FCP INFORMATION – ONE FORM PER UNIT	
FCP#: _____	Coach Model _____ Model Year _____
COACH SERIAL #: (At least the last 5 digits)	DATE COMPLETED __ / __ / __
MILEAGE:	
<u>IMPORTANT:</u> TO RECEIVE CREDIT FOR ANY ALLOWABLE LABOR CHARGES, THIS VERIFICATION FORM MUST BE RETURNED TO MCI UPON COMPLETION OF THE FCP.	
SUBMITTED BY: (Please Print) _____	
	DATE __ / __ / __
TITLE: (Please Print) _____	
SIGNATURE: _____	
COMMENTS:	

FAX TO: 800-360-8886

MAILING ADDRESS:

MOTOR COACH INDUSTRIES
ATTN: WARRANTY DEPT.
7001 UNIVERSAL COACH DRIVE
LOUISVILLE, KY 40258

MCI part # 03-15-7738C