

General Information

The surge tank must be filled to the "COLDMAX" level on EPA07 and later vehicles with Detroit engines equipped with radiator mounted surge tanks. With a cold engine, check the coolant level and if necessary, add coolant to the surge tank.

Some Gentech low coolant level sensors (part number 06-62384-002) on EPA07 and later vehicles with radiator mounted surge tanks are being misdiagnosed as failed because of a fault code being generated during temporary low coolant level in the surge tank during engine warm-up.

This bulletin provides in-vehicle system testing and sensor troubleshooting procedures to assist in accurately diagnosing Gentech low coolant level sensors. Removal and installation procedures are also provided. It is necessary to remove the sensor in order to troubleshoot it.

There is a known coolant return-flow rate issue with the coolant surge tank. With the coolant level between the "COLDMIN" and "COLDMAX" lines, and when the engine is cold, under certain operating conditions the engine can pull the coolant level down low enough and for long enough to cause a low coolant fault code. This situation can be prevented by adding coolant to the "COLDMAX" line when the system is cold. If a vehicle comes in with a fault code for low coolant, and the coolant level is within spec, fill the coolant to the "COLDMAX" line and check to see if the vehicle still causes a fault code. If this does not solve the issue, the coolant sensor may be defective. Perform the "Initial Test" below to determine if the cause of the fault code is from low coolant, or a bad sensor.

IMPORTANT: When returning the vehicle to service, inform the customer that they need to keep the coolant filled to the "COLDMAX" line to avoid this issue in the future.

Initial Test

1. Park the vehicle on a level surface, shutdown the engine, and set the parking brake. Chock the tires.
2. Allow the engine and coolant to cool to ambient temperature.
3. Fill the surge tank to "COLDMAX". See [Fig. 1](#).
4. Start the engine.
5. When the engine oil pressure reaches operating level, raise the engine rpm to maximum and hold it for 45 seconds.

If a low coolant level fault is generated, follow the steps below to remove and troubleshoot the coolant sensor.

If no fault is generated, return the vehicle to service.

Sensor Removal

The low coolant level sensor is located in the coolant surge tank on EPA07 and later vehicles. See [Fig. 1](#). The low coolant level sensor is assembled with a two-piece housing held together with two locking tabs, one on the top and the other on the bottom. See [Fig. 2](#).

NOTICE

When removing the sensor from the reservoir, do not disengage either of the lock tabs. Disengaging the lock tabs could allow you to remove the internal circuit board from the outer housing. Separating the housings and removing the internal section of the sensor could damage the internal circuit board and destroy evidence needed in the failure analysis process.

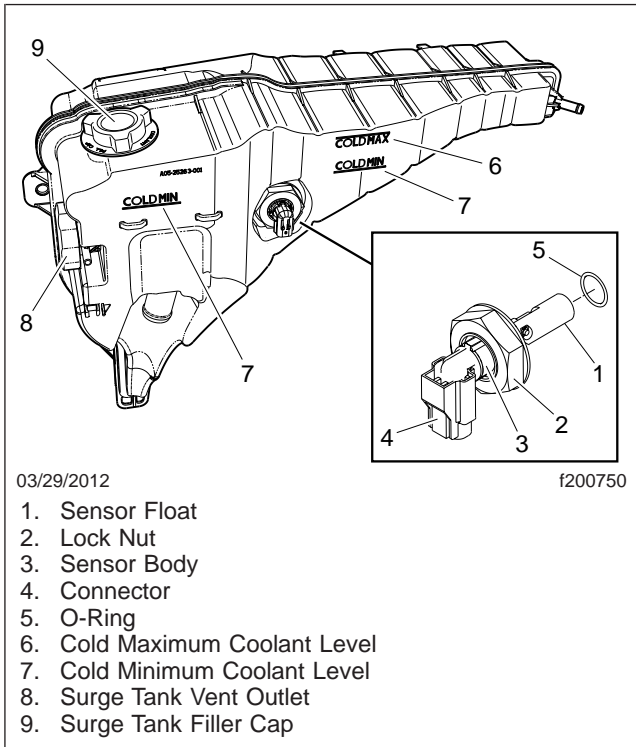

Fig. 1, Low Coolant Level Sensor Installation

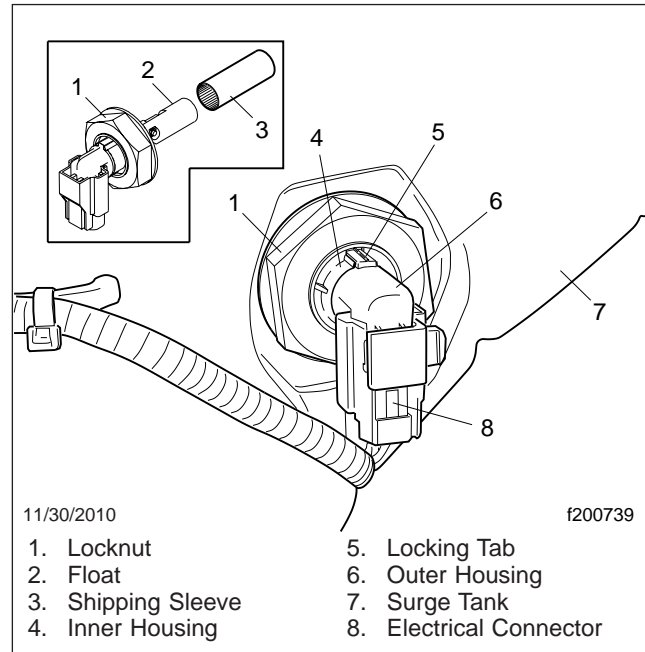

Fig. 2, Low Coolant Level Sensor

1. Park the vehicle on a level surface, shutdown the engine, and set the parking brake. Chock the tires.

⚠ WARNING

Drain the coolant only when the coolant and engine are cool. Draining it when these are hot could cause severe personal injury due to scalding.

2. Allow the engine to cool to ambient temperature.
3. Place a catch pan under the radiator, and drain the coolant to below the sensor if needed.
4. Disconnect the electrical connector from the sensor by releasing the locking tab then pressing on the retaining tab.

NOTICE

When removing the sensor, do not twist the sensor after the locknut is loosened. It will damage the float, and void the warranty.

5. Turn the large black locknut in the counterclockwise direction until it is disengaged from the reservoir, then remove the complete sensor by pulling it straight out.

Troubleshooting

A float with an embedded magnet operates a switch in the sensor body to signal a low or normal level of coolant. Disconnect the wire harness, then, using a digital multi-meter (DMM), test the resistance through the sensor. When the float is up, the switch is closed, the resistance across a good sensor will measure approximately 130Ω. When the float is down, the switch is open, the resistance across a good sensor will measure approximately 1200Ω.

The sensor operation may also be measured in a live circuit by backprobing circuit 440L using a volt meter with the ignition in the "ON" position and the engine not running. When the float is up, a good circuit will measure 1.25±0.5 volts. When the float is down, a good circuit will measure 3.75±0.5 volts.

Common failures of the coolant-level sensor:

- A sticky float due to coolant corrosion/debris.
- The locking tab can break when the sensor is not properly installed in surge tank.
- The float axle can wear out, allowing the magnet to move away from the sensor, or fall off.

Table 1 lists fault codes related to the coolant level sensor.

Coolant Level Sensor Fault Codes			
SPN	FMI	Description	Troubleshooting
111	1	Coolant level is low or engine ECU may need software update	Use the engine manufacturer's diagnostic software program to determine if software or calibration updates are necessary. Check for coolant leaks. Inspect the coolant level in the reservoir and add if it is low. When it is safe to start the engine, inspect the coolant level in the reservoir.
111	3	Coolant level sensor circuit voltage out of range high	Troubleshoot circuit 440L and circuit 440G for a wiring fault between the sensor and the engine ECU. This code indicates the circuit is shorted to a voltage source or that the circuit is high resistance or open.
111	4	Coolant level sensor circuit voltage out of range low	Troubleshoot circuit 440L for a wiring fault. This code indicates the circuit is shorted to ground.
111	17	Coolant level is low	Check for coolant leaks. Inspect the coolant level in the reservoir and add coolant if the cold level is below the "COLDMAX" line. When it is safe to start the engine, inspect the coolant level in the reservoir.
111	18	Coolant level is low	Check for coolant leaks. Inspect the coolant level in the reservoir and add coolant if the cold level is below the "COLDMAX" line. When it is safe to start the engine, inspect the coolant level in the reservoir.
111	19	Coolant level may be low	Check for coolant leaks. Inspect the coolant level in the reservoir and add coolant if the cold level is below the "COLDMAX" line. When it is safe to start the engine, inspect the coolant level in the reservoir.

Table 1, Coolant Level Sensor Fault Codes

Sensor Installation

1. If installing a new sensor, remove the plastic shipping sleeve from the new sensor.

NOTICE

Do not use petroleum based lubricant on the sensor O-ring, it may cause the O-ring to deteriorate and cause a leak.

2. Lubricate the new sensor's O-ring with a small amount of light silicone grease, or some coolant.

3. Carefully position the new sensor so that the tabs are aligned in the surge tank neck. Turn the large black locknut in the clockwise direction until the sensor is securely engaged into the tank.
4. Connect the electrical connector to the sensor.
5. Add coolant to the "**COLDMAX**" line.
6. Clear any fault codes related to the low coolant sensor.

Warranty

This bulletin is informational only. Warranty does not apply.