

Subject: FCCC MT Chassis Air Intake Filter Hose Clamps

**Models Affected: Specific Freightliner Custom Chassis
MT45/55 step van chassis manufactured June 2, 2011, through
August 22, 2011.**

General Information

Daimler Trucks North America LLC, on behalf of its wholly owned subsidiary, Freightliner Custom Chassis Corporation, is initiating Field Service Campaign SF462A to modify the vehicles mentioned above.

Certain vehicles may contain air intake hose clamps not suitable for holding the hose in place.

Air intake hose clamps will be replaced with the correct size clamps.

There are approximately 1,200 vehicles involved.

Additional Repairs

Dealers must complete all outstanding field service campaigns prior to the sale or delivery of a vehicle. A Dealer will be liable for any progressive damage that results from its failure to complete campaigns before sale or delivery of a vehicle.

Owners may be liable for any progressive damage that results from failure to complete campaigns within a reasonable time after receiving notification.

Please contact Warranty Campaigns for consideration of additional charges prior to performing the repair.

Work Instructions

Please refer to the attached work instructions. Prior to performing the campaign, check the vehicle for a completion sticker (Form WAR261).

Replacement Parts

Replacement parts are now available and can be obtained by ordering the kit number listed below from your facing Parts Distribution Center.

If our records show your dealership has ordered any vehicle(s) involved in campaign SF462A, a list of the customers and vehicle identification numbers will be available on AccessFreightliner.com. Please refer to this list when ordering parts for this campaign.

Table 1 - Replacement Parts for SF462A

Campaign Number	Kit Number	Part Description	Part Number	Qty. per Kit	Suggested Wholesale*
SF462A	25-SF462-000	CLAMP-98IN LB-CT,4IN	BRZ B9224 0411FRUB	2 ea	\$14.62 US \$14.91 CAN
		Completion Sticker	WAR261	1 ea	

* Please charge all U.S. and Canadian Direct Warranty Customers the above-listed price for the kit, as they are authorized to perform their own Recalls. This pricing does not apply to Export Distributors.

Table 1

Removed Parts

U. S. and Canadian Dealers, please follow Warranty Failed Parts Tracking shipping instructions for the disposition of all removed parts. Export distributors, please destroy removed parts unless otherwise advised.

Field Service Campaign

Daimler Trucks
North America LLC

March 2012
SF462A

Labor Allowance

Table 2 - Labor Allowance

Campaign Number	Procedure	Time Allowed (hours)	SRT Code	Damage Code
SF462A	Replace air intake hose clamps	0.2	996-0874A	000-Modifiedx

Table 2

IMPORTANT: When the campaign has been completed, locate the base completion label in the appropriate location on the vehicle, and attach the gray completion sticker provided in the field service kit (Form WAR261). If the vehicle does not have a base completion label, clean a spot on the appropriate location of the vehicle and first attach the base completion label (Form WAR259). If a field service kit is not required or there is no completion sticker in the kit, write the campaign number on a blank sticker and attach it to the base completion label.

Claims for Credit

You will be reimbursed for your parts, labor, and handling (landed cost for Export Distributors) by submitting your claim through the Warranty system within 30 days of completing this campaign. Please reference the following information in QuickClaim or OWL:

- Claim type is **Field Service**.
- In the FTL Authorization field, enter the campaign number and appropriate condition code (**SF462A**).
- In the Primary Failed Part Number field, enter **25-SF462-000**.
- In the Parts field, enter the appropriate kit number(s) as shown in the Replacement Parts Table.
- In the Labor field, first enter the appropriate SRT from the Labor Allowance Table. For administrative time, enter SRT 939-0010A for 0.3 hours.
- For OWL, the VMRS Component Code is 001-001-384 and the Cause Code is A1 - Campaign.

This Field Service Campaign will **terminate on March 31, 2013**. Dealers will be notified of any changes to the termination date via Important Campaign Information Letter posted on AccessFreightliner.com.

IMPORTANT: ServicePro or OWL must be viewed prior to beginning work to ensure the vehicle is involved and the campaign has not previously been completed. Also, check for a completion sticker before beginning work.

All claims must be submitted within 30 days of the repair and within 30 days of the termination date of the campaign. U.S. and Canadian Dealers: All excess inventory to be returned to the PDC following the conclusion of the campaign must be returned in resaleable condition to the Memphis PDC within 90 days from the termination date. Please submit a PAR to request return to the Memphis PDC. (Canadian dealers should return the kits to their facing PDC.) Export Distributors: Excess inventory is not returnable.

U.S. and Canadian dealers, contact the Warranty Campaigns Department from 7:00 a.m. to 4:00 p.m. Pacific Time, Monday through Friday, via Web inquiry at AccessFreightliner.com / Support / My Tickets and Submit an Inquiry, or the Customer Assistance Center at (800) 385-4357, after normal business hours, if you have any questions or need additional information. Export distributors submit a Web inquiry or contact your International Service Manager.

Copy of Notice to Owners

Subject: FCCC MT Chassis Air Intake Filter Hose Clamps

Daimler Trucks North America LLC, on behalf of its wholly owned subsidiary, Freightliner Custom Chassis Corporation, is initiating Field Service Campaign SF462A to modify specific Freightliner Custom Chassis MT45/55 step van chassis manufactured June 2, 2011, through August 22, 2011.

Certain vehicles may contain air intake hose clamps not suitable for holding the hose in place.

Air intake hose clamps will be replaced with the correct size clamps.

Please contact an authorized Daimler Trucks North America dealer to arrange to have the campaign performed and to ensure that parts are available at the dealership. To locate an authorized dealer, search online at www.Daimler-TrucksNorthAmerica.com. The campaign will take approximately half an hour and will be performed at no charge to you.

This Field Service Campaign will **terminate on March 31, 2013**. Please make sure the campaign is completed prior to this date. Work completed after this date will be done at the customer's expense.

As stated in the terms of your express limited warranty, Daimler Trucks North America LLC will not pay for any damage caused by failure to properly maintain your vehicle. Daimler Trucks North America LLC considers the work necessary under this campaign to be proper maintenance and will, therefore, not pay for any damage to your vehicle caused by your failure to have the repairs that are the subject of this campaign performed in a reasonable time.

IMPORTANT: When the campaign has been completed on your vehicle, please ensure that a completion sticker has been affixed to your vehicle referencing **SF462**.

Contact the Warranty Campaigns Department at (800) 547-0712, from 7:00 a.m. to 4:00 p.m. Pacific Time, Monday through Friday, e-mail address DTNA.Warranty.Campaigns@Daimler.com, or the Customer Assistance Center at (800) 385-4357, after normal business hours, if you have any questions or need additional information.

WARRANTY CAMPAIGNS DEPARTMENT

Enclosure

March 2012
SF462A

Work Instructions

Subject: FCCC MT Chassis Air Intake Filter Hose Clamps

Models Affected: Specific Freightliner Custom Chassis
MT45/55 step van chassis manufactured June 2, 2011, through
August 22, 2011.

Clamp Replacement

1. Check the base label (Form WAR259) for a completion sticker for SF462A (Form WAR261), indicating this work has been completed. The base label is usually located on the driver's area. If a completion sticker is present, no work is needed. If a completion sticker is not present, proceed to the next step.
2. Park the vehicle on a level surface, shut down the engine, and set the parking brake. Chock the tires.
3. Beginning at one end of the convoluted air intake hose, loosen the hose clamp.
4. Gently pull the convoluted air intake hose off of the air inlet tube and remove the hose clamp. See **Fig. 1**.

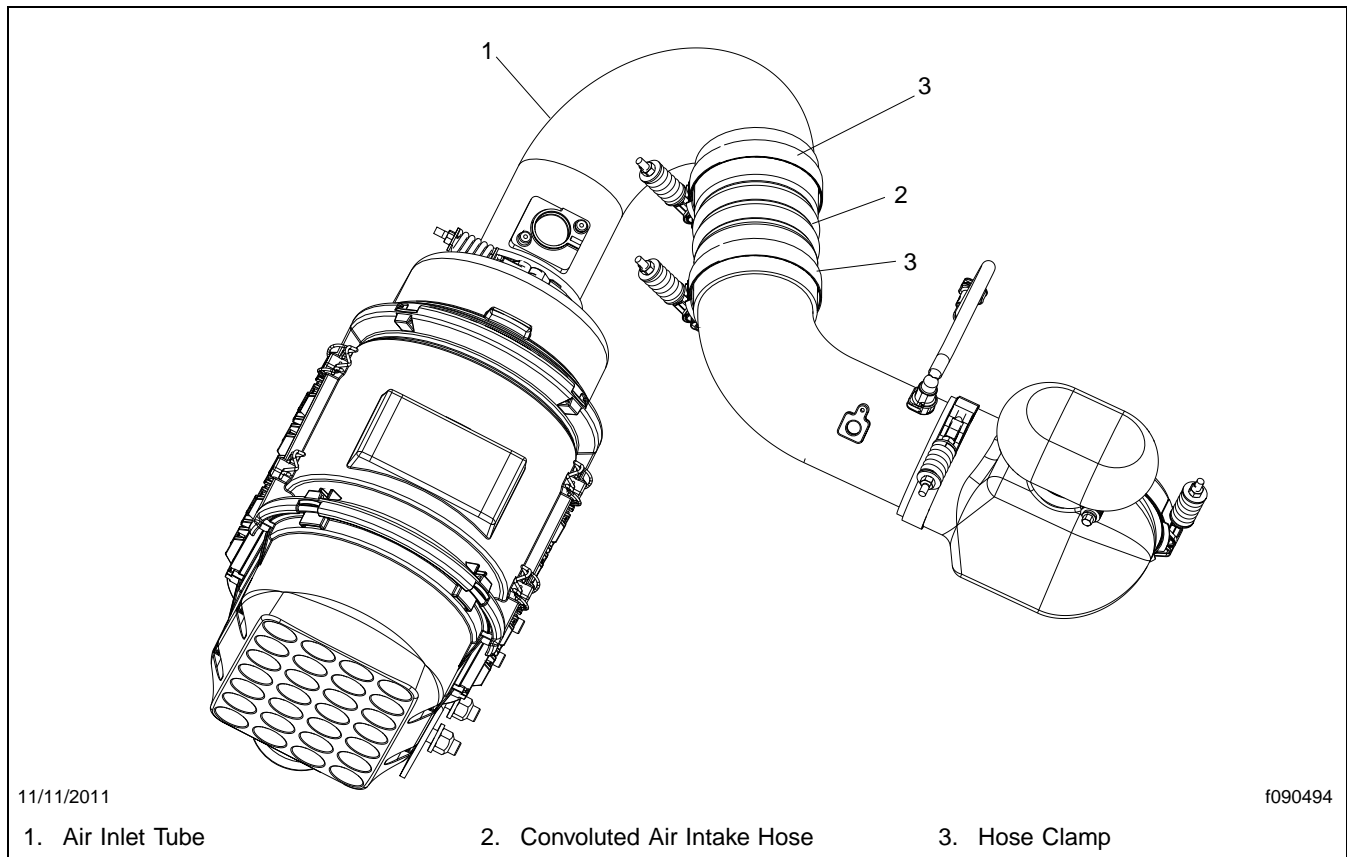

Fig. 1, Air Cleaner Assembly

5. Install, but do not tighten, the new hose clamp from the kit.
6. Install the convoluted air intake hose on the air inlet tube.
7. Position the new hose clamp as shown in **Fig. 1**, then tighten the clamp 98 lbf·in (1107 N·cm).
8. Repeat the steps above at the other end of the convoluted air intake hose to replace the second hose clamp.
9. Clean a spot on the base label (Form WAR259) and attach a grey completion sticker for SF462 (Form WAR261) to indicate the work has been completed.