



Mack Trucks, Inc.
Greensboro, NC USA

Service Program Trucks

This Service Program replaces, "PI0787, Transmission Cooler Line O-Ring", PV729-PI0787 (USA53340) dated (05/2012).

Date	Group	No.	Release	Page
6.2012	491	787	02	1(8)

Transmission Cooler Line O-Ring
CHU, CXU, GU, TD

PI0787, Transmission Cooler Line O-Ring

(June 2012)

Certain MACK trucks built between January 01, 2012 and March 05, 2012 may have been assembled with an incorrect o-ring installed on the transmission cooler line fittings. The transmission cooler line fittings are located at the bottom of the radiator where the transmission cooler lines connect to the transmission. The incorrect o-ring may not seal properly, causing transmission fluid loss and/or premature transmission damage.

Trucks built after March 05, 2012 were assembled with a replacement o-ring on the transmission cooler line fittings. A white dot on the shoulder of the fitting cap indicates a replacement o-ring was installed during assembly. See figure below. Visually inspect the truck for a white dot on the shoulder of the fitting cap. If the white dot is visible, only an inspection for the white dot is required. If the white dot is not visible on the fitting cap, replace the existing o-ring with a new green o-ring (part number 21866819). See the o-ring replacement procedure on page 2.

Note: This bulletin does not apply to MACK Trucks Australia.

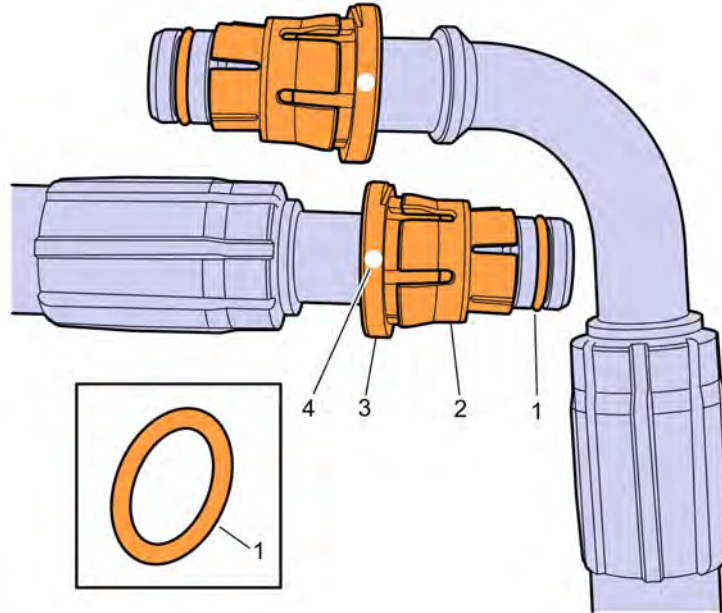

W4072905

Transmission Cooler Line Fitting Components		
Item #	Part Number	Description
1	21866819	O-Ring
2	85129501	Locking Collar
3	85131659	Cap
4	N/A	Visual Inspection Mark (White Dot)

Procedure

You must read and understand the precautions and guidelines in Service Information, group 40, "General Safety Practices, Engine" before performing this procedure. If you are not properly trained and certified in this procedure, ask your supervisor for training before you perform it.

- 1 Apply parking brake and place shift lever in neutral.
- 2 Raise hood or cab.
- 3 Disconnect all cables from the negative (ground) battery terminals to prevent personal injury from electrical shock and prevent damage to electrical components.
- 4 Inspect the transmission cooler line fittings cap for the white dot at the transmission and the radiator.

Note: If a White Dot is visible on the cap, the inspection is complete. If the White Dot is not visible on the cap, continue onto step 5 and replace the four o-rings for the radiator and the transmission fittings.

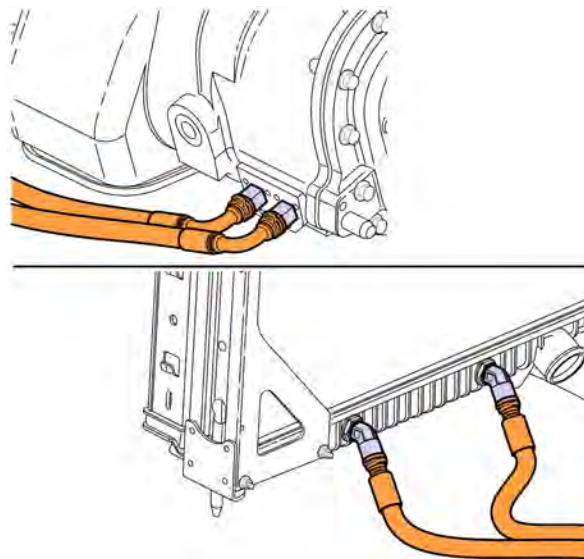

W4072906

- 5 Using a screwdriver or suitable instrument, remove the Sure-Fit clip (20733354).

Note: Use a suitable container to catch any transmission fluid during this procedure.

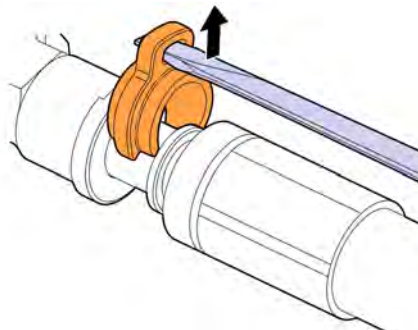

W4072907

- 6 Using a screwdriver or suitable instrument, disengage the cap.

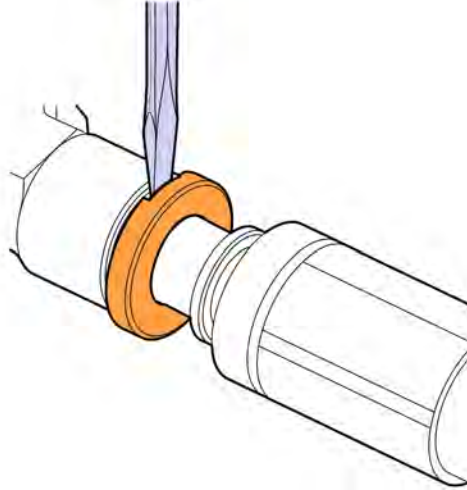

W4072908

- 7 Pull the cap back until it rests against the stop shoulder as shown in the figure below.



W4072909

- 8 Locate the 15 mm (0.6 in) transmission line removal tool (part number 85108826) around the protruding plastic lugs of the locking collar.

Note: Ensure that the internal shoulders of the tool are nearest to the female cavity face and flat and/or parallel to it.

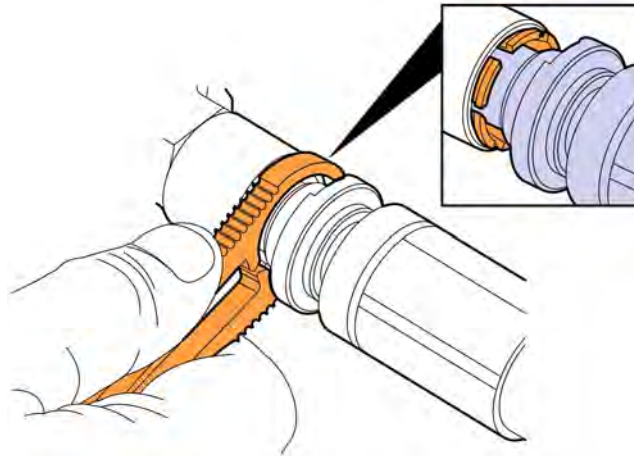

W4072910

- 9 Using one hand close the tool jaws around the protruding plastic lugs, compress the plastic lugs, pull back on the fitting with the other hand, and disconnect the transmission cooler line fitting.

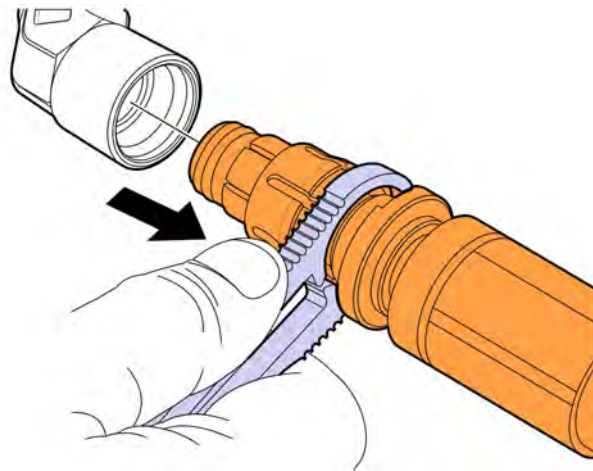

W4072911

- 10 Release the transmission line removal tool and store for future use.
- 11 Clean both the male and female transmission cooler line fittings of any debris or corrosion.
- 12 Remove the existing o-ring.
- 13 Install new green o-ring (part number 21866819).

Note: Lubricate the new o-ring with transmission fluid before installation to prevent binding when the hose is reinserted into the fitting.

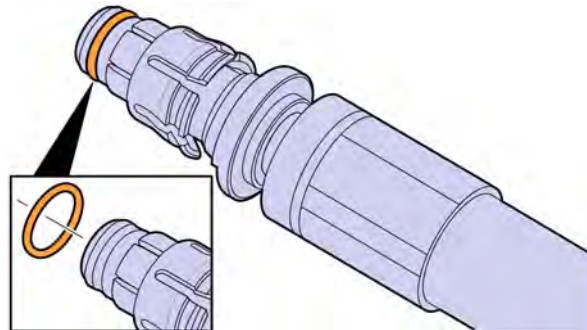

W4072912

- 14 Ensure that the cap is retracted all the way back to the stop shoulder.

Note: Prior to assembly, be sure that all surfaces are clean to ensure proper connection.

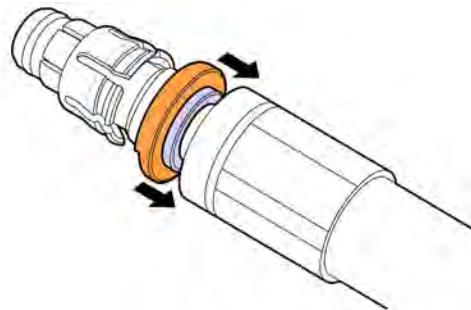

W4072913

- 15 While holding the transmission cooler line, connect the fitting and push until the locking collar snaps into position.

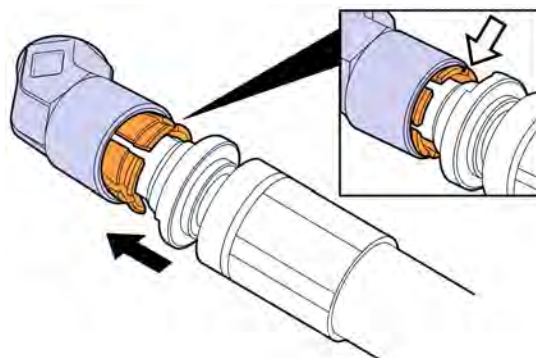

W4072914

16 Slide the cap forward until it snaps onto the protruding lugs of the locking collar.

Note: To ensure a good connection, the cap must be flush with the front face of the female cavity and no part of the locking collar is visible.

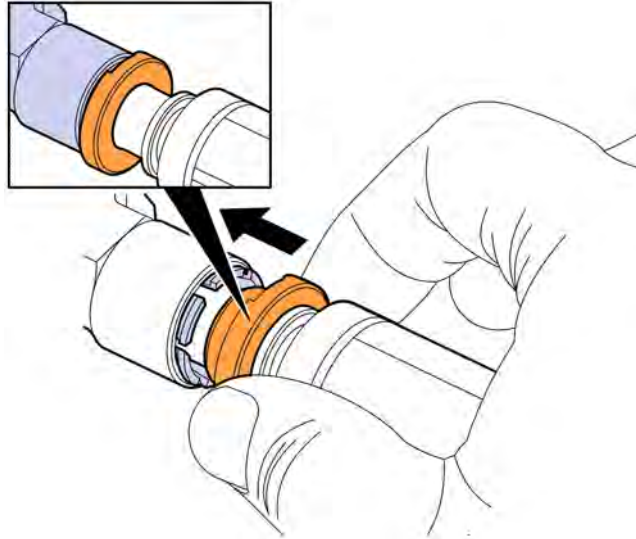

W4072915

17 Install the Sure-Fit clip as shown in figure below.

Note: If there is difficulty installing the Sure-Fit clip, inspect the transmission cooler line for a good connection.

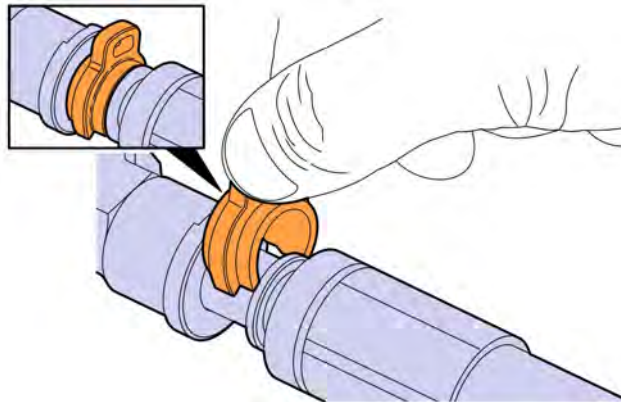

W4072916

18 Reconnect all previously removed cables to the negative (ground) battery terminals.

19 Check transmission fluid levels and replenish if needed.

20 Lower hood or cab.

Note: To signify that the campaign has been completed, using a permanent-type marker (such as a Sharpie®) to write the campaign number (PI0787) and completion date in the spaces provided on the Campaign Completion label located inside the cab as shown in the illustration below. If a label is not already affixed inside the cab, apply a label (part No. TS897) and supply the information as required. Campaign Completion labels are available in packs of 50 and can be ordered by faxing a completed BR313 to Pacesetters Business Services at 610-264-9465.

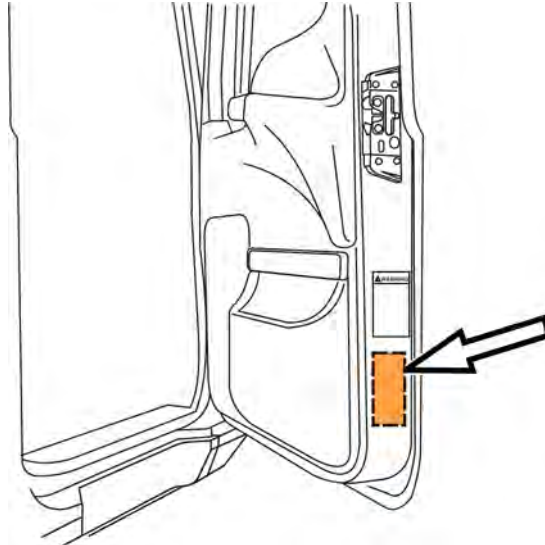

W8034103

Reimbursement

This repair is covered by an authorized Service Program. Reimbursement is obtained through the normal claim handling process.	
Claim Type (used only when uploading from the Dealer Bus. Sys.)	B
Recall Status	
Vehicle inspected, repair not required	1- Inspected OK
Vehicle repaired per instruction	2- Modified per instruction
Labor Code	
Primary Labor Code Time for inspection	3295J-01-96 0.3 hrs.
Primary Labor Code Time for inspection and replacement of the o-ring	3295K-01-96 0.4 hrs.
Time to take charge and determine campaign status	101AA-0A-00 0.3 hr.
Causal Part	20787860
Authorization Number	PI0787
Expiration Date	11-MAY-13

Note: Take Charge Time is not included in the Labor Code for this operation. Take charge may be eligible but can only be used once per repair visit. If vehicle is having other warranty repairs performed, take charge should be charged to the warranty repair, otherwise take charge can be charged to this service program.