



Mack Trucks, Inc.
Greensboro, NC USA

Service Program Trucks

This Field Service Bulletin replaces bulletin, "PI0781, Engine VGT Actuator and TSS Sensor Connector, Relocation", PV729-PI0781 (USA53761) dated (05/2012).

Date	Group	No.	Release	Page
6.2012	255	781	03	1(7)

Engine VGT Actuator and TSS Sensor Connector, Relocation
CHU, CXU, GU, MRU
MP8

PI0781, Engine VGT Actuator and TSS Sensor Connector, Relocation

(June 2012)

A new campaign is available to prevent engine diagnostic trouble codes (DTCs) and missing signal from the Engine Variable Geometry Turbocharger Actuator (Engine VGT Actuator) on MACK MP8 US2010 engines with a Mechanical transmission. This condition is caused by fretting of the connector pins in the engine VGT actuator connector. Relocation of the engine VGT actuator connector and a new mounting arrangement has been developed to eliminate this condition. See the table below for the list of parts required for this campaign.

Note: This bulletin does not apply to MACK Trucks Australia.

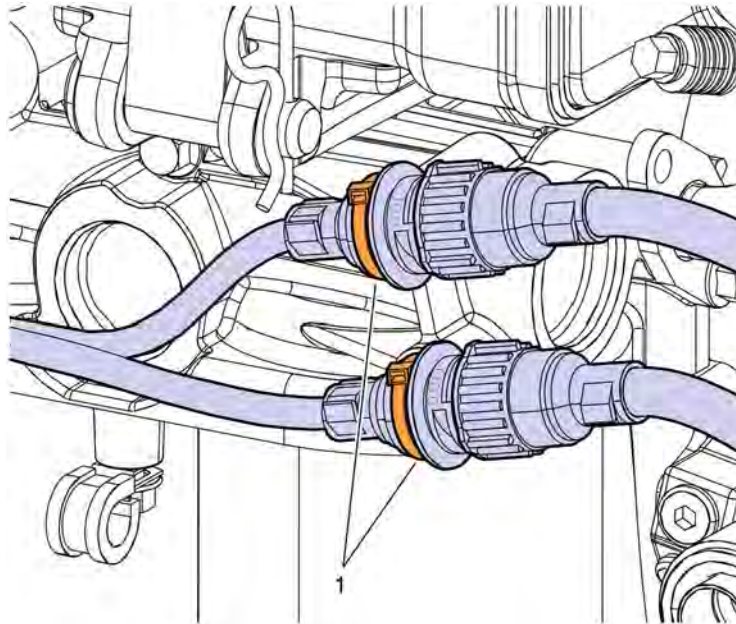

W2072567

Required Parts

Mechanical Transmission Parts List			
Item #	QTY	Part Number	Description
1	2	980881	Push-In Cable Tie

Relocation Procedures for the Mechanical Transmission

You must read and understand the precautions and guidelines in Service Information, group 20, "General Safety Practices, Engine" before performing this procedure. If you are not properly trained and certified in this procedure, ask your supervisor for training before you perform it.

NOTE: Information is subject to change without notice. Illustrations are used for reference only and can differ slightly from the actual vehicle being serviced. However, key components addressed in this information are represented as accurately as possible.

Mechanical Transmission

- 1 Apply parking brake and place shift lever in neutral.
- 2 Raise hood or raise cab.
- 3 Disconnect all cables from the negative (ground) battery terminals to prevent personal injury from electrical shock and prevent damage to electrical components.
- 4 Disconnect the engine VGT actuator and Turbine Shaft Speed (TSS) Sensor harnesses.

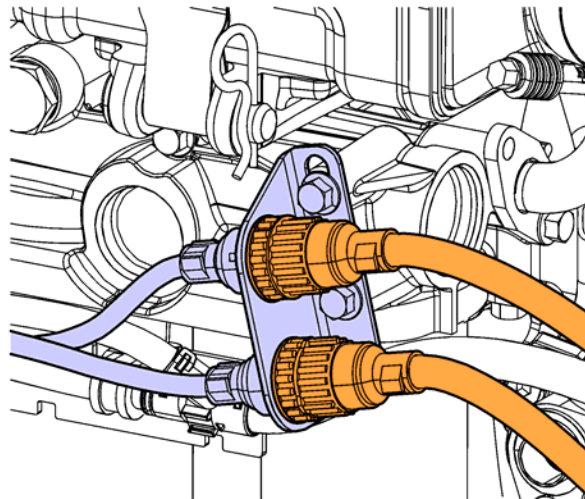

W2072330

- 5 Remove the engine VGT actuator and TSS sensor connectors from the mounting bracket.

Note: Discard the attachment ring/nut (Item 1).

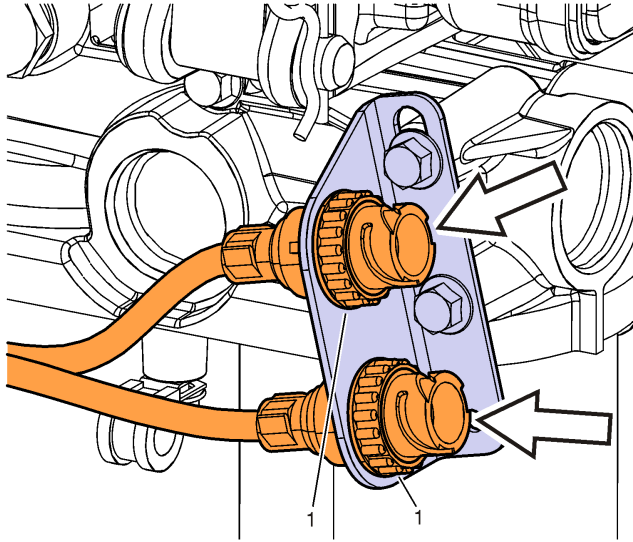

W2072331

- 6 Remove the connector mounting bracket from oil filter housing.

Note: Discard the mounting bracket.

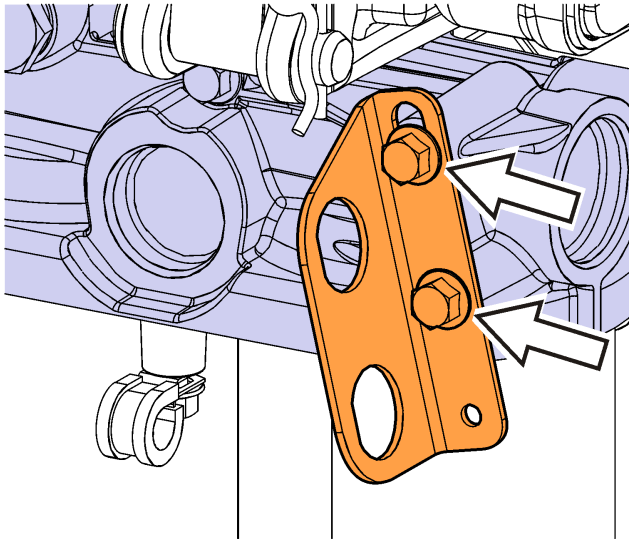

W2072332

- 7 Inspect connectors for green/brown dust on the pins or sockets.

Note: If green/brown dust is present in the areas highlighted in the figure below, clean the male and female engine VGT actuator and TSS sensor connectors with approved electrical solvent. Allow the connectors to thoroughly dry before assembly.

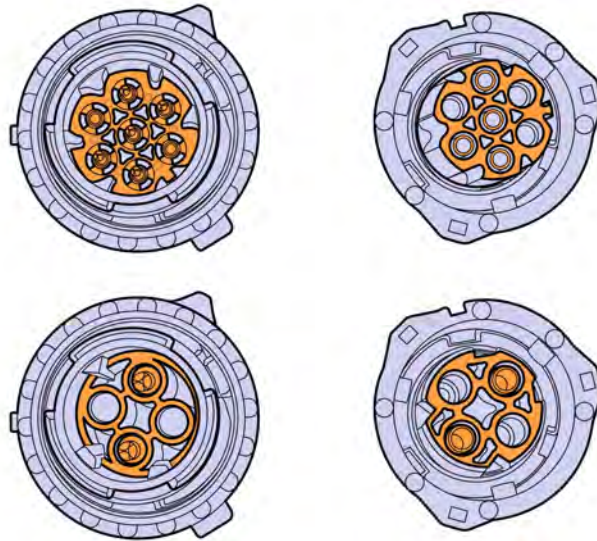

W2072325

- 8 Install the push-in cable ties (part number 980881) into the M8 threaded holes in the oil filter housing.

Note: Ensure the push-in cable tie flanges are tightly secured against the M8 threaded holes in the oil filter housing.

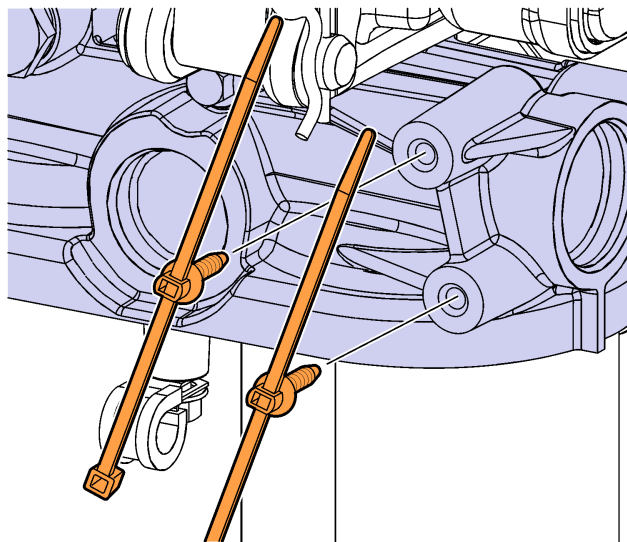

W2072333

9 Connect and lock the engine VGT actuator and TSS sensor connectors together.

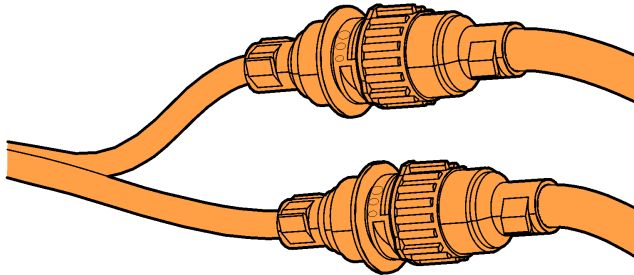

W2072334

10 Secure both connectors with the push-in cable ties.

Note: Ensure the cable tie is in the end groove between connector flange and back shell as shown in figure below.

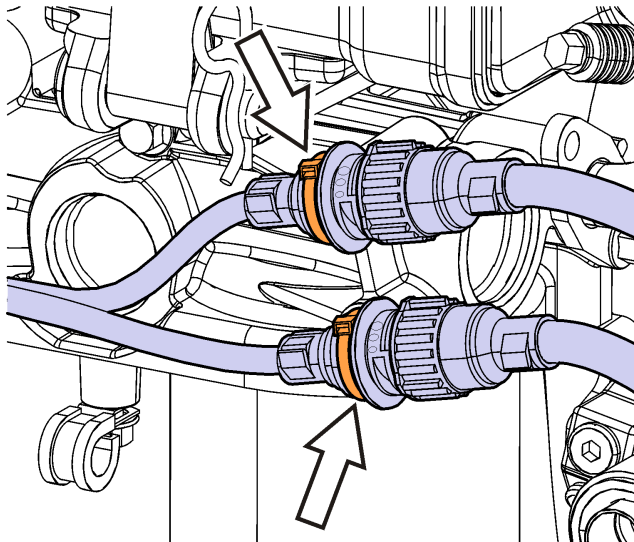

W2072335

11 Reconnect all previously removed cables to the negative (ground) battery terminals.

12 Lower hood or lower cab.

Note: To signify that the campaign has been completed, using a permanent-type marker (such as a Sharpie®) to write the campaign number (PI0781) and completion date in the spaces provided on the Campaign Completion label located inside the cab as shown in the illustration below. If a label is not already affixed inside the cab, apply a label (part No. TS897) and supply the information as required. Campaign Completion labels are available in packs of 50 and can be ordered by faxing a completed BR313 to Pacesetters Business Services at 610-264- 9465.

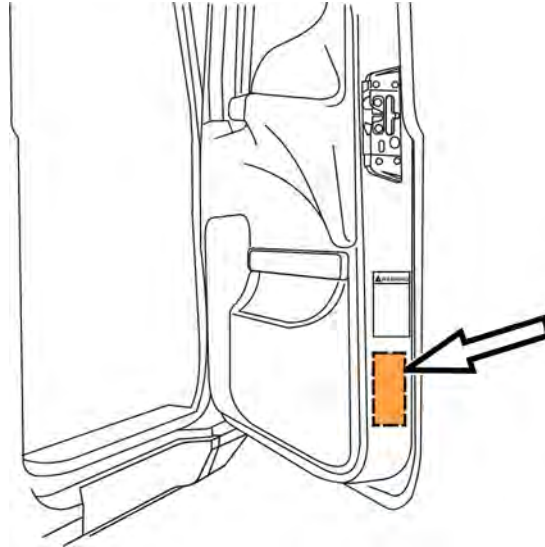

W8034103

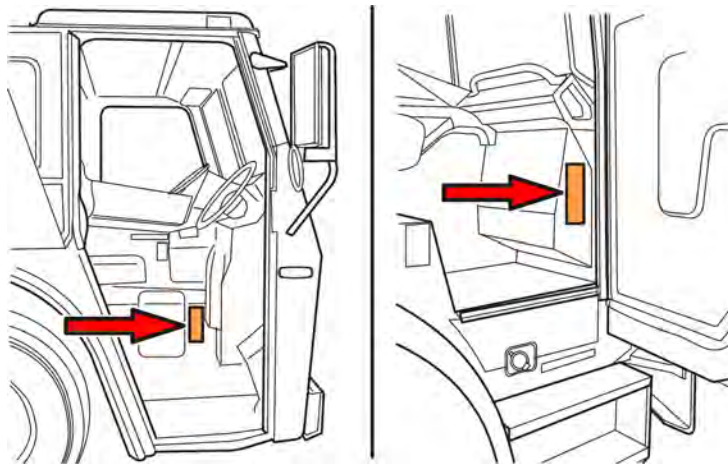

W0037061

Reimbursement

This repair is covered by an authorized Service Program. Reimbursement is obtained through the normal claim handling process.	
Claim Type (used only when uploading from the Dealer Bus. Sys.)	B
Recall Status	
Vehicle inspected, repair not required	1- Inspected OK
Vehicle repaired per instruction	2- Modified per instruction
Labor Code	
Primary Labor Code	2733J-37-96 0.3 hr.
Time to take charge and determine campaign status	101AA-0A-00 0.3 hr.
Causal Part	21551428
Authorization Number	PI0781
Expiration Date	16 MAY 13

Note: Take Charge Time is not included in the Labor Code for this operation. Take charge may be eligible but can only be used once per repair visit. If vehicle is having other warranty repairs performed, take charge should be charged to the warranty repair, otherwise take charge can be charged to this service program.