



SB-10044324-8194

Date	Group	No.	Release	Page
5.2012	255	024	03	1(8)

This Field Service Bulletin replaces bulletin, "FSB 255-023, Connector Pin Replacement", PV729-FSB255-023_M (USA53286) dated (04/2012).

Engine Variable Geometry Turbocharger (VGT) Actuator Connector Pin, Replacement
CHU, CXU, GU, TD, MRU, LEU, CMM, CMH
MP7, MP8, MP10

FSB 255-024, Engine Variable Geometry Turbocharger (VGT) Actuator Connector Pin, Replacement

(May 2012)

Severe fretting damage of the Engine Variable Geometry Turbocharger (VGT) Actuator harness may cause an unreliable signal to the engine VGT Actuator on certain MACK CHU, CXU, GU, TD, LEU and MRU trucks. An unreliable signal to the engine VGT Actuator will generate Diagnostic Trouble Codes (DTCs). If DTCs are logged and pin fretting is identified as the cause, the engine VGT Actuator connector pin and socket contacts should be replaced. Replacement of the pin and socket contacts will eliminate pin fretting and increase the reliability of the signal to the engine VGT Actuator.

Note: This bulletin also applies to MACK Trucks Australia.

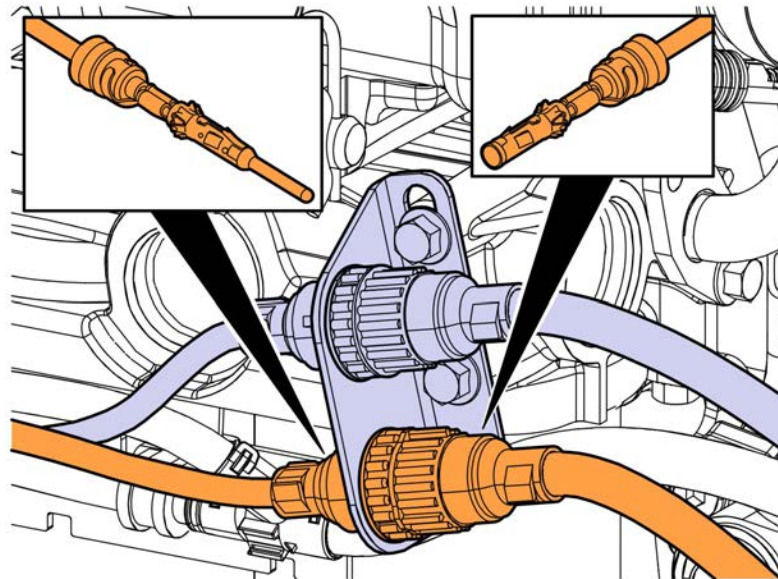

W2073530

Required Parts

Connector Pin Replacement Parts			
Item #	Part Number	Description	Crimp Jaw Position
1	984945	Pin, Eng VGT Actuator Conn	B
2	3963409	Socket, Eng VGT Actuator Conn	B
3	20734499	Wire Seal, Eng VGT Actuator Conn	N/A

Connector Pin Replacement Tools		
Item #	Part Number	Description
1	9808646	Extraction Tool, Connector Socket
2	9809774	Extraction Tool, Connector Pin
3	88890003	Crimp Pliers
4	88890004	Crimp Jaw

Procedure

You must read and understand the precautions and guidelines in Service Information, group 20, "General Safety Practices, Engine" before performing this procedure. If you are not properly trained and certified in this procedure, ask your supervisor for training before you perform it.

- 1 Raise the hood or cab.
- 2 Disconnect all cables from the negative (ground) battery terminals to prevent personal injury from electrical shock and prevent damage to electrical components.
- 3 Disconnect both harness couplers.

Note: The connectors shown are for reference only. Your actual configuration may be different, depending on truck model and components.

Note: In the event the connectors or harnesses are damaged, replace engine VGT Actuator component connector (Item 1, Figure below) with part number 984944, engine VGT Actuator engine harness connector (Item 2) with part number 3963412. Additionally, plug seal part number 970771 is required to seal any unused pin and socket locations of the connector housings.

- 4 Remove harnesses from the mounting bracket.

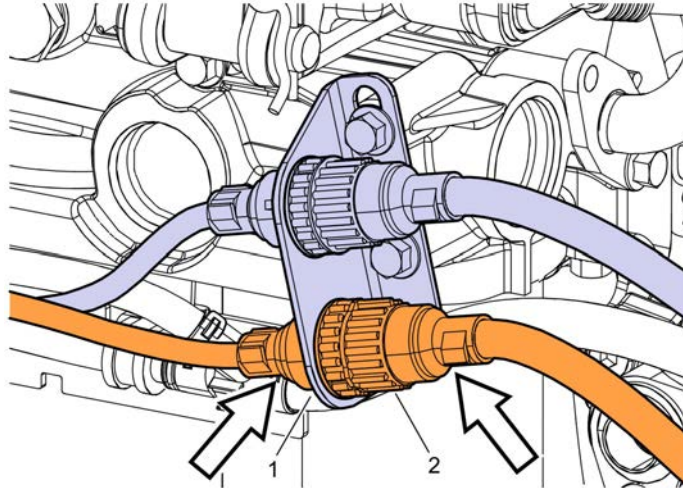

W2073531

- 5 Remove the conduit clamps from both harness sections.

Note: The engine VGT Actuator harness connector is shown for reference only.

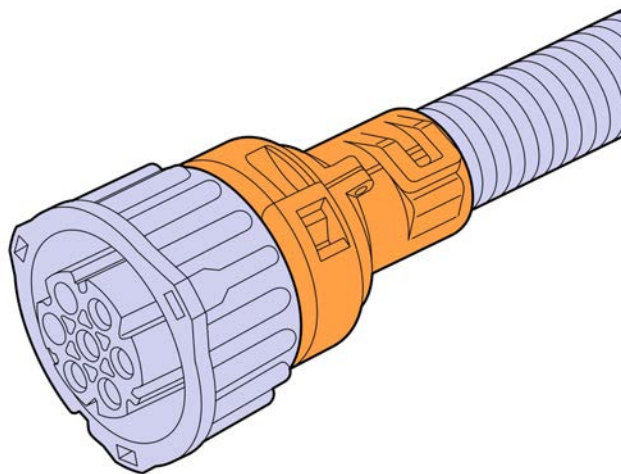

W2072543

- 6 Using extraction tool 9808646 or 9809774, remove the defective pins from the connectors.

Note: Before removing terminals, note and document pin locations for reassembly purposes.

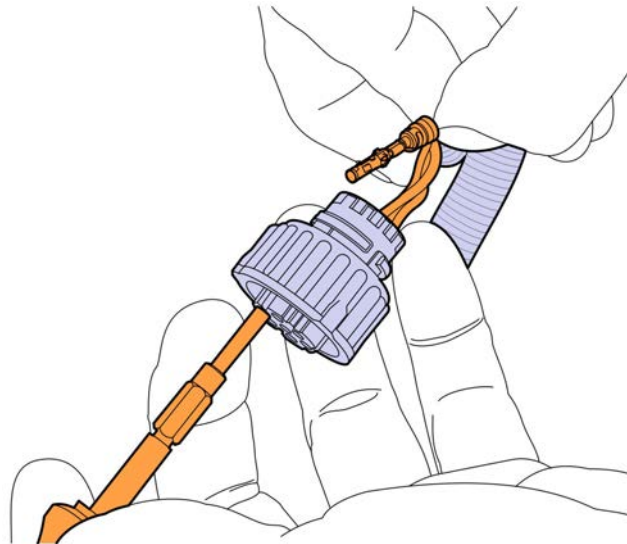

W2072544

- 7 Cut and remove old pins from the harnesses.

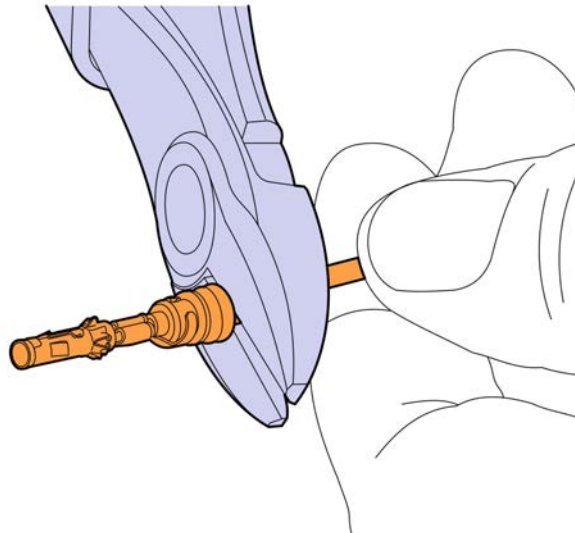

W2072545

8 Assemble the wire and the appropriate wire seal as shown in figure below.

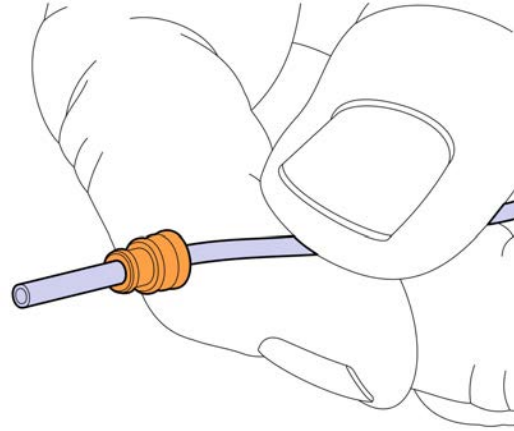

W2072546

9 Using a suitable wire stripper, strip 5 mm (0.2 in) of insulation from the end of each wire.

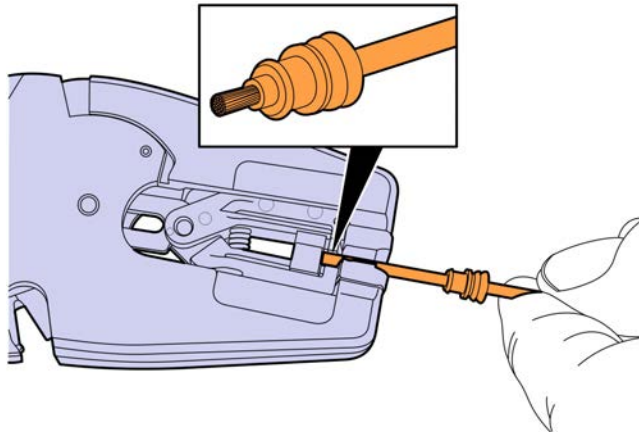

W2072547

10 Pre-assemble the appropriate pin or socket contact with stripped wire and seal.

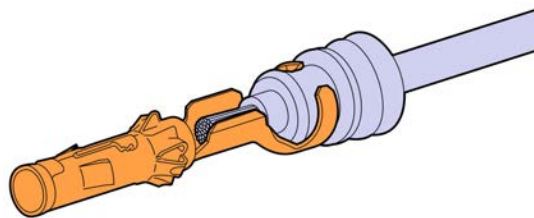

W2072548

11 Using crimp pliers 88890003 and crimp jaw 88890004, crimp the pin or socket contact.

Note: See table on page 1 for the proper crimp jaw position.

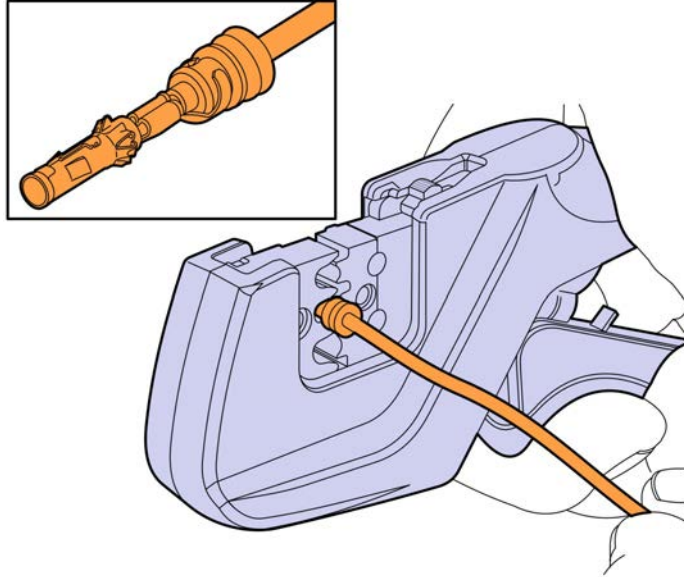

W2072549

12 Insert the crimped pin or socket in the correct position of the connector.

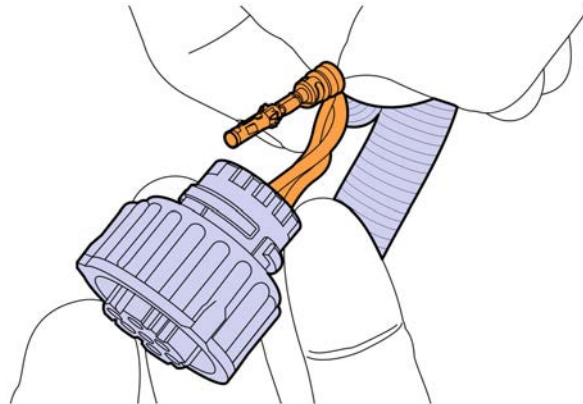

W2072550

13 Install the conduit clamps.

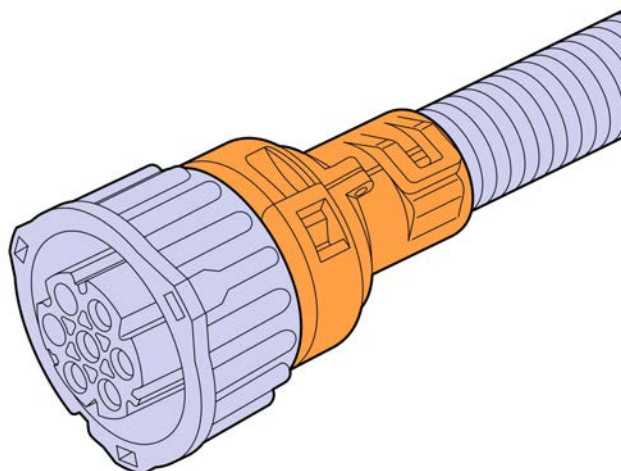

W2072543

14 Install the harnesses onto the bracket and secure.

15 Connect the harnesses.

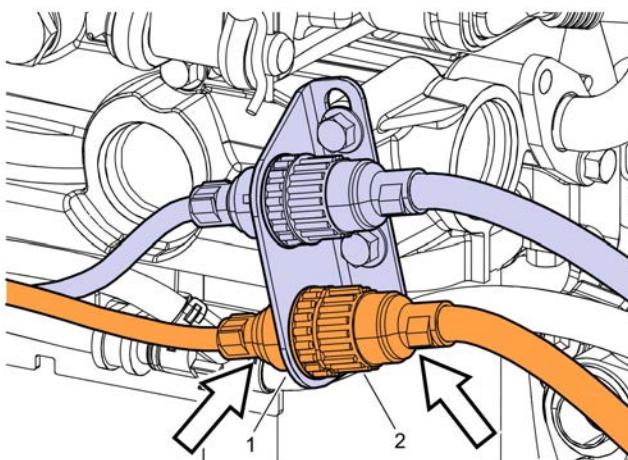

W2073531

16 Reconnect all previously removed cables to the negative (ground) battery terminals.

17 Lower hood or cab.

Reimbursement

This repair may be eligible for reimbursement if a product failure was experienced within time and mileage limits of the applicable Warranty coverage. Reimbursement is obtained via the normal claim handling process.	
Claim Type (used only when uploading from the Dealer Bus. Sys.)	W
Labor Code	
Primary Labor Code for engine VGT Actuator Pin Replacement	2732C-01-80 0.7 hrs.
Causal Part	984945

MACK Trucks North America engages in a continuous program of testing and evaluating to provide the best possible product. MACK Trucks North America, however, is not committed to, or liable for updating existing chassis.